

ASSEMBLY INSTRUCTIONS
INSTRUCTIONS DE MONTAGE
INSTRUCCIONES DE ENSAMBLAJE

5353

Mobile File Cart with Locking Top

*Mobile Dossier Charrette avec Verrouillage du
Couvercle*

Móvil Archivo Carreta con Tapa Cerradero

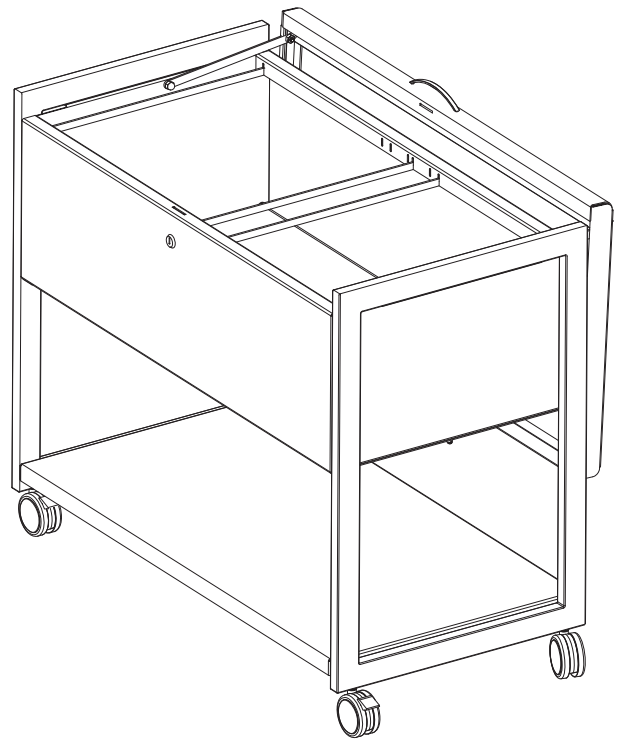
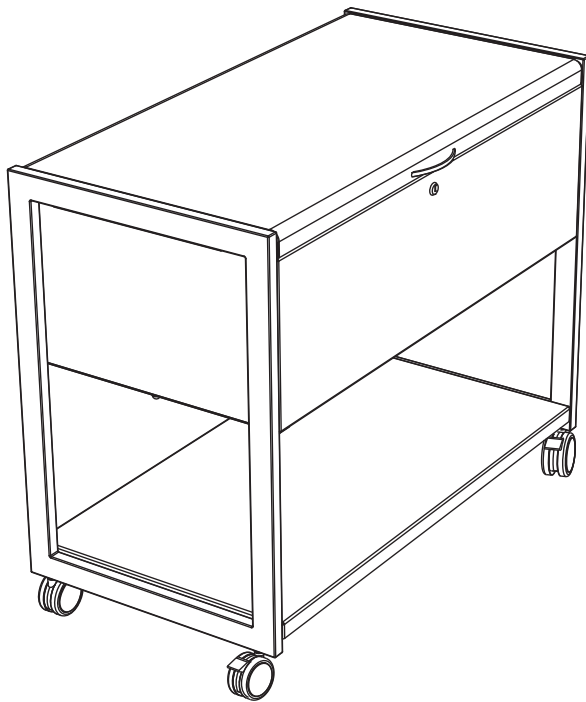

PRODUCT WARRANTY is available online at: www.safcoproducts.com

• LA GARANTIE DU PRODUIT est
disponible sur l'Internet : www.safcoproducts.com

• LA GARANTÍA DEL PRODUCTO está
disponible en la Internet: www.safcoproducts.com

For questions or concerns, please call **1-800-664-0042**
available Monday-Friday 7:30 AM to 5:00 PM (Central Time) (English-speaking operators)

Si vous avez des questions pour poser ou les préoccupations
pour exprimer, connecter **au 1-800-664-0042**
de 7H30 à 17H00 (Heure centrale) (Opérateurs de langue anglaise)

Si usted tiene preguntas o preocupaciones,
por favor llame **1-800-664-0042**
de 7:30 AM a 5:00 PM (Hora Central) (Operadores que hablan inglés)











PARTS LIST

CODE	DESCRIPTION	QTY	PART NO.
(A)	File Box, Right Side	1	100535353
(B)	File Box, Left Side	1	100535354
(C)	File Box Front	1	100535355
(D)	File Box Back	1	100535356
(E)	File Box Lid	1	100535357
(F)	Lid Support	2	100535358
(G)	Shelf	1	100535359
(H)	File Box Bottom	1	100535360
(I)	Rail Sleeves	4	100535361
(J)	File Hanger	4	100535362
(K)	Set of 2 Keys(not shown)	1	100535364
(L)	Lid sleeve	2	100535365

TOOLS REQUIRED:
Phillips Screwdriver
Caster Wrench (Included)

HARDWARE PACK

100535369

M  Screw Qty.: 12 905000098	N  Acorn Nut Qty.: 4 100535372
O  Caster Wrench Qty.: 1 100536083	P  Lid Handle Qty.: 1 100535363
R  Non-Locking Caster Qty.: 2 100536075	S  Locking Caster Qty.: 2 100536076
U  Screw Sleeve Qty.: 2 100535376	V  Flat Washer Qty.: 2 100535377
Q  Handle screw Qty.: 2 100535375	T  Medium Screw Qty.: 2 100535373
W  Small Screw Qty.: 2 100535378	











LISTE DES PIÈCES

CODE	DESCRIPTION	QUANTITÉ	N° DE PIÈCE
(A)	Dossier boîte, côté droit	1	100535353
(B)	Dossier boîte, côté gauche	1	100535354
(C)	Dossier boîte, devant	1	100535355
(D)	Dossier boîte, arrière	1	100535356
(E)	Charrette de cadre, couvercle	1	100535357
(F)	Couvercle support	2	100535358
(G)	Étagère	1	100535359
(H)	Dossier boîte, inférieur	1	100535360
(I)	Rail manchon	4	100535361
(J)	Dossier cintre	4	100535362
(K)	Ensemble de 2 clés (non montré)	1	100535364
(L)	Couvercle manchon	2	100535365

OUTILS REQUIS :
tournevis à pointe cruciforme
Boîte de fin clef (Inclus)

Paquet matériel

100535369

M  Vis Qté.:12 905000098	N  Écrou borgne Qté.:4 100535372
O  Boîte de fin clef Qty.: 1 100536083	P  Poignée Qté.: 1 100535363
R  Roulette sans frein Qté.: 2 100536075	S  Roulette avec frein Qté.: 2 100536076
U  Manchon pour vis Qty.:2 100535376	V  Rondella plate Qty.: 2 100535377
Q  Vis pour poignée Qté.: 2 100535375	T  Vis moyen Qty.: 2 100535373
W  Petit vis Qty.: 2 100535378	

LISTA DE PIEZAS











CODIGO	DESCRIPCIÓN	CANTIDAD	NO. DE PIEZA
(A)	Archivos caja, lateral derecho	1	100535353
(B)	Archivos caja, lateral izquierdo	1	100535354
(C)	Archivos caja, delante	1	100535355
(D)	Archivos caja, atrás	1	100535356
(E)	Archivos caja tapa	1	100535357
(F)	Apoyo tapa	2	100535358
(G)	Estante	1	100535359
(H)	Fondo del archivo caja	1	100535360
(I)	Reil manga	4	100535361
(J)	Percha carpeta	4	100535362
(K)	Juego de 2 llaves (no demostrado)	1	100535363
(L)	La protector para el tapa	2	100535365

HERRAMIENTAS REQUERIDAS:

Destornillador Phillips
Cuadro de llave(Incluido)

Paquete material

100535369

M  Tornillo Cant.: 12 905000098	N  Tuerca ciega Cant.: 4 100535372
O  Cuadro de llave Cant.: 1 100536083	P  Asa Cant.: 1 100535363
R  Rueda sin freno Cant.: 2 100536075	S  Rueda con freno Cant.: 2 100536076
U  Manga para tornillo Cant.:2 100535376	V  Arandela plana Cant.: 2 100535377
Q  Tornillo para asa Cant.: 2 100535375	T  Tornillo medio Cant.: 2 100535373
W  Pequeño tornillo Cant.: 2 100535378	

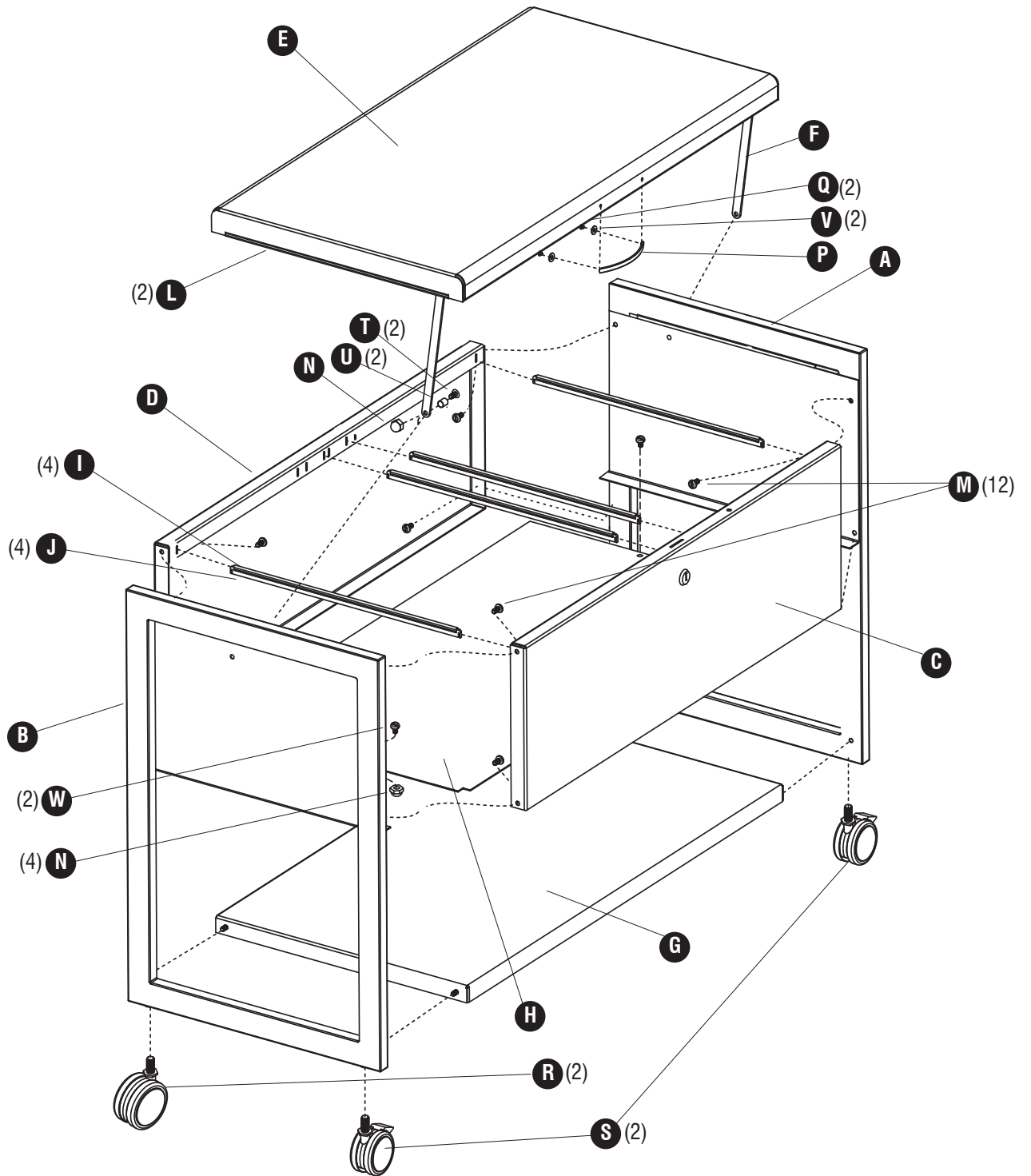

1

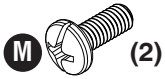

Lock.
Serrure
Cerradura

C

M (2)

A

Hole must be placed furthest from panel with lock.
Trou doit être placé le plus éloigné du panneau avec le serrure.
Agujero se deben poner más lejos de la panel que contiene el cerradura

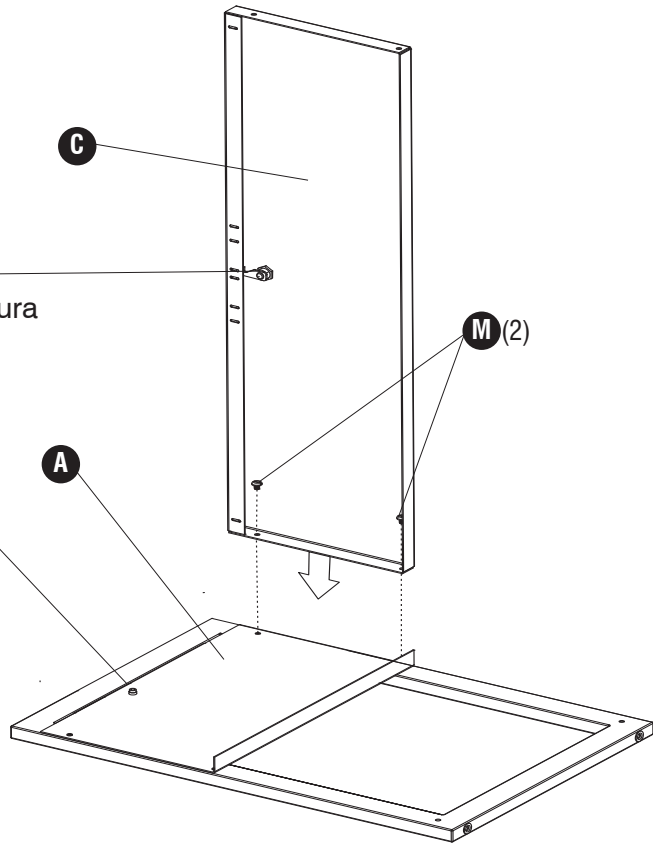

2

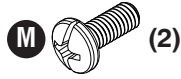

M (2)

D

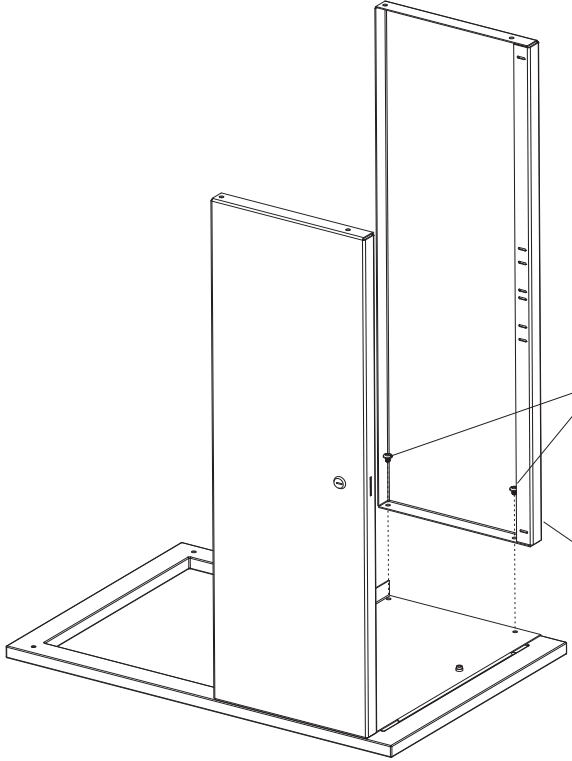

3 **M** (2)

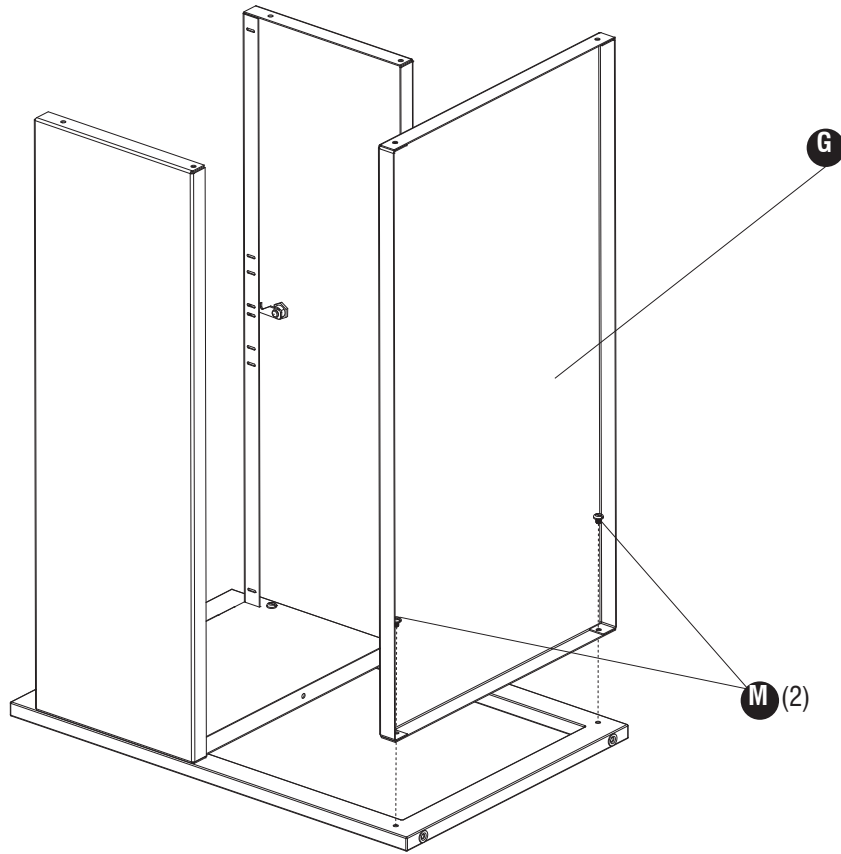

4 **R** (2) **S** (2) **M** (6)

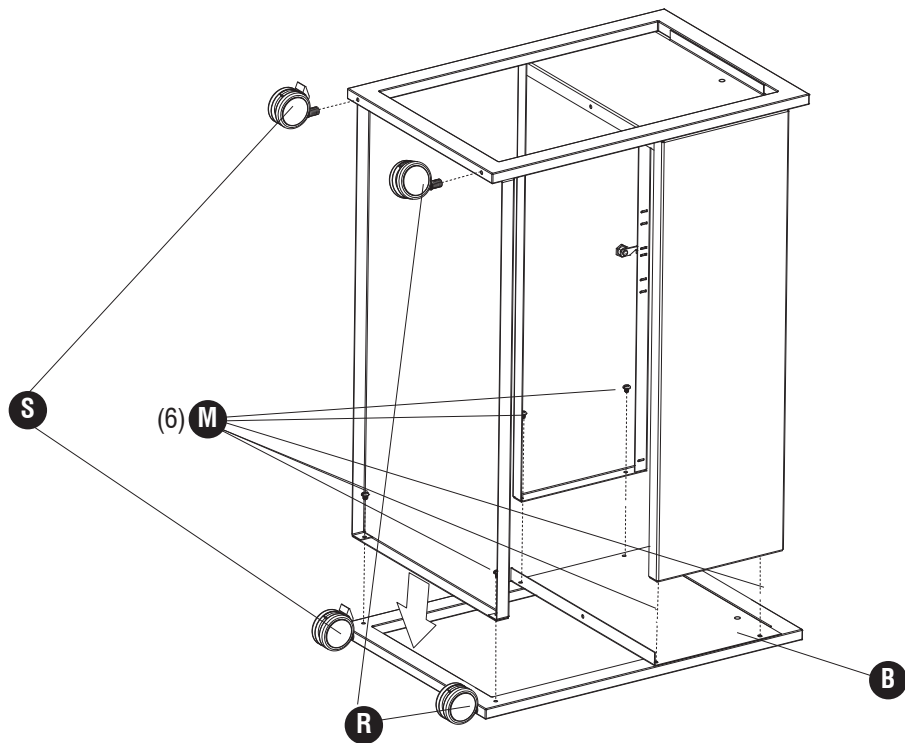

5

W



N

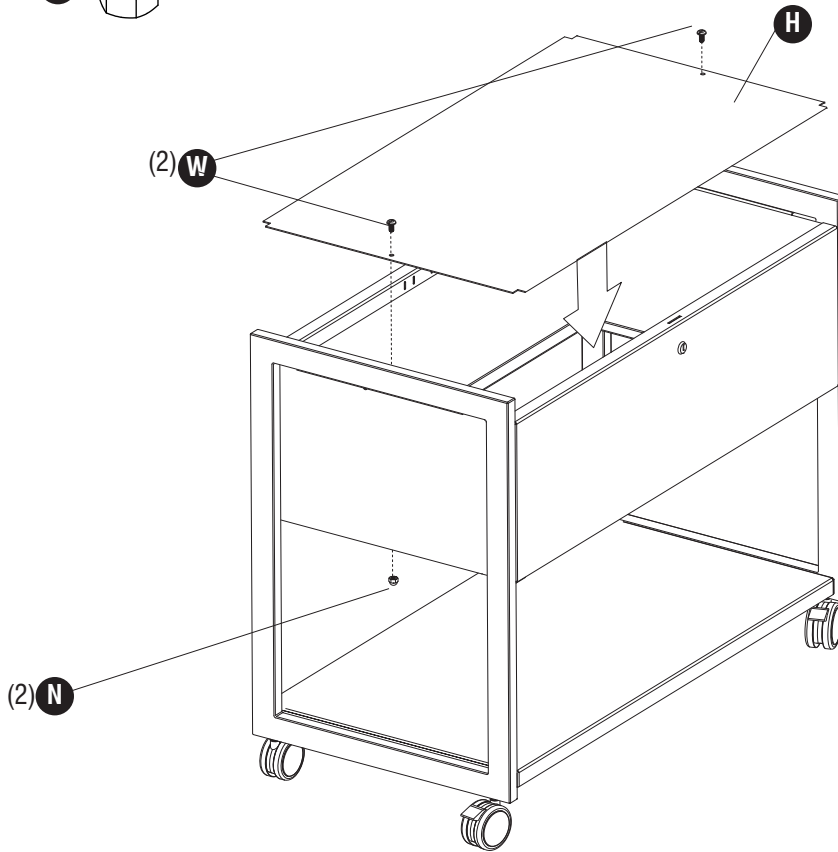
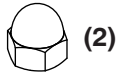

6

P



(1)

Q



V



(2)

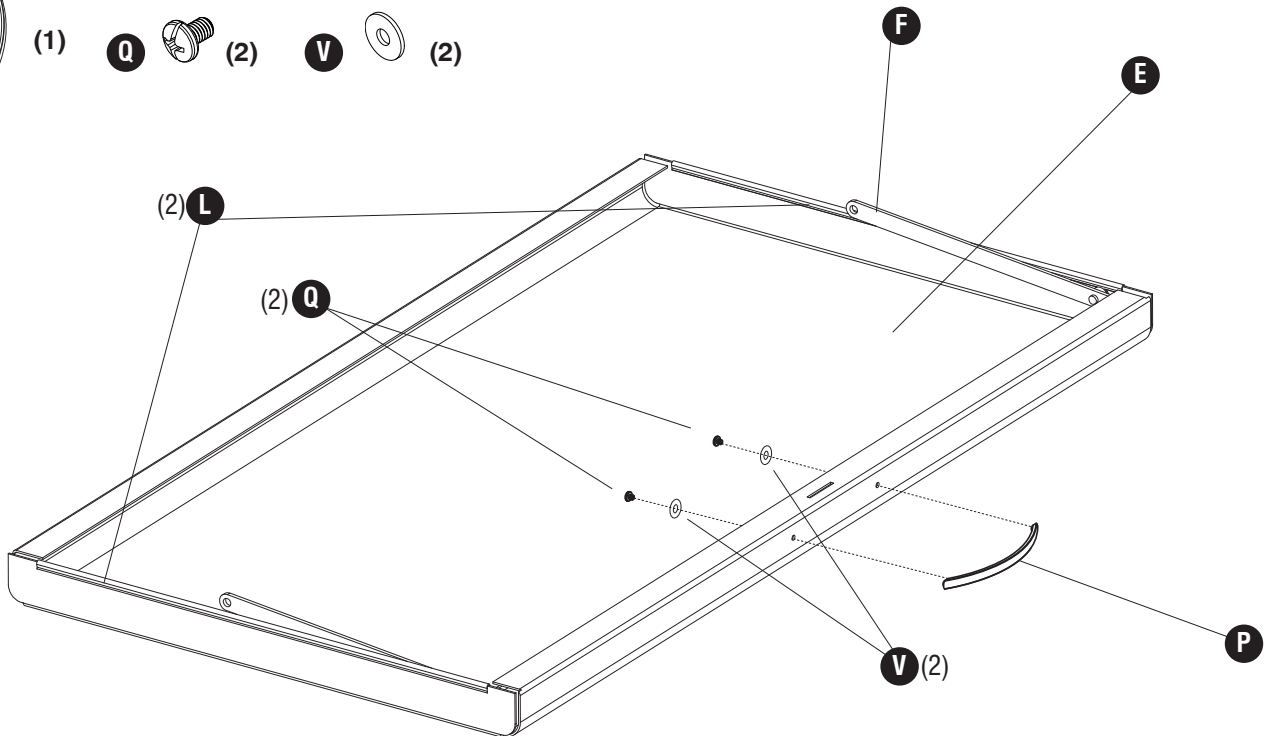

(L) May already be installed.

(L) Peut-être déjà installé.

(L) Puede que ya esté instalado.

7

T

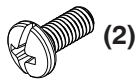

(2)

U



(2)

N



(2)

