

2193

Soar™ by Safoc Electric Desktop Sit/Stand - Dual Monitor Arm

Soar™ by Safco Bureau Électrique Sit/Stand - Bras De Moniteur Double

Soar™ by Safco Brazo Eléctrico Del Monitor Del Sit/Stand - Dual Del Escritorio

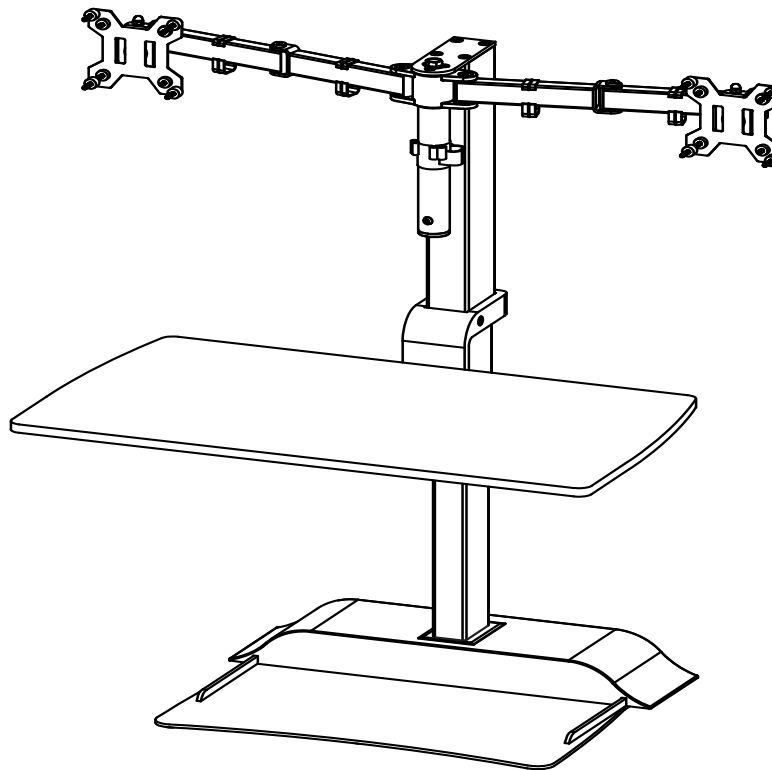

PRODUCT WARRANTY is available online at: www.safcoproducts.com

• LA GARANTIE DU PRODUIT est
disponible sur l'Internet : www.safcoproducts.com

• LA GARANTÍA DEL PRODUCTO está
disponible en la Internet: www.safcoproducts.com

For questions or concerns, please call **1-888-971-6225**
available Monday-Friday 7:30 AM to 5:00 PM (Central Time) (English-speaking operators)



Si vous avez des questions pour poser ou les préoccupations
pour exprimer, connecter au **1-888-971-6225**
de 7H30 à 17H00 (Heure centrale) (Opérateurs de langue anglaise)

Si usted tiene preguntas o preocupaciones,
por favor llame **1-888-971-6225**
de 7:30 AM a 5:00 PM (Hora Central) (Operadores que hablan inglés)

PARTS LIST / LISTE DES PIÈCES / LISTA DE PIEZAS

CODE / CODIGO	DESCRIPTION / DESCRIPTION / DESCRIPCIÓN	QTY. / QUANTITÉ / CANTIDAD	PART NO. / N° DE PIECE / NO. DE PIEZA
(A)	Column / Colonne / Columna	1	460000126
(B)	Monitor Mount Arm / Bras De Montage Du Moniteur / Brazo De Montaje Del Monitor	1	460000128
(C)	Base / Base / Base	1	470000291
(D)	Tray Mount / Support De Plateau / Soporte De Bandeja	1	470000292
(E)	Tray / Plateau / Bandeja	1	470000293
(F)	Monitor Mount Plate / Plaque De Montage Du Moniteur / Placa Del Montaje Del Monitor	2	470000306
(G)	Bumper Ø30mm / Pare-chocs Ø30mm / Parachoques Ø30mm	7	920000370
(H)	Bumper Ø15mm / Pare-chocs Ø15mm / Parachoques Ø15mm	7	920000371

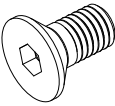





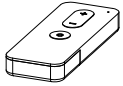





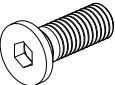
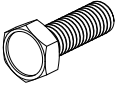

**Hardware Pack / Paquet Matériel / Paquete Material:
900000185**

I 	J 	K 	L 
Column Cap Capuchon De Colonne Casquillo De La Columna	Screw M6x12mm Vis M6x12mm Tornillo M6x12mm	Screw M4x16mm Vis M4x16mm Tornillo M4x16mm	4mm Hex Key 4mm Clé Hexagonale 4mm Llave Hexagonal
Qty. / Qté. / Cant. 1 #470000309	Qty. / Qté. / Cant. 12 #905000032	Qty. / Qté. / Cant. 5 #905000303	Qty. / Qté. / Cant. 1 #920000005

**Hardware Pack /
Paquet Matériel /
Paquete Material:
900000199**

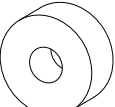
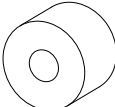
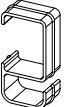
M 
Remote Control Télécommande Teledirigido
Qty. / Qté. / Cant. 1 #930000023

**Hardware Pack / Paquet Matériel / Paquete Material:
900000184**

N 	O 	J 	P 	Q 	R 
Monitor Upright Moniteur Droit Monitorear el Montante Vertical	Monitor Plate Plaque De Moniteur Placa Del Monitor	Screw M6x12mm Vis M6x12mm Tornillo M6x12mm	Screw M4x30mm Vis M4x30mm Tornillo M4x30mm	Screw M6x12mm Vis M6x12mm Tornillo M6x12mm	Screw M4x12mm Vis M4x12mm Tornillo M4x12mm
Qty. / Qté. / Cant. 1 #470000307	Qty. / Qté. / Cant. 1 #470000313	Qty. / Qté. / Cant. 4 #905000032	Qty. / Qté. / Cant. 8 #905000274	Qty. / Qté. / Cant. 1 #905000288	Qty. / Qté. / Cant. 8 #905000337
S 	T 	U 	V 	W 	X 
Screw M5x18mm Vis M5x18mm Tornillo M5x18mm	Screw M10x29mm Vis M10x29mm Tornillo M10x29mm	Acorn Nut Écrou De Gland Nuez De Bellota	Washer Rondelle Lavadora	4mm Hex Key 4mm Clé Hexagonale 4mm Llave Hexagonal	5mm Hex Key 5mm Clé Hexagonale 5mm Llave Hexagonal
Qty. / Qté. / Cant. 3 #905000338	Qty. / Qté. / Cant. 1 #905000339	Qty. / Qté. / Cant. 2 #910000022	Qty. / Qté. / Cant. 1 #915000056	Qty. / Qté. / Cant. 1 #920000005	Qty. / Qté. / Cant. 1 #920000019
Y 	Z 	AA 	BB 	CC 	DD 
Spacer 6mm Entretoise 6mm Espaciador 6mm	Spacer 10mm Entretoise 10mm Espaciador 10mm	Clip Hook Écrou De Gland Nuez De Bellota	Clip Ring Rondelle Lavadora	6mm Hex Key 6mm Clé Hexagonale 6mm Llave Hexagonal	Wrench Clé Anglaise Llave Inglesa
Qty. / Qté. / Cant. 8 #920000350	Qty. / Qté. / Cant. 8 #920000351	Qty. / Qté. / Cant. 4 #920000366	Qty. / Qté. / Cant. 1 #920000367	Qty. / Qté. / Cant. 1 #920000369	Qty. / Qté. / Cant. 1 #920000374

TOOLS REQUIRED: Phillips Screwdriver
OUTILS REQUIS : Tournevis À Pointe Cruciforme
HERRAMIENTAS REQUERIDAS: Destornillador Phillips

Make sure no obstacles are in the desk's path.
Make sure the desktop is not touching any walls.
Make sure all cords have appropriate lengths to accommodate height adjustments.

Make sure to carry the base when moving the Electric Desktop
Sit/Stand Base with Dual Monitor Arm

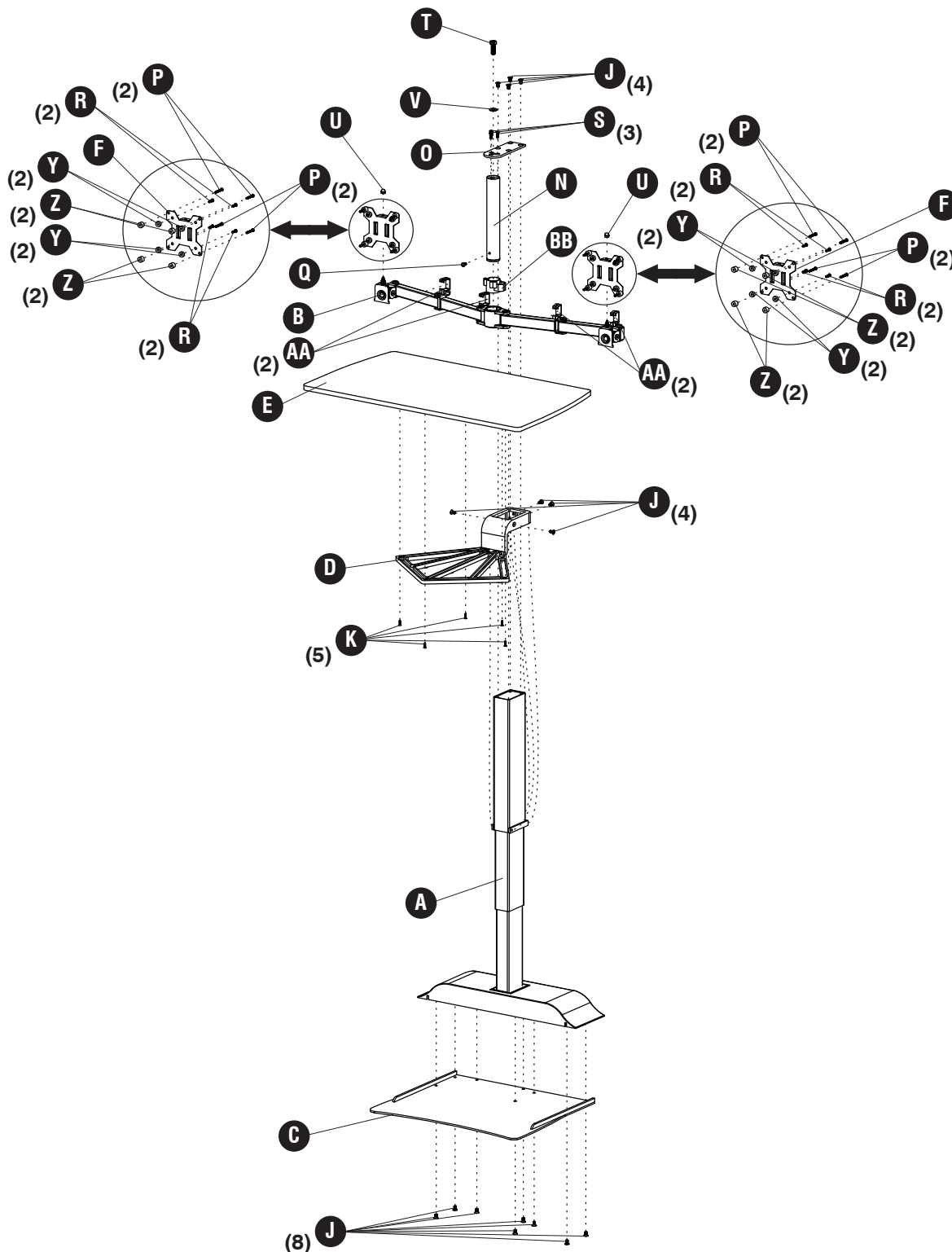

1 J (8)

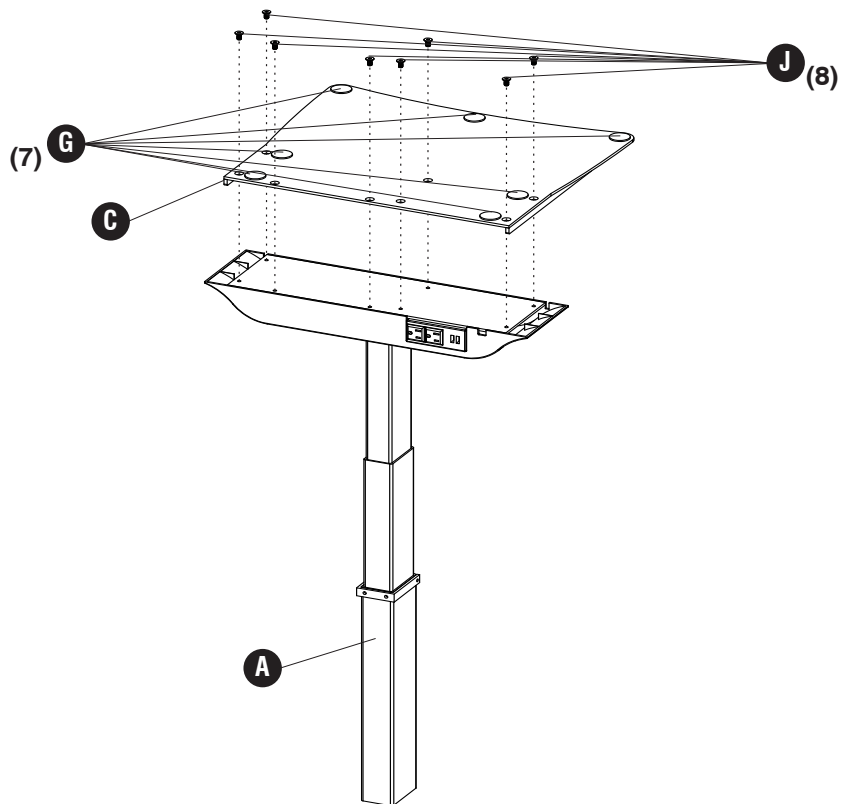

2 K (5)

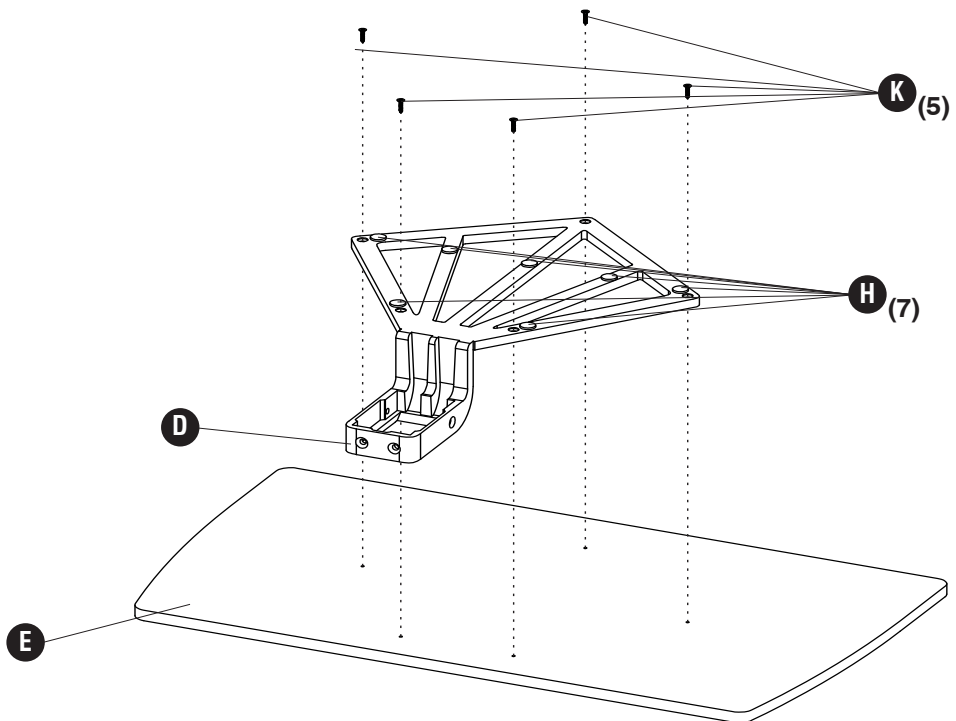
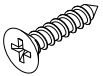

3 J (4)

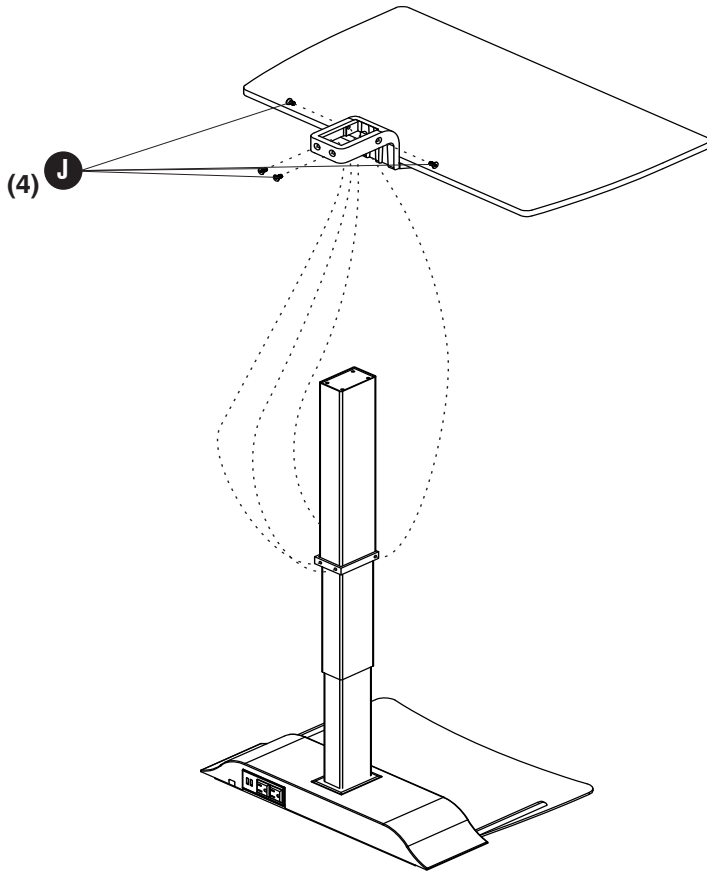
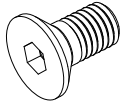

4 S (3) T (1) V (1)

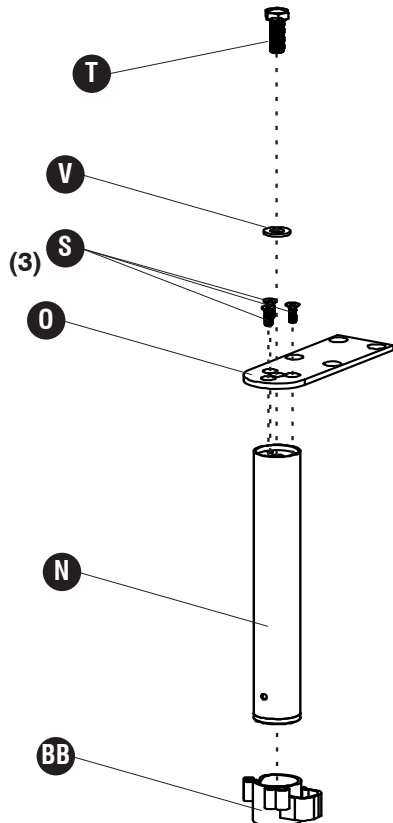
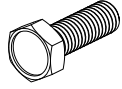
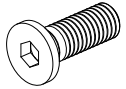

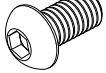
5 **Q**  (1)

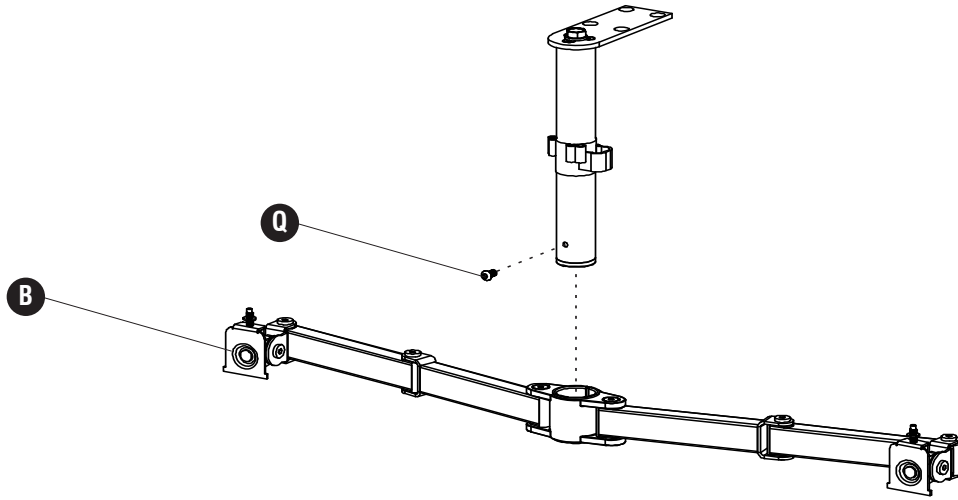

6 **J**  (4)

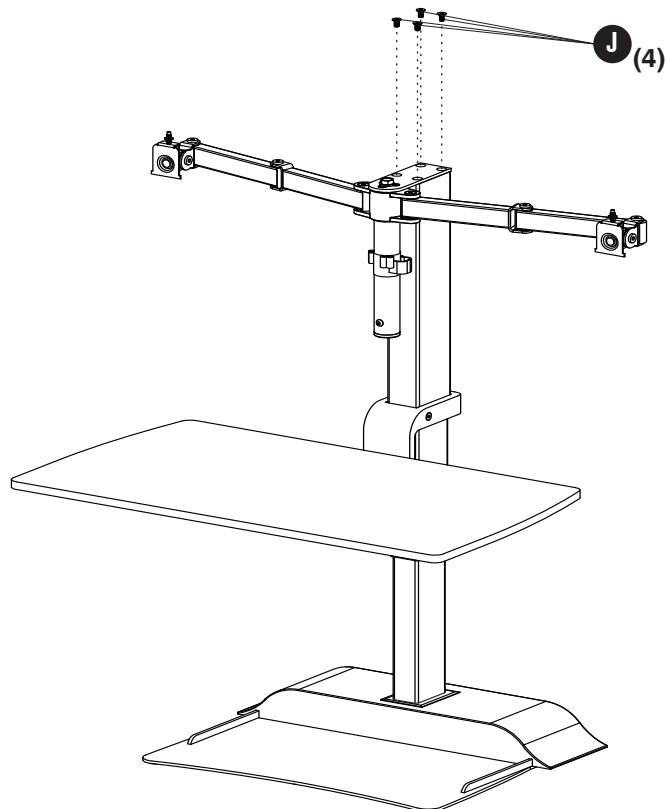

7 R

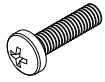

(8)

Y

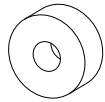

(8)

P

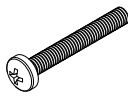

(8)

Z

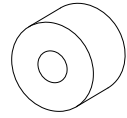

(8)

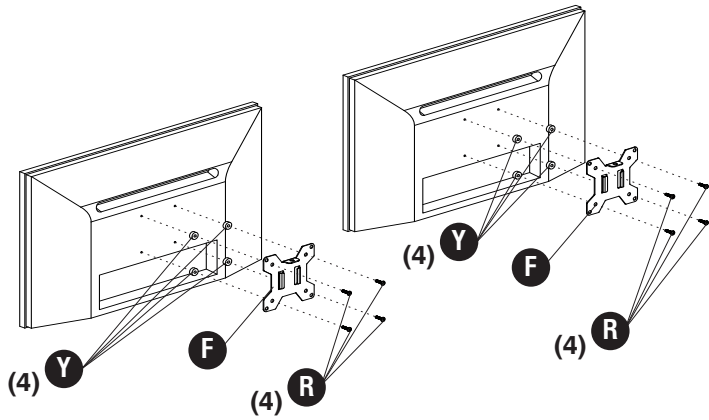

OR
OU
O

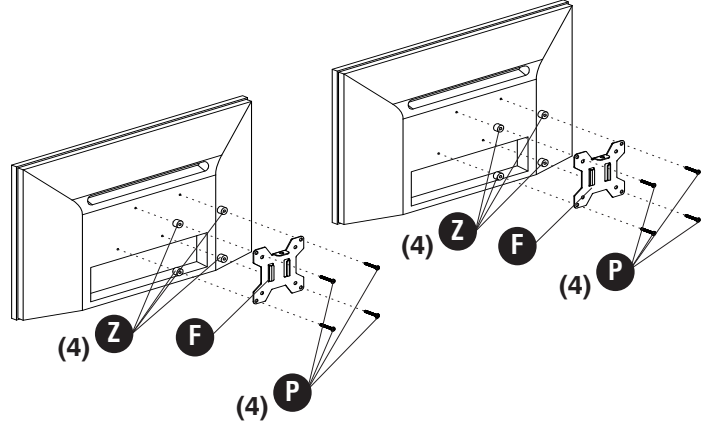

Note: Pick either hole pattern, that best fits your monitor.

Noter: Choisissez l'un ou l'autre modèle de trou, qui correspond le mieux à votre moniteur.

Note: Elija uno o el otro patrón de agujeros que mejor se adapte a su monitor.

8

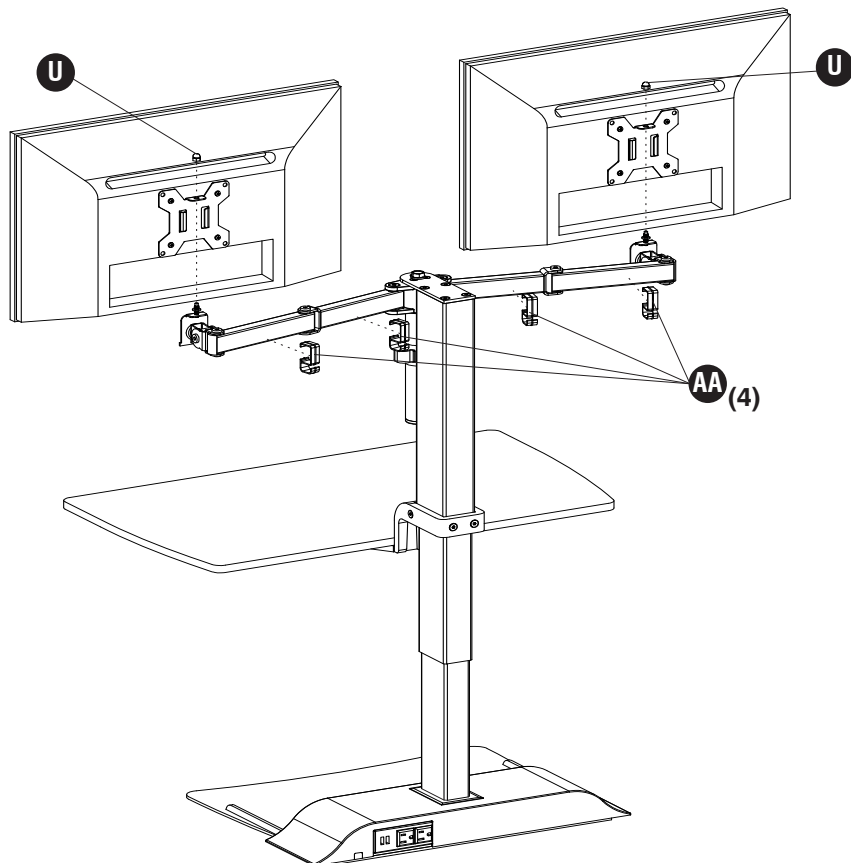

Initialization / Reset:

Press and hold “+” and “-” Button simultaneously for seven seconds, the light on the remote control will flash, then press and hold “-” button until the desk will first go to the lowest position, then rise slightly and stop, the light stops flashing. Release the “-” Button, Your desk is now ready to use. Please note that desk sometimes needs to be reset when it is not working properly. The reset process is the same as the above initialization.

Initialisation / Réinitialisation:

Appuyer simultanément sur les touches “+” et “-” pendant sept secondes, la lumière de la télécommande clignotera, puis appuyer sur la touche “-” jusqu’à ce que le Bureau se rende d’abord à la position la plus basse, puis s’élève légèrement et s’arrête, la lumière s’arrête clignotant. Relâchez le bouton “-”, votre bureau est maintenant prêt à l’emploi. S’il vous plaît noter que le Bureau doit parfois être réinitialisé quand il ne fonctionne pas correctement. Le processus de réinitialisation est le même que l’initialisation ci-dessus.

Inicialización / Restablecimiento:

Presione y sostenga el botón “+” y “-” simultáneamente por siete segundos, la luz en el teledirigido destellará, después presione y sostenga el botón “-” hasta que el escritorio primero vaya a la posición más baja, después levántese levemente y pare, la luz para intermitente. Suelte el botón “-”, su escritorio ya está listo para usar. Tenga en cuenta que el escritorio a veces tiene que ser reseteado cuando no está funcionando correctamente. El proceso de restablecimiento es el mismo que la inicialización anterior.

Program Memory Positions:

Use “+” and “-” Buttons to move desk to your desired position, then press and hold “+” and “O” Button simultaneously, the light will flash once, the first memory position is set up; press and hold “-” and “O” Button simultaneously, the light will flash once, the second memory position is set up. The Electric Desktop Sit/Stand Base with Dual Monitor Arm comes with the lowest position preset on the “O” Button, it can be overwritten by pressing the “O” Button for seven seconds, the light will flash once, then the preset memory position of the “O” Button is replaced with the current position. By quickly double clicking the button “+”, “-”, “O”, the light will flash 3 times, and your desk will go to the corresponding memory positions.

Positions de mémoire de programme:

Utilisez les boutons “+” et “-” pour déplacer le Bureau à votre position désirée, puis pressez et maintenez enfoncé “+” et “O” le bouton simultanément, la lumière clignotera une fois, la première position de mémoire est mise en place; Appuyez simultanément sur les touches “-” et “O”, la lumière clignotera une fois, la deuxième position de la mémoire sera réglée. La base de bureau électrique Sit/Stand est livré avec la position la plus basse PRESET sur le bouton “o”, il peut être écrasé en appuyant sur le bouton “o” pendant sept secondes, la lumière clignote une fois, puis la position de mémoire pré-réglée de la “o” bouton est remplacé par le courant position. En double-cliquant rapidement sur le bouton “+”, “-”, “O”, la lumière clignotera 3 fois, et votre bureau ira aux positions de mémoire correspondantes.

Posiciones de memoria de programa:

Use los botones “+” y “-” para mover el escritorio a su posición deseada, luego presione y mantenga presionado el botón “+” y “O” simultáneamente, la luz parpadeará una vez, se configurará la primera posición de memoria; mantenga presionado el botón “-” y “O” al mismo tiempo, la luz parpadeará una vez, se configurará la segunda posición de memoria. La base de asiento / soporte eléctrico de escritorio viene con la posición más baja preestablecida en el botón “O”, se puede sobrescribir presionando el botón “O” durante siete segundos, la luz parpadeará una vez, luego la posición de memoria preestablecida de “O” “El botón se reemplaza con la posición actual. Al hacer doble clic rápidamente en el botón “+”, “-”, “O”, la luz parpadeará 3 veces, y su escritorio irá al correspondiente posiciones de memoria.

If the blue light and the red light are both flashing on the base, it is a sign of malfunction, please reset the product per instruction.

Si la lumière bleue et la lumière rouge clignotent sur la base, c’est un signe de dysfonctionnement, veuillez réinitialiser le produit selon les instructions.

Si la luz azul y la luz roja parpadean en la base, esto es una señal de mal funcionamiento, reinicie el producto de acuerdo con las instrucciones.