

ASSEMBLY INSTRUCTIONS
MERCADO CORSICA HIGH-BACK CHAIR
MODEL NO. CS

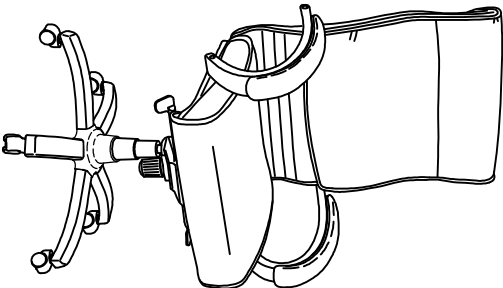







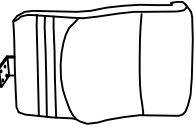

IMPORTANT!
Review ALL instructions before beginning assembly. These instructions are provided to avoid problems that may occur from improper assembly or installation. Mayline and/or its distributor are not responsible for failure resulting from improper assembly or installation of this product. Moreover, all warranties are void for failure to follow these assembly instructions.





PARTS LIST CS

When ordering components, specific color and/or size information may be required.
 Contact a Mayline Customer Service Representative. 1-800-822-8037

** Individual Items, Order by part number.
 ** Denotes Color Code*

A*		1
Part Number CM113** Back		
Reference Letter		
B*		1
Part Number CM132** Seat		
Reference Letter		
C*		1
Part Number CM151** Arms (pair)		
Reference Letter		
D*		1
Part Number CM160 Mechanism		
Reference Letter		
E*		5
Part Number CM210 Caster (5 pack)		
Reference Letter		
F*		1
Part Number CM203** Base		

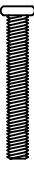
G*		1
Part Number CM470 Cylinder		
Reference Letter		
H*		1
Part Number CM192 Cylinder Cover		

Part Number CM227 * Hardware Pack		
J		6
Reference Letter		
Screw M8 x 27mm		
Reference Letter		
K		2
Reference Letter		
Screw M8 x 32mm		
Reference Letter		
L		4
Reference Letter		
Screw M8 x 55mm		
Reference Letter		
M		4
Reference Letter		
Arm Caps		
Reference Letter		
N		1
Reference Letter		
Allen Wrench		

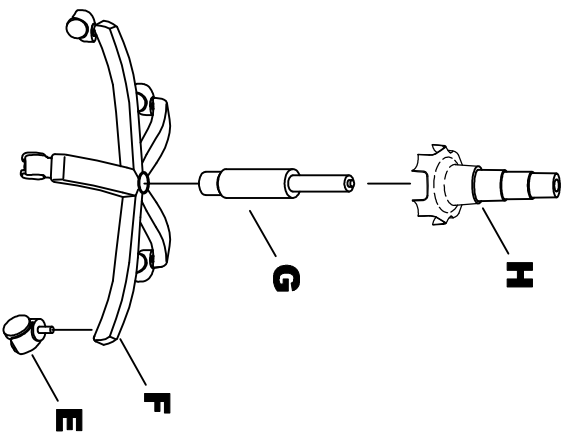

1. Place Base (F) upside down and push Casters (E) firmly into base. 5 places.
2. Turn Base right side up and insert Cylinder (G) into center hole of Base.
3. Place Cylinder Cover (H) over Cylinder.

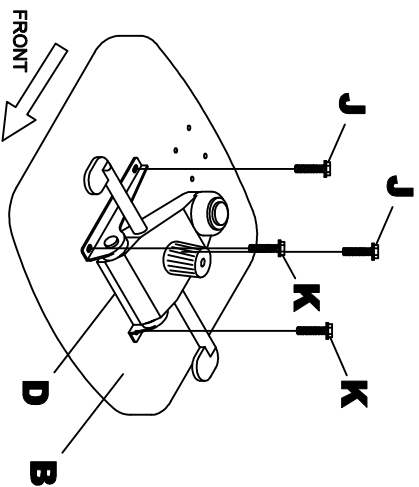

4. Assemble Mechanism (D) onto Seat (B) using Screws (K) 2 Places located in front of Seat and using Screws (J) in back of Seat.

(3)

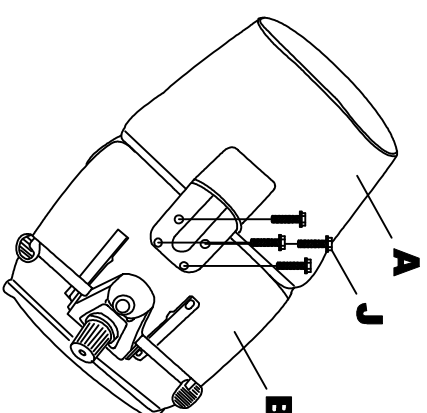

5. Assemble Back (A) onto Seat (B) using Screws (J) 4 places. DO NOT TIGHTEN SCREWS at this time. This will allow a tolerance when assembling the arms.

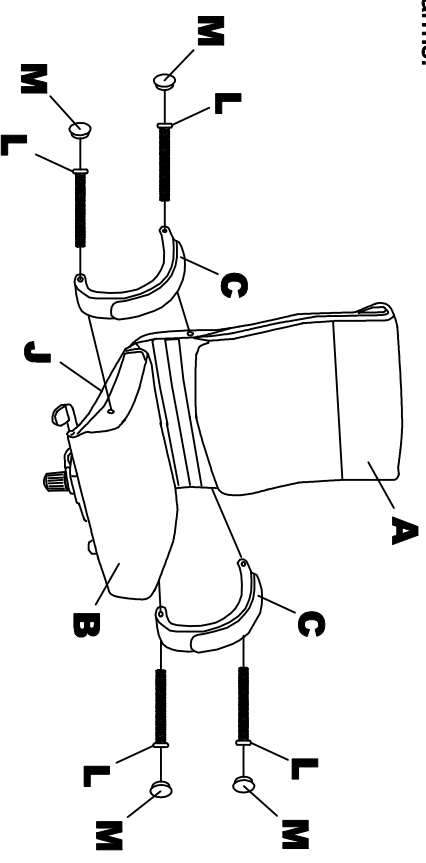

6. Assemble Arms (C) 2 places onto Back (A) & Seat (B) using Screws (L) 4 places. DO NOT TIGHTEN SCREWS at this time.
7. After both arms are installed tighten all Screws (J & L) 8 places.
8. Insert Arm Plugs (M) into Arms (C) 4 places.

(4)

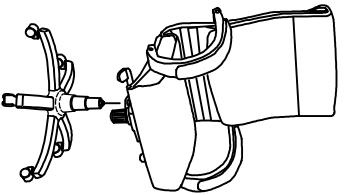

9. Carefully place chair assembly onto base assembly.

Note:

Periodically (Every 90 days) make sure screws are fully tightened.

OPERATING INSTRUCTIONS FOR DELUXE KNEE-TILT MECHANISM

1. Seat Height Adjustment.

To raise the seat, pull lever upward and raise your body up slightly to allow the chair to rise to the desired height.

To lower the seat, pull lever upward and apply weight downward on the seat.

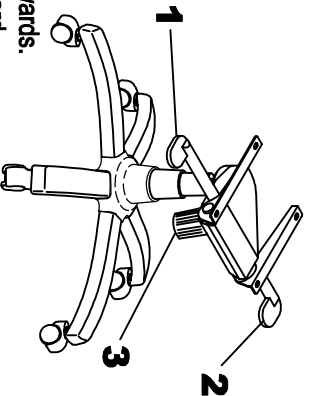

2. Seat Tilt Adjustment Lock

Pull lever upward and allow the chair to tilt backwards.

To lock to the desired position push lever downward.

To release tilt adjustment, pull lever upward, apply weight onto the back cushion and then lean forward.

3. Tilt Tension Control Knob.

Turn knob clockwise to increase tilt tension.

Turn knob counter-clockwise to decrease tilt tension.