

WORK SURFACE ATTACHMENT INSTRUCTIONS

VariTask™ LT

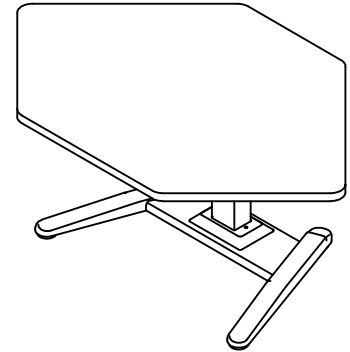

NOTE: Hardware for attaching Top, Control Box, and Switch Control is included with the Base.

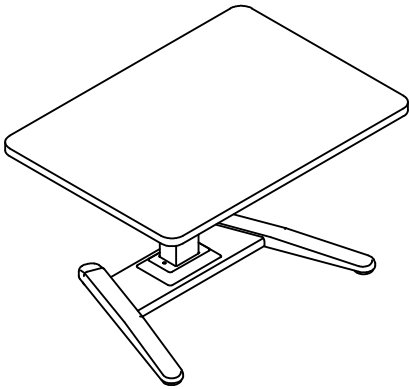
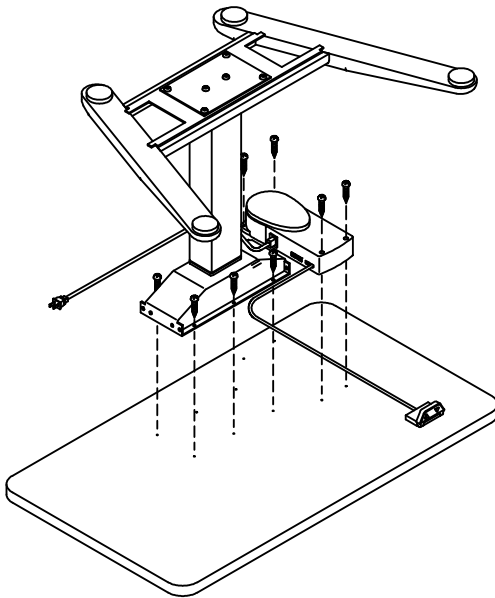

1. Align the holes in the Top with the holes in the Actuator Plate and secure in place with six #10 x 3/4 Screws (E5).

2. Align the holes in the Control Box with the holes in the underside of the Top and attach it with four #10 x 3/4 Screws (E5).

3. Place the Switch in a comfortable and accessible location on the underside of the Top and attach it with two #8 x 3/4 Screws (E7).

4. Route the column cables and the switch cable away from moving components and secure them in place with Cable Clamps (E1 & E2) and Screws (E5).



DataCENTER WORK SURFACE ATTACHMENT INSTRUCTIONS

VariTask™ LT

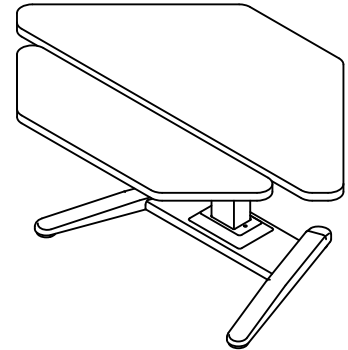
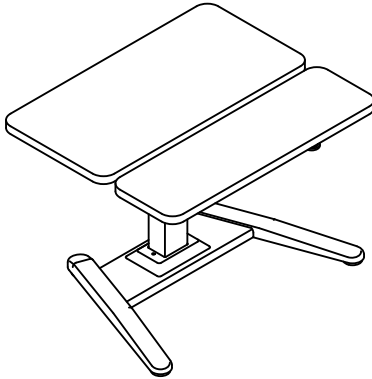

NOTE: Hardware for attaching DataCENTER is included with the DataCENTER

1. Place both Top and Keyboard face down onto a clean/protected surface.

2. Align the holes in the DataCenter with the holes in the Top and Keyboard. Secure the DataCenter with #10 x 3/4 Screws supplied with the mechanism.

NOTE: Hardware for attaching Top, Control Box, and Switch Control is included with the Base.

3. Pass the switch cord between the top and the DataCenter cross tube.

4. Align the holes in the Top with the holes in the Actuator Plate and secure in place with six #10 x 3/4 Screws (E5).

5. Align the holes in the Control Box with the holes in the underside of the Top and attach it with four #10 x 3/4 Screws (E5).

6. Place the Switch in a comfortable and accessible location on the underside of the Top and attach it with two #8 x 3/4 Screws (E7).

7. Route the column cables and the switch cable away from moving components and secure them in place with Cable Clamps (E1 & E2) and Screws (E5).

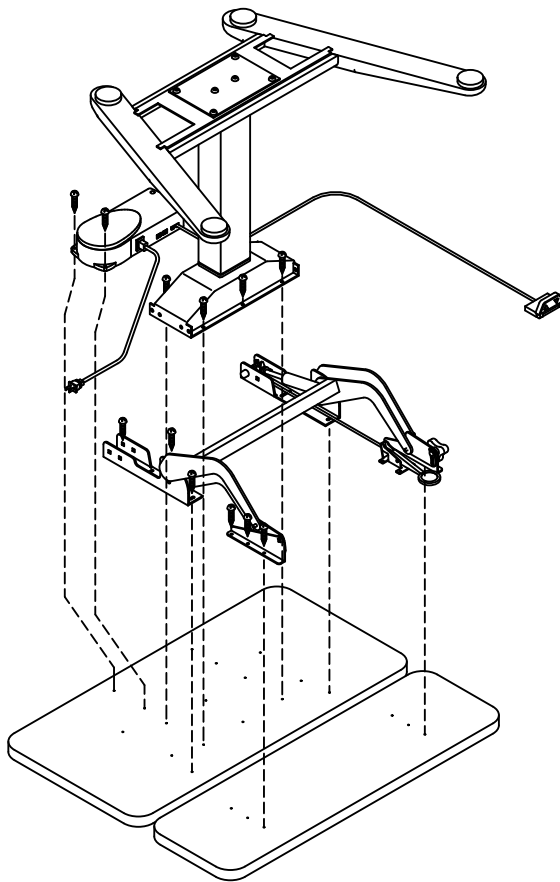

DataCENTER SERVICE PARTS LIST

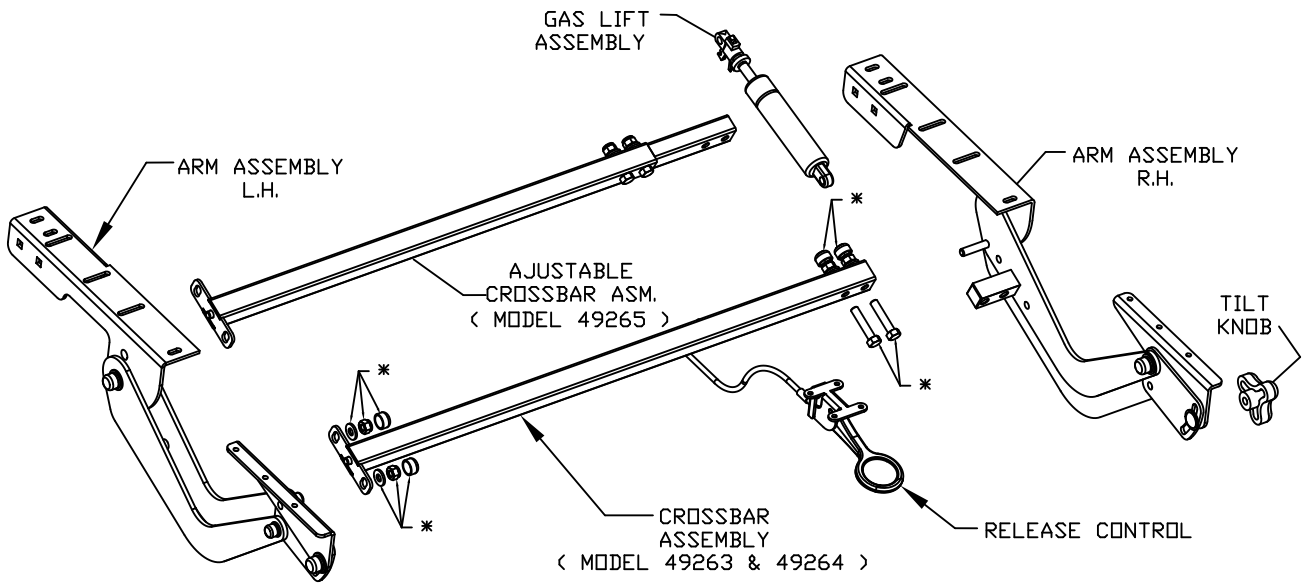

NOTE:
* ITEMS INCLUDED IN
HARDWARE BAG.

SERVICE PARTS FOR FOLLOWING PRODUCTS LISTED AS SHOWN:	ARM ASSEMBLY R.H.	GAS LIFT ASSEMBLY	RELEASE CONTROL	CROSSBAR ASSEMBLY	ARM ASSEMBLY L.H.	TILT KNOB	HARDWARE BAG ASSEMBLY	CABLE TIE KIT	ADJ. CROSSBAR HARDWARE KIT
PRODUCT NO. 49263	49266	49268	49269	49270	49267	49273	49274	49275	N/A
PRODUCT NO. 49264	49266	49268	49269	49271	49267	49273	49274	49275	N/A
PRODUCT NO. 49265	49266	49268	49269	49272	49267	49273	49274	49275	49276