

an LDI Company

New Hope, MN 55428
www.safcoproducts.com

ASSEMBLY INSTRUCTIONS

INSTRUCTIONS DE MONTAGE • INSTRUCCIONES DE ENSAMBLAJE

TOOLS REQUIRED: Phillips Screwdriver

PRODUCT WARRANTY REGISTRATION is available online at: www.safcoproducts.com

- **OUTILS REQUIS :** Tournevis cruciform
- **LA GARANTIE DU PRODUIT** est

disponible sur l'Internet : www.safcoproducts.com

- **HERRAMIENTAS REQUERIDAS:** Destornillador Phillips
- **LA GARANTÍA DEL PRODUCTO** está

disponible en la Internet: www.safcoproducts.com

PARTS LIST / LISTE DES PIÈCES / LISTA DE PIEZAS

CODE / CODIGO	DESCRIPTION / DESCRIPTION / DESCRIPCIÓN	QTY. / QUANTITÉ / CANTIDAD	PART NO. / N° DE PIECE / NO. DE PIEZA
(A)	2" Shelf / Tablette 5 cm (2 po) / Repisa de 5 cm (2")	2	7250-17\$
(B)	5/8" Shelf / Tablette 1,5 cm (5/8 po) / Repisa de 1.5 cm (5/8")	5	9254-19\$
(C)	Outer Side Panel / Panneau latéral extérieur / Panel exterior lateral	2	7260-01\$
(D)	Inner Side Panel / Panneau latéral intérieur / Panel interior lateral	2	9264-01\$
(E)	Fiber Back Panel / Panneau de fond de fibres / Panel posterior de fibra	1	7221-09
(F)	Divider / Séparateur / Separador	2	9223-25\$
(G)	Plastic Button / Bouton en plastique / Botón de plástico	4	9632
(H)	Screw / Vis / Tornillo	8	9226

HARDWARE PACK / PAQUET MATÉRIEL / PAQUETE MATERIAL 9254HW

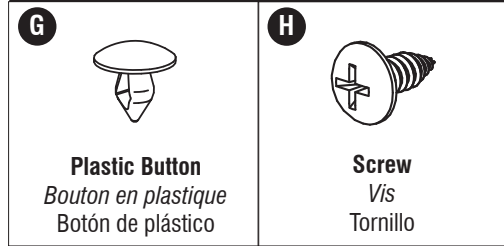

§ **Note:** When corresponding about parts, be sure to state color:

Gray (GR).

§ **Noter :** Quand correspondre au sujet de parties, soyez sûr d'affirmer la couleur:

Gris (GR).

§ **Note:** Al corresponder sobre las piezas, esté seguro declarar el color:

Gris (GR).

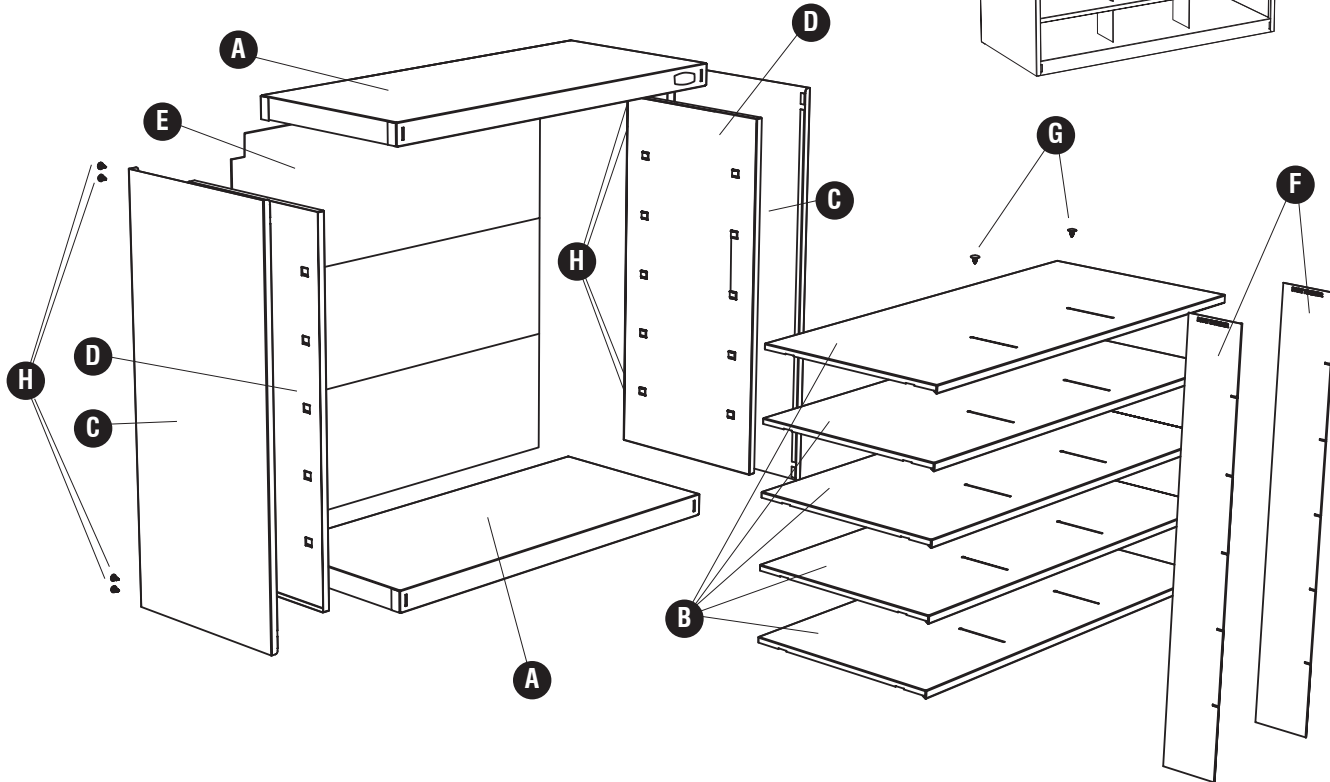

L'Assistance téléphonique à la clientèle Safco au 1-800-664-0042
de 7H30 à 17H00 (Heure centrale) (Opérateurs de langue anglaise)

Línea directa para el cliente de Safco 1-800-664-0042
de 7:30 AM a 5:00 PM (Hora Central) (Operadores que hablan inglés)

1 **H**  (4)

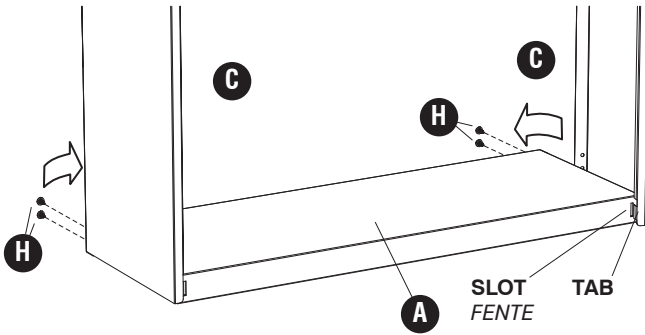

2 **NOTCH**
ENTAILLE
HENDIDURA

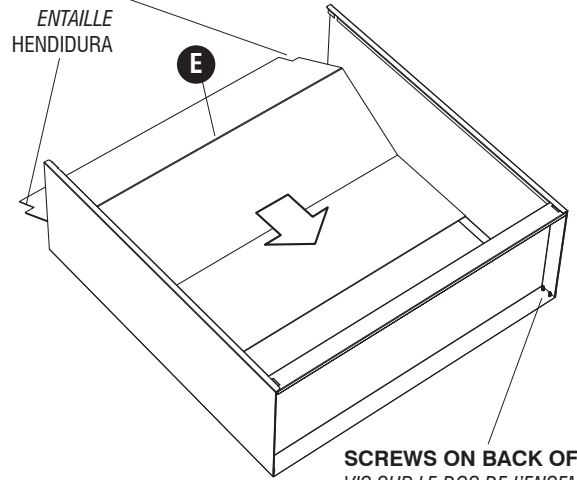

SCREWS ON BACK OF UNIT
VIS SUR LE DOS DE L'ENSEMBLE
TORNILLOS EN LA PARTE DE
ATRÁS DE LA UNIDAD

TOP OF UNIT
DESSUS DE L'ENSEMBLE
EXTREMO SUPERIOR DE LA UNIDAD

D

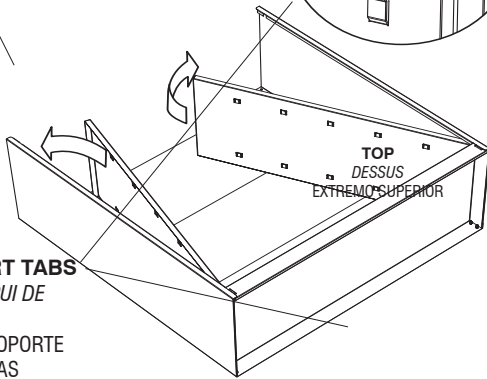
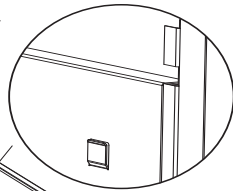

SHELF SUPPORT TABS
TAQUETS D'APPUI DE
TABLETTE
LENGÜETAS DE SOPORTE
PARA REPISAS

4

SHELF NOTCH
ENTAILLE DE TABLETTE
HENDIDURA DE LA REPISA

FRONT OF UNIT
DEVANT DE L'ENSEMBLE
FRENTE DE LA UNIDAD

B

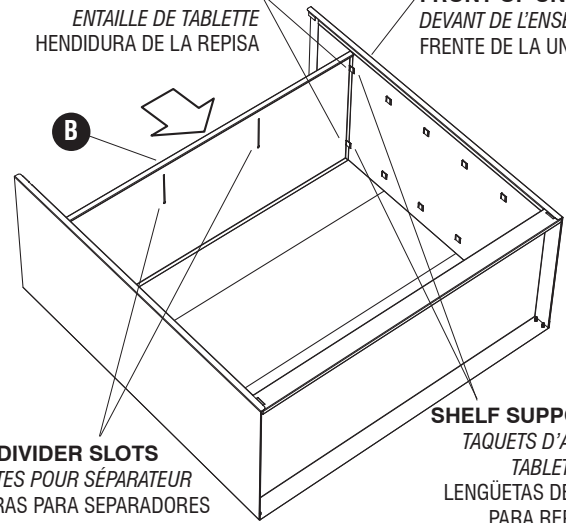

DIVIDER SLOTS
FENTES POUR SÉPARATEUR
RANURAS PARA SEPARADORES

SHELF SUPPORT TABS
TAQUETS D'APPUI DE
TABLETTE
LENGÜETAS DE SOPORTE
PARA REPISAS

5

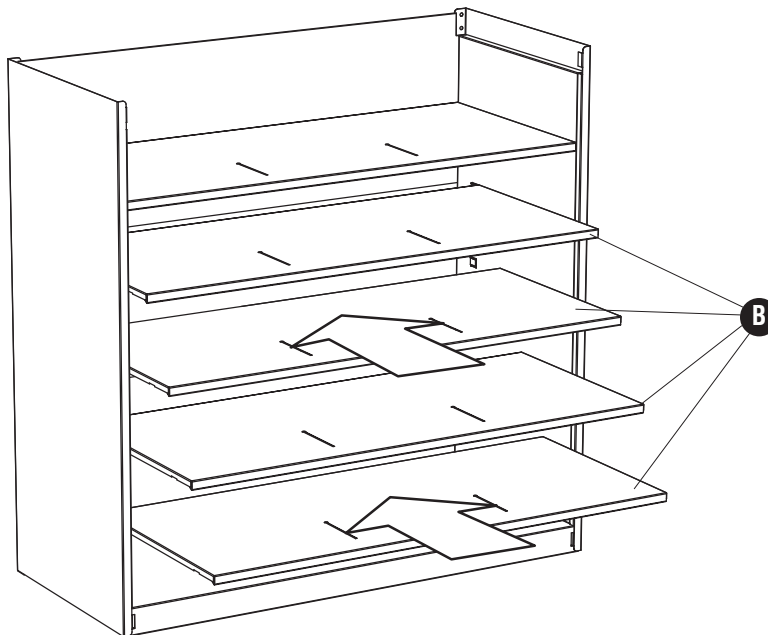

6 IMPORTANT: STAMPED PART NUMBER GOES AT TOP OF UNIT
 ATTENTION : S'ASSURER QUE LE NUMÉRO DE PIÈCE IMPRIMÉ SE TROUVE VERS LE HAUT DE L'ENSEMBLE.
 IMPORTANTE: EL NÚMERO DE PIEZA DEBE QUEDAR EN LA PARTE SUPERIOR DE LA UNIDAD.

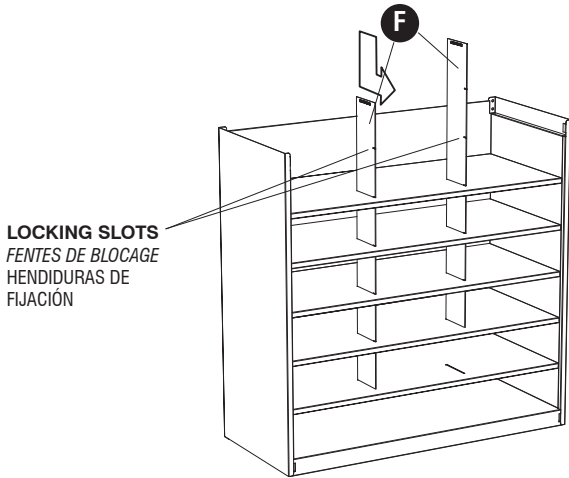

7 G  (4)

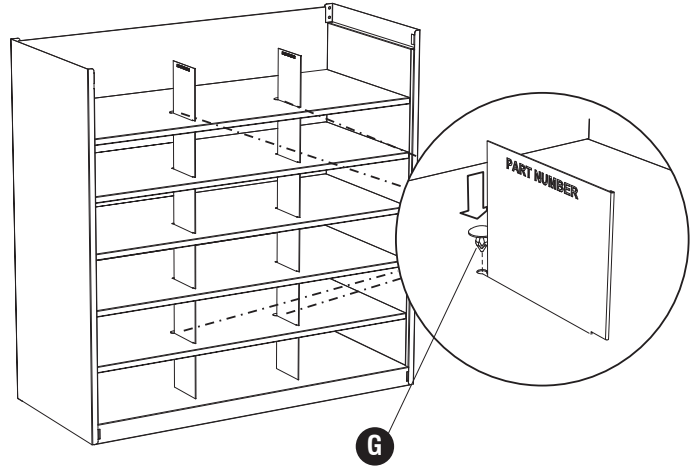

8 IMPORTANT: BACK PANEL GOES INSIDE SHELF
 ATTENTION : S'ASSURER QUE LE PANNEAU DE FOND SE TROUVE À L'INTÉRIEUR DE L'TABLETTE.
 IMPORTANTE: EL PANEL POSTERIOR DEBE QUEDAR EN EL INTERIOR DE LA REPISA.

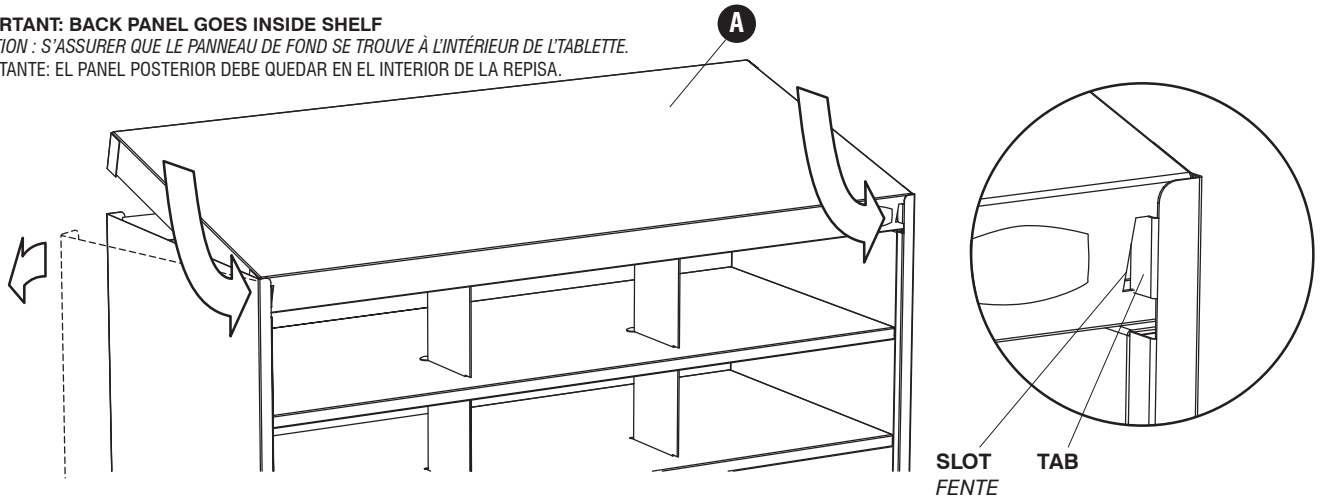

9 H  (4)

