

ASSEMBLY INSTRUCTIONS
INSTRUCTIONS DE MONTAGE
INSTRUCCIONES DE ENSAMBLAJE

Steel Flat Files
4986
Classeurs Horizontaux en acier
Archivadores horizontales de acero

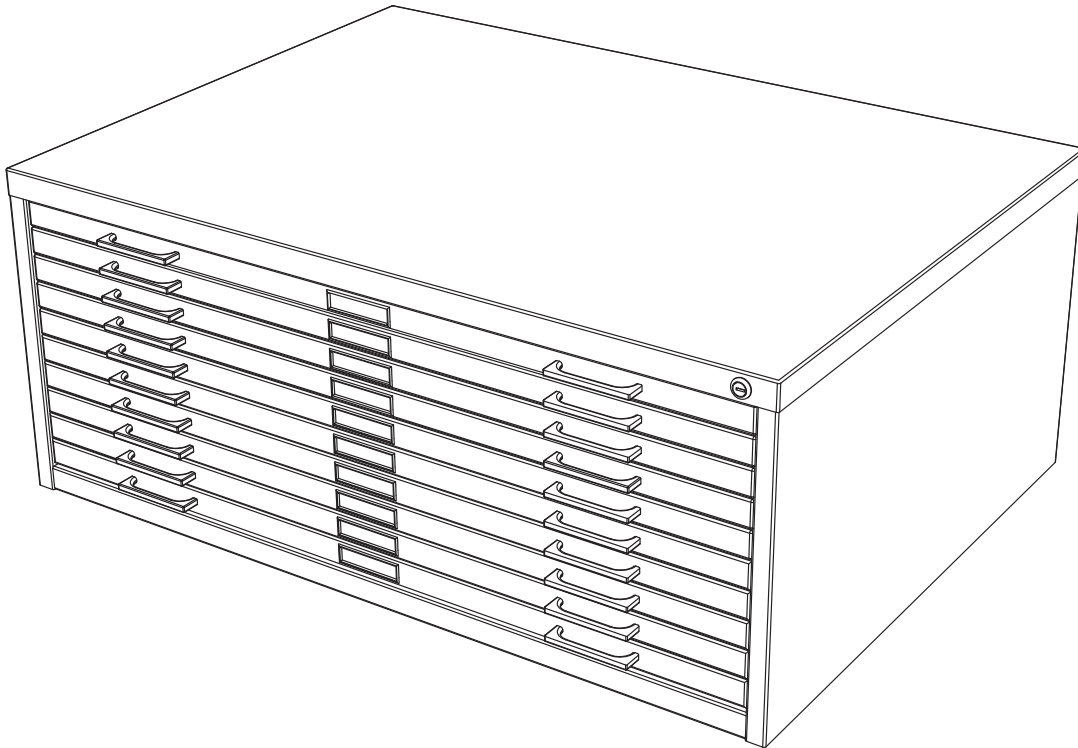

PRODUCT WARRANTY REGISTRATION is available online at: www.safcoproducts.com

• LA GARANTIE DU PRODUIT est
disponible sur l'Internet : www.safcoproducts.com

• LA GARANTÍA DEL PRODUCTO está
disponible en la Internet: www.safcoproducts.com





For questions or concerns, please call **1-800-664-0042**
available Monday-Friday 7:30 AM to 5:00 PM (Central Time) (English-speaking operators)

Si vous avez des questions pour poser ou les préoccupations
pour exprimer, connecter **au 1-800-664-0042**
de 7H30 à 17H00 (Heure centrale) (Opérateurs de langue anglaise)

Si usted tiene preguntas o preocupaciones,
por favor llame **1-800-664-0042**
de 7:30 AM a 5:00 PM (Hora Central) (Operadores que hablan inglés)

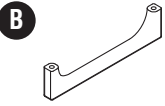
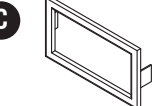



TOOLS REQUIRED: Phillips Screwdriver

Parts List			
Code	DESCRIPTION	Qty.	Part No.
(A)	Paper Holder	10	F63832A1

Hardware Pack F10115A6		
 B Handle Qty. 20 Z50493A8	 C Label Holder Qty. 10 Z50549A2	 D Screw Qty. 40 Z10337A2
 E Wire Qty. 20 Z50952A2	 F 6 foot rubber strip Qty. 1 Z50531A2	

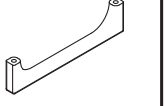
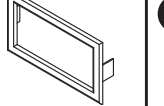

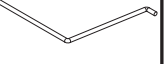

OUTILS REQUIS : Tournevis à pointe cruciforme

Liste des Pièces			
Code	DESCRIPTION	Qté	N° de Pièce
(A)	Presse-papier	10	F63832A1

Paquet Matériel F10115A6		
 B Poignée Qty. 20 Z50493A8	 C Porte-étiquette Qty. 10 Z50549A2	 D Vis Qty. 40 Z10337A2
 E Fil Qty. 20 Z50952A2	 F 6 bande de caoutchouc pied Qty. 1 Z50531A2	

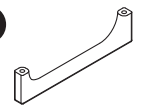
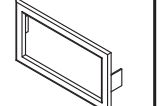
HERRAMIENTAS REQUERIDAS: Destornillador Phillips®

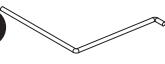
Lista de Piezas			
Código	DESCRIPCIÓN	Cant.	No. de Pieza
(A)	Pisapapeles	10	F63832A1

Paquete Material F10115A6		
 B Asa Qty. 20 Z50493A8	 C Etiqueta titular Qty. 10 Z50549A2	 D Tornillo Qty. 40 Z10337A2
 E Alambre Qty. 20 Z50952A2	 F 6 tira de goma del pie Qty. 1 Z50531A2	

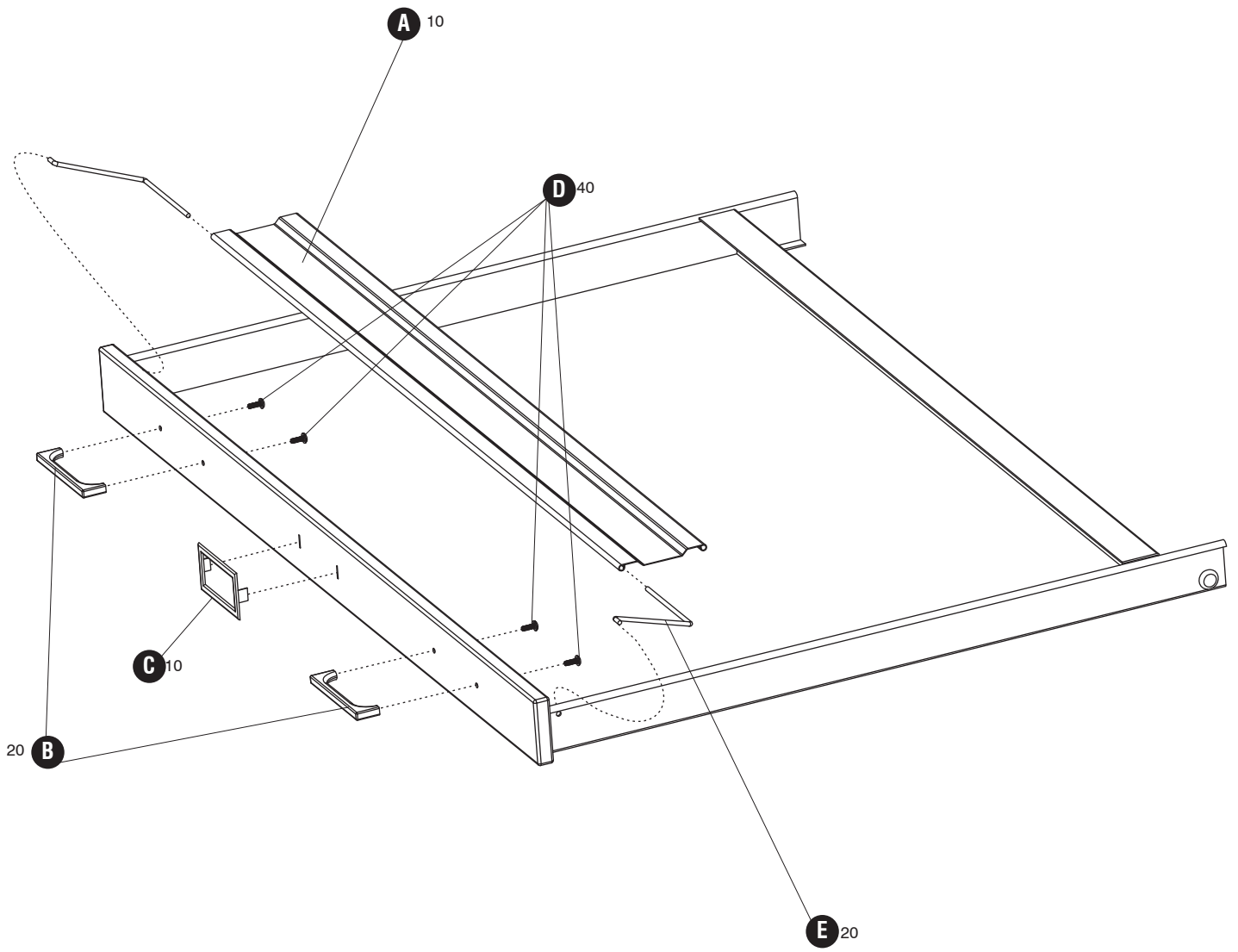

1

Note: Complete this step only if using one of the bases (Sold separately).

Note: Complétez cette étape seulement si vous utilisez l'une des socle (vendu séparément).

Nota: Realice este paso sólo si se utiliza una de las bases (se vende por separado).

Note: Remove the drawers before placing the cabinet on the base.

Note: Enlevez les tiroirs avant de placer du meuble sur la socle

Nota: Retire los cajones del gabinete antes de colocar en la base

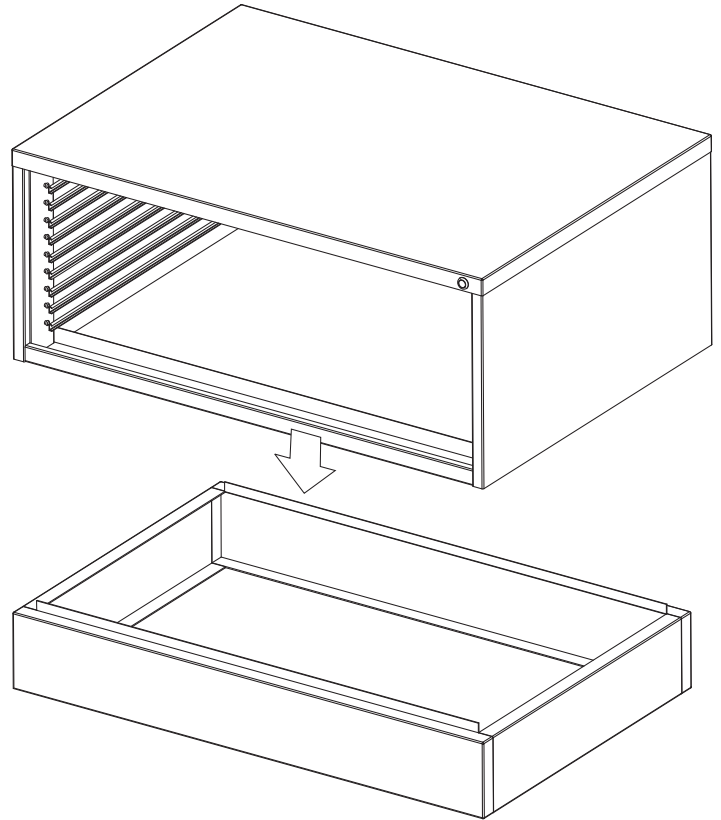

2

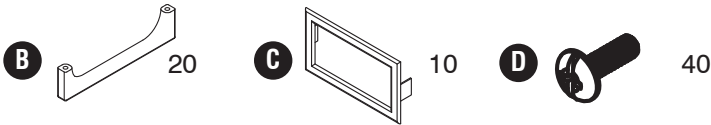

X 10

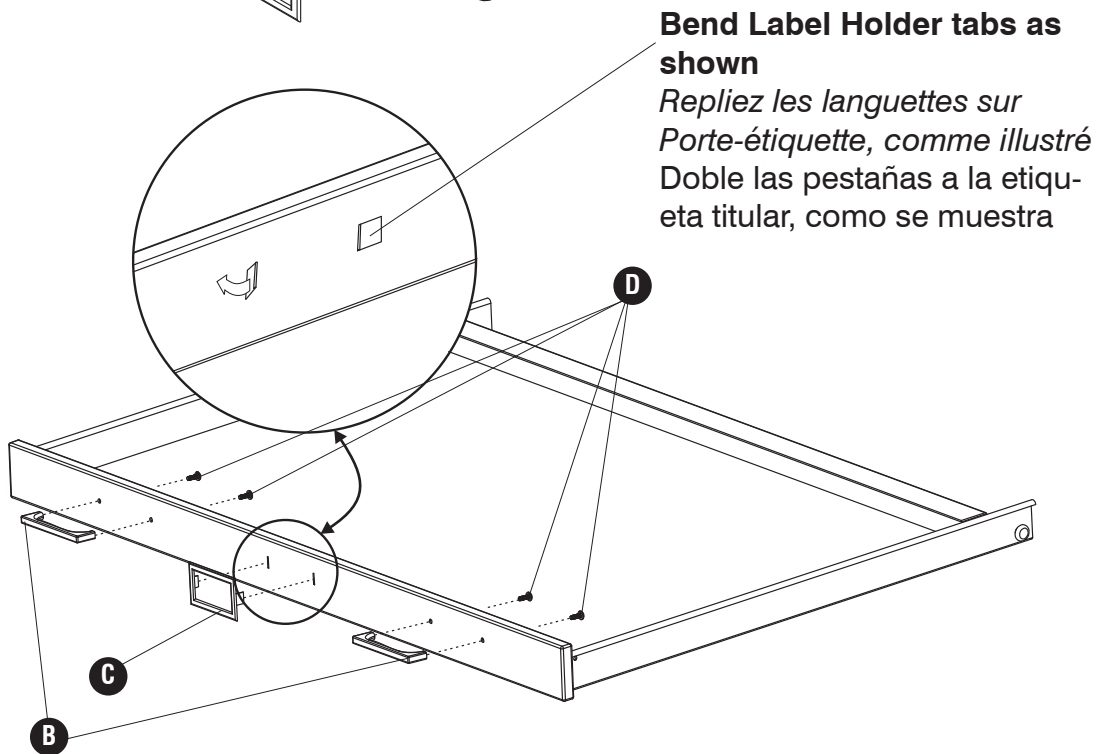

3
X 10

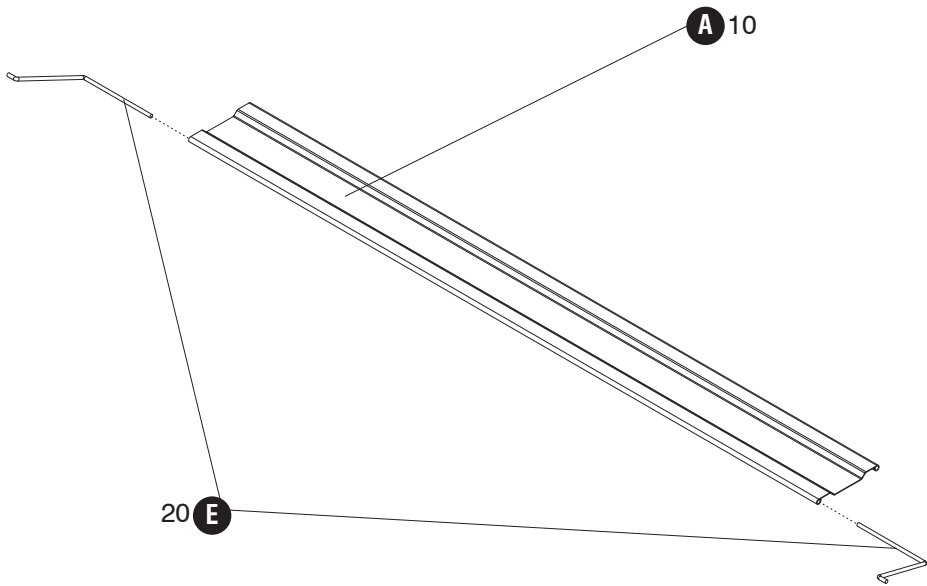
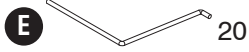

4
X 10

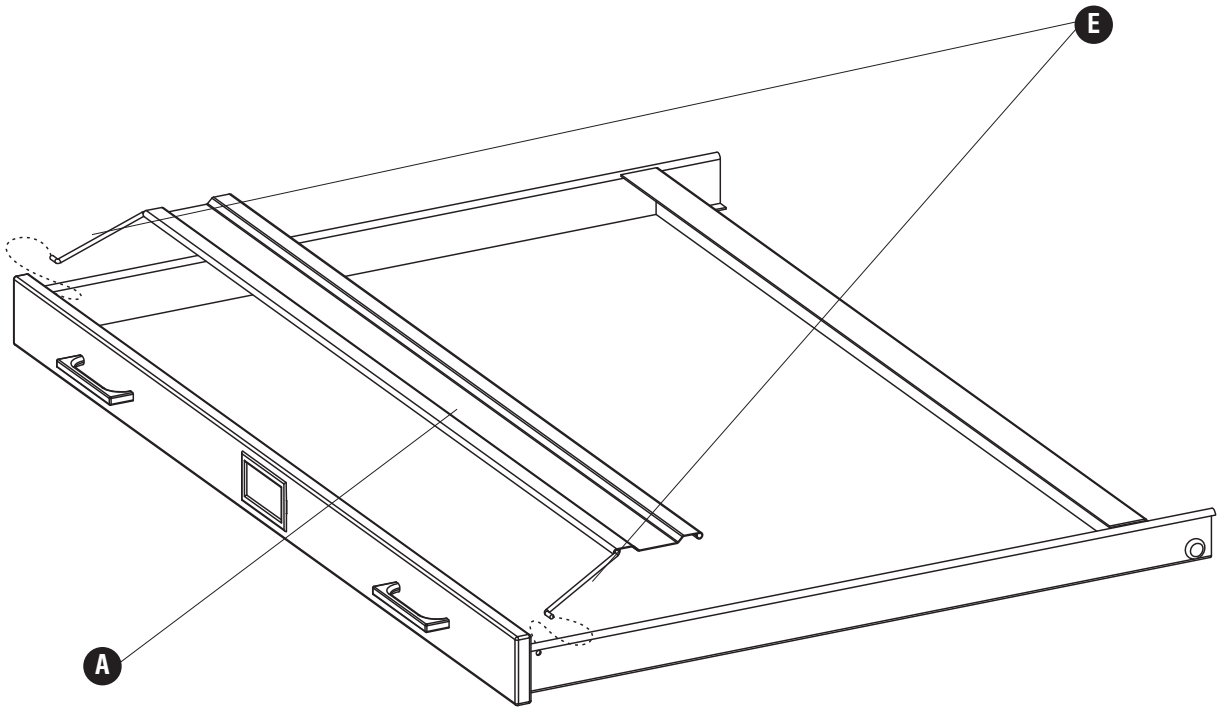

5 X 10

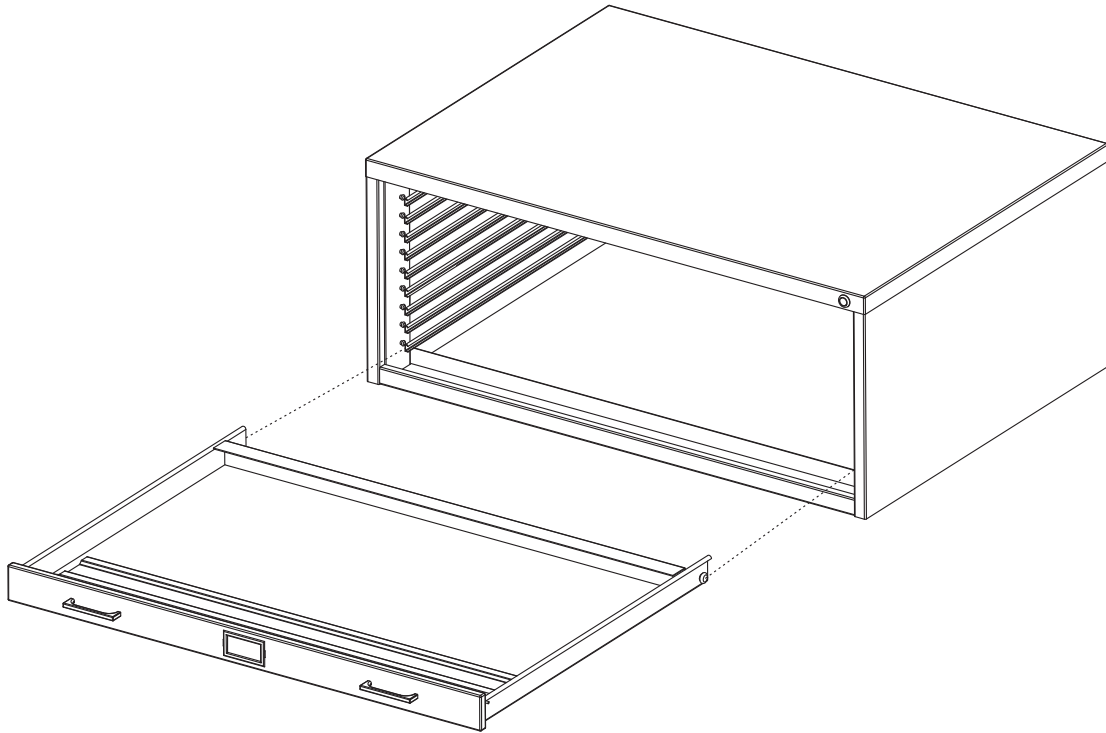

6

F 1

Note: Cut rubber strip to length then tape to cabinet as shown.

Note: Couper la bande en caoutchouc et de adhésif le dessus du meuble comme le montre.

Nota: Cortar la tira de goma y cinta adhesiva en la parte superior del gabinete como se muestra.

Note: Complete this step only if stacking 2 cabinets together.

Note: Si empilage de 2 meuble ensemble, utilisez cette étape.

Nota: Realice este paso sólo si apilamiento 2 armario

