

**ASSEMBLY INSTRUCTIONS**  
*INSTRUCCIONES DE MONTAJE*  
**INSTRUCCIONES DE ENSAMBLAJE**

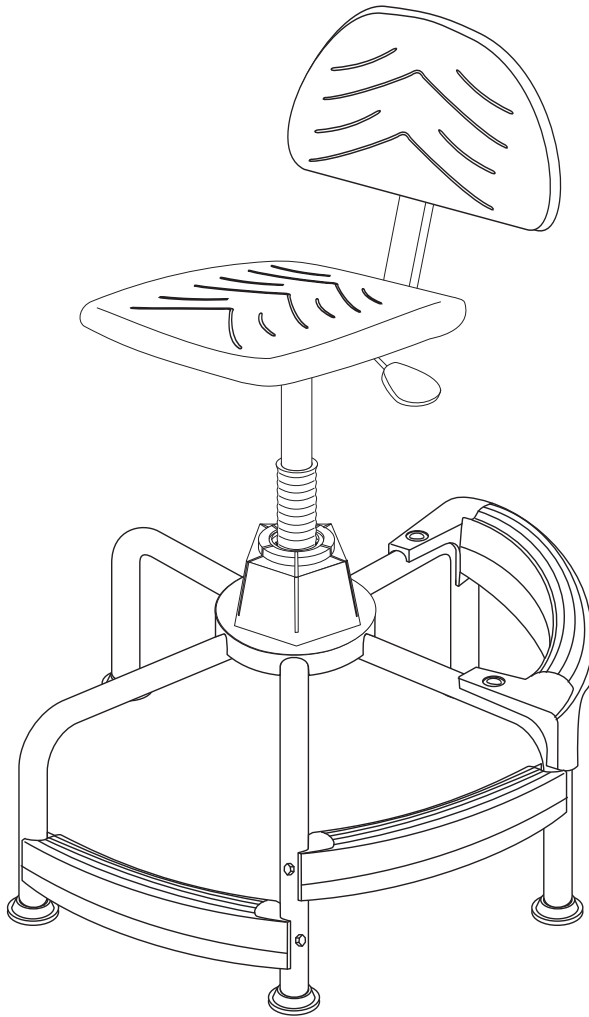

**5120**  
**TASK MASTER<sup>®</sup>**  
**INDUSTRIAL CHAIR**  
*CHAISE INDUSTRIELLE*  
**SILLA INDUSTRIAL**

**PRODUCT WARRANTY REGISTRATION** is available online at: [www.safcoproducts.com](http://www.safcoproducts.com)

• LA GARANTIE DU PRODUIT est  
disponible sur l'Internet : [www.safcoproducts.com](http://www.safcoproducts.com)

• LA GARANTÍA DEL PRODUCTO está  
disponible en la Internet: [www.safcoproducts.com](http://www.safcoproducts.com)

For questions or concerns, please call **1-800-664-0042**  
available Monday-Friday 7:30 AM to 5:00 PM (Central Time) (English-speaking operators)







Si vous avez des questions pour poser ou les préoccupations  
pour exprimer, connecter **au 1-800-664-0042**  
de 7H30 à 17H00 (Heure centrale) (Opérateurs de langue anglaise)

Si usted tiene preguntas o preocupaciones,  
por favor llame **1-800-664-0042**  
de 7:30 AM a 5:00 PM (Hora Central) (Operadores que hablan inglés)

PARTS LIST / LISTE DES PIÈCES / LISTA DE PIEZAS

CODE / CODIGO	DESCRIPTION / DESCRIPTION / DESCRIPCIÓN	QTY. / QUANTITÉ / CANTIDAD	PART NO. / N° DE PIECE / NO. DE PIEZA
(A)	<b>Seat Assembly / Ensemble de siège / Asiento de montaje</b>	1	5113-51BL
(B)	<b>Backrest Assembly / Retour assemblé repose- / conjunto de respaldo</b>	1	5113-52BL
(C)	<b>Base / Pied / Base</b>	1	5101-54BL
(D)	<b>Cylinder / Cylindre / Cilindro</b>	1	5101-61
(E)	<b>Tapered Bushing / Douille conique / Buje cónico</b>	1	5101-05BL
(F)	<b>Footrest Bottom / Repose-pied inférieur / Reposapiés fondo</b>	2	5101-06BL
(G)	<b>Footrest Top / Repose-pied haut / Reposapiés superior</b>	1	5118-06BL

Hardware Pack / Paquet Matériel / Paquete Material:  
5120-19NC

<b>H</b> 	<b>I</b> 	<b>J</b> 	<b>K</b> 	<b>L</b> 	<b>M</b> 
<b>Square nut</b> Écrou à angle droit Tuerca cuadrada Qty. / Qté. / Cant. 4 5101-24NC	<b>Screw</b> Vis Tornillo Qty. / Qté. / Cant. 4 5101-23NC	<b>Washer</b> Rondelle Arandela Qty. / Qté. / Cant. 6 5147-31NC	<b>Glide</b> Glissière Deslizador Qty. / Qté. / Cant. 5 5101-25BL	<b>Bolt</b> Boulon Tornillo Qty. / Qté. / Cant. 2 5118-23NC	<b>Nut</b> Écrou Tuerca Qty. / Qté. / Cant. 2 5118-24NC

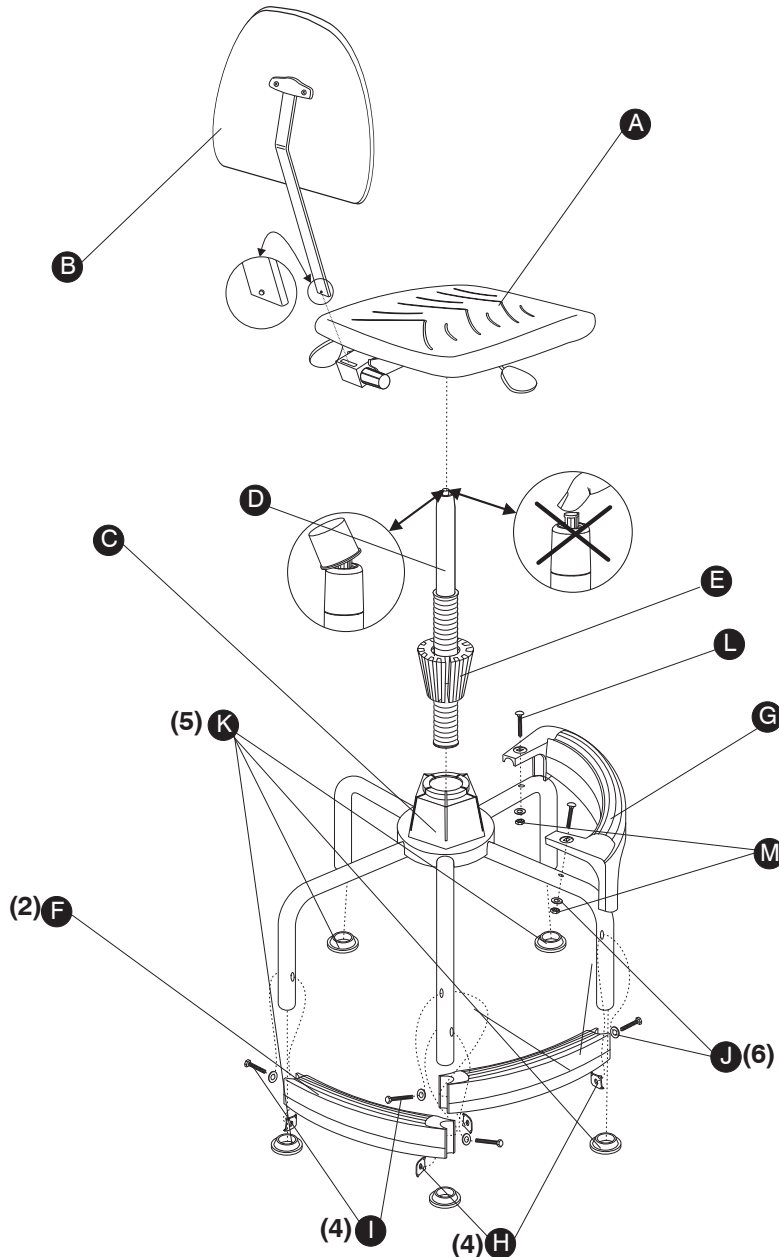

**1**

**H** (4) **I** (4) **J** (4) **K** (5) **L** (2) **M** (2)

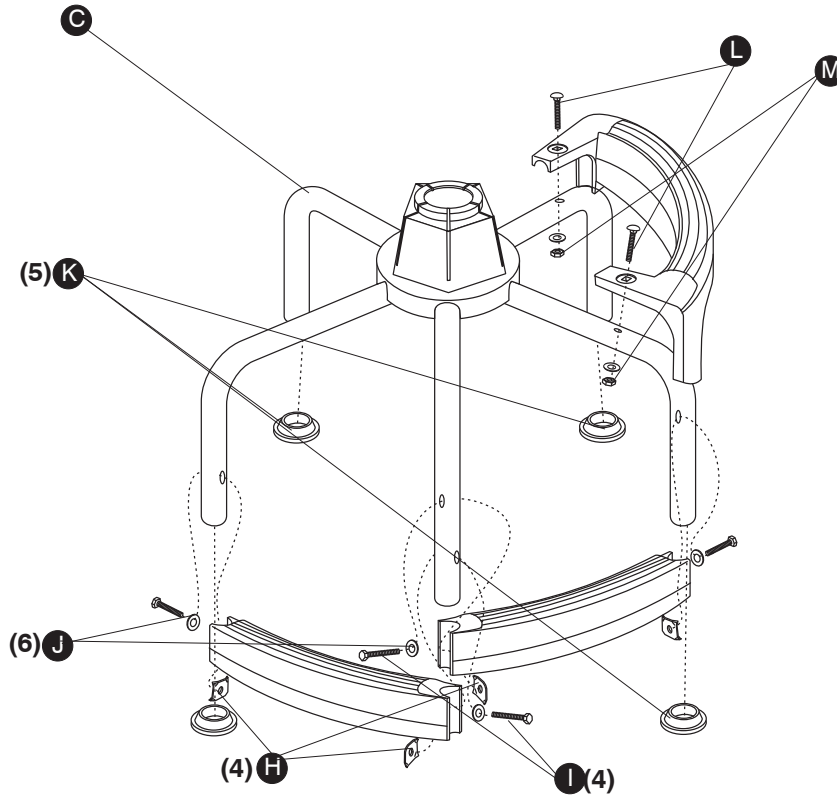
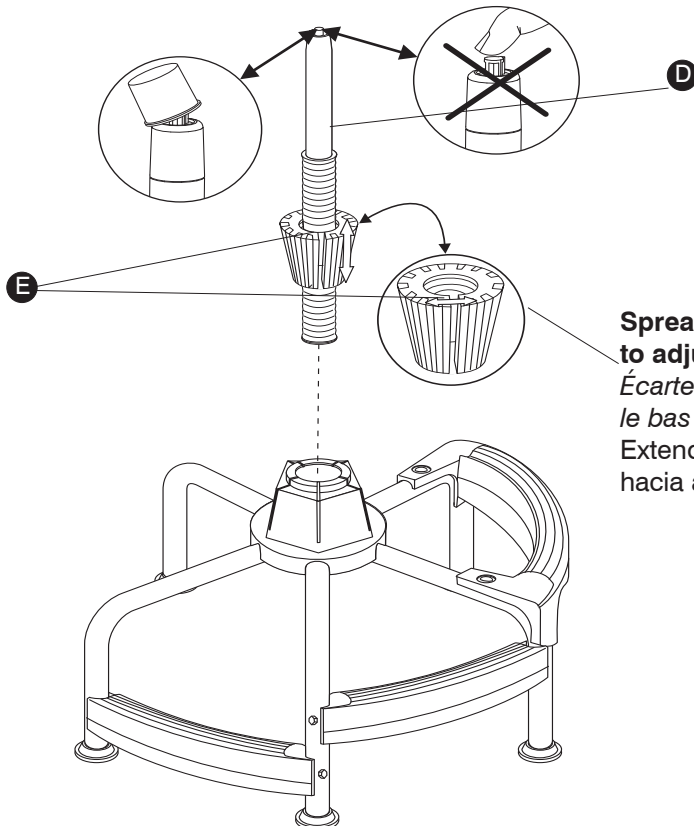
**2**

**Spread bushing slightly and move up or down to adjust the height of the cylinder on the base.**  
*Écarter légèrement douille et déplacer vers le haut ou vers le bas pour ajuster la hauteur du cylindre la sur base.*  
 Extendidos ligeramente del buje y moverse hacia arriba o hacia abajo para ajustar la altura del cilindro en la base.

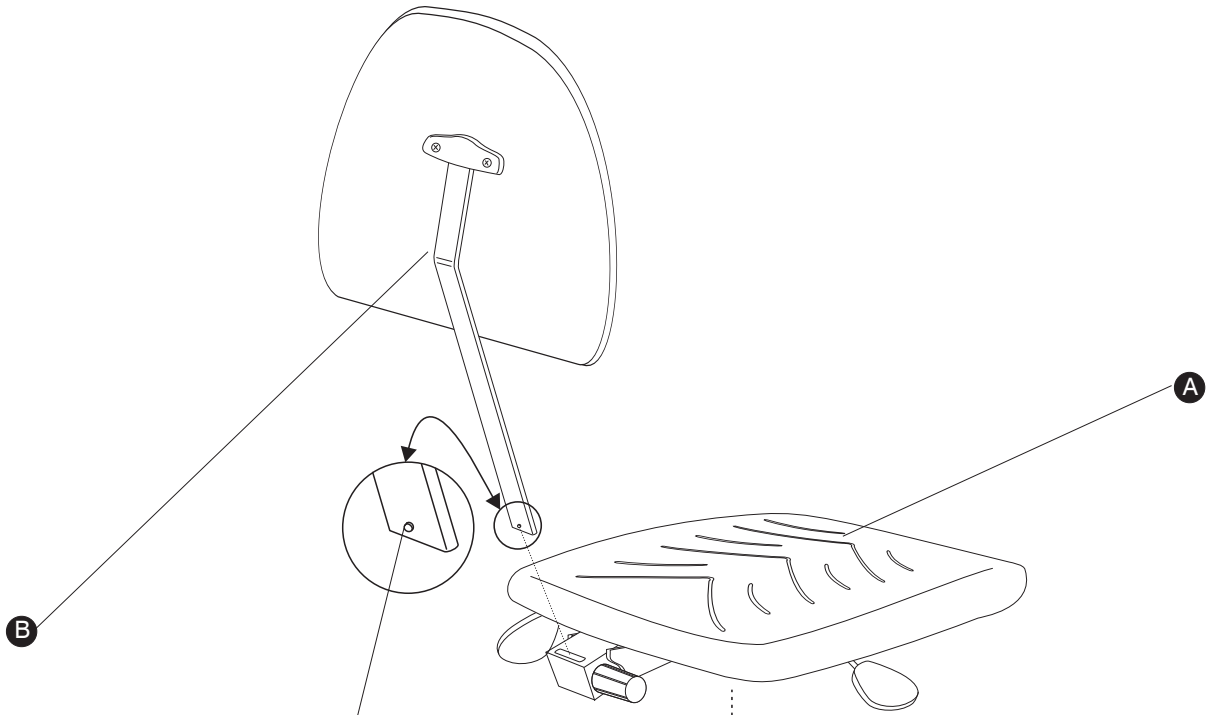

**Press button to insert back**  
*Appuyez sur le bouton pour insérer retour*  
Pulse el botón para insertar la parte posterior

