

**ASSEMBLY INSTRUCTIONS**  
*INSTRUCTIONS DE MONTAGE*  
**INSTRUCCIONES DE ENSAMBLAJE**

**9231**

**E-Z Stor**<sup>®</sup>

**Literature Organizer (60 Compartments)**

*Classeur de Documents (à 60 Cases)*

Casillero para Publicaciones (60 Compartimientos)

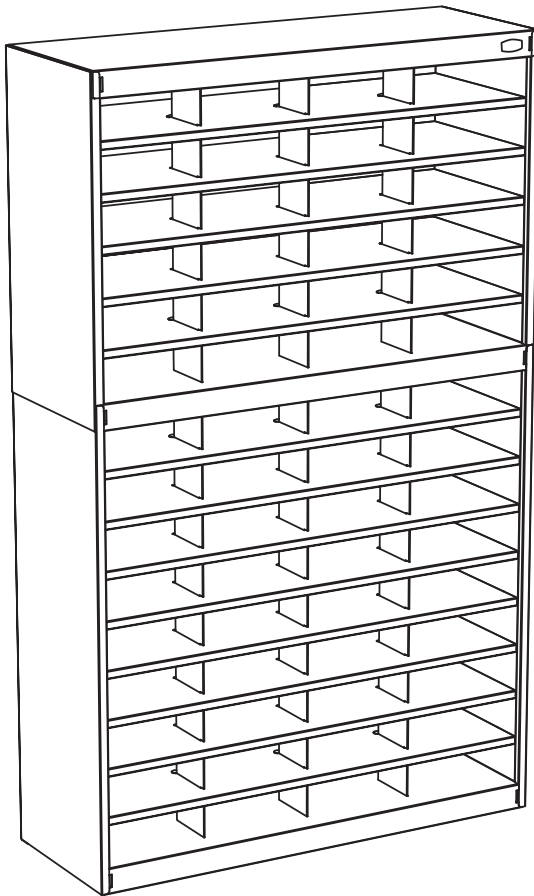

**PRODUCT WARRANTY REGISTRATION** is available online at: [www.safcoproducts.com](http://www.safcoproducts.com)

• LA GARANTIE DU PRODUIT est  
disponible sur l'Internet : [www.safcoproducts.com](http://www.safcoproducts.com)

• LA GARANTÍA DEL PRODUCTO está  
disponible en la Internet: [www.safcoproducts.com](http://www.safcoproducts.com)

For questions or concerns, please call **1-800-664-0042**  
available Monday-Friday 7:30 AM to 5:00 PM (Central Time) (English-speaking operators)

Si vous avez des questions pour poser ou les préoccupations  
pour exprimer, connecter **au 1-800-664-0042**  
de 7H30 à 17H00 (Heure centrale) (Opérateurs de langue anglaise)



Si usted tiene preguntas o preocupaciones,  
por favor llame **1-800-664-0042**  
de 7:30 AM a 5:00 PM (Hora Central) (Operadores que hablan inglés)

## TOOLS REQUIRED: Phillips Screwdriver

### PARTS LIST

| CODE | DESCRIPTION            | QTY. | PART NO.  |
|------|------------------------|------|-----------|
| (A)  | 2" Shelf, Plain        | 2    | 9211-51§  |
| (B)  | 2" Shelf, with Label   | 1    | 9211-52§  |
| (C)  | 5/8" Shelf             | 13   | 9211-53§  |
| (D)  | Lower Outer Side Panel | 2    | 9221-54§  |
| (E)  | Upper Outer Side Panel | 2    | 9231-54§  |
| (F)  | Lower Inner Side Panel | 2    | 9221-55§  |
| (G)  | Upper Inner Side Panel | 2    | 9211-55§  |
| (H)  | Lower Fiber Back Panel | 1    | 9221-57BL |
| (I)  | Upper Fiber Back Panel | 1    | 9211-57BL |
| (J)  | Lower Divider          | 3    | 9221-56§  |
| (K)  | Upper Divider          | 3    | 9211-56§  |
| (L)  | Hardware Pack          | 1    | 9231-69NC |

### HARDWARE PACK 9231-69NC

|   |   |   |
|---|---|---|
| <b>M</b><br> | <b>N</b><br> | <b>O</b><br> |
| <b>Plastic Button</b><br>Qty.: 12<br>#9211-61NC   | <b>Screw</b><br>Qty.: 12<br>#9211-77NC  | <b>Shim</b><br>Qty.: 2<br>#9231-62NC  |



§ Note: When corresponding about parts, be sure to state color: Gray (GR), Tropic Sand (TS) or Black (BL).

## OUTILS REQUIS : Tournevis à pointe cruciforme

### LISTE DES PIÈCES

| CODE | DESCRIPTION                          | QUANTITÉ | N° DE PIECE |
|------|--------------------------------------|----------|-------------|
| (A)  | Tablette 5 cm (2 po), ordinaire      | 2        | 9211-51§    |
| (B)  | Tablette 5 cm (2 po), avec étiquette | 1        | 9211-52§    |
| (C)  | Tablette 1.5 cm (5/8 po)             | 13       | 9211-53§    |
| (D)  | Panneau latéral extérieur inférieur  | 2        | 9221-54§    |
| (E)  | Panneau latéral extérieur supérieur  | 2        | 9231-54§    |
| (F)  | Panneau latéral intérieur inférieur  | 2        | 9221-55§    |
| (G)  | Panneau latéral intérieur supérieur  | 2        | 9211-55§    |
| (H)  | Panneau de fond de fibres inférieur  | 1        | 9221-57BL   |
| (I)  | Panneau de fond de fibres supérieur  | 1        | 9211-57BL   |
| (J)  | Séparateur inférieur                 | 3        | 9221-56§    |
| (K)  | Séparateur supérieur                 | 3        | 9211-56§    |
| (L)  | Paquet Matériel                      | 1        | 9231-69NC   |

### PAQUET MATÉRIEL 9231-69NC

|   |   |  |
|---|---|--|
| <b>M</b><br> | <b>N</b><br> | <b>O</b><br> |
| <b>Bouton en plastique</b><br>Qte.: 12<br>#9211-61NC  | <b>Vis</b><br>Qte.: 12<br>#9211-77NC  | <b>Cale d'épaisseur</b><br>Qte.: 2<br>#9231-62NC   |



§ Noter : Quand correspondre au sujet de parties, soyez sûr d'affirmer la couleur: Gris (GR), Sable Tropicque (TS) ou Noir (BL).

## HERRAMIENTAS REQUERIDAS: Destornillador Phillips®

### LISTA DE PIEZAS

| CODIGO | DESCRIPCIÓN                          | CANTIDAD | NO. DE PIEZA |
|--------|--------------------------------------|----------|--------------|
| (A)    | Repisa de 5 cm (2"), llano           | 2        | 9211-51§     |
| (B)    | Repisa de 5 cm (2"), con la etiqueta | 1        | 9211-52§     |
| (C)    | Repisa de 1.5 cm (5/8")              | 13       | 9211-53§     |
| (D)    | Panel exterior lateral inferior      | 2        | 9221-54§     |
| (E)    | Panel exterior lateral superior      | 2        | 9231-54§     |
| (F)    | Panel interior lateral inferior      | 2        | 9221-55§     |
| (G)    | Panel interior lateral superior      | 2        | 9211-55§     |
| (H)    | Panel posterior de fibra inferior    | 1        | 9221-57BL    |
| (I)    | Panel posterior de fibra superior    | 1        | 9211-57BL    |
| (J)    | Separador inferior                   | 3        | 9221-56§     |
| (K)    | Separador superior                   | 3        | 9211-56§     |
| (L)    | Paquete Material                     | 1        | 9231-69NC    |

### PAQUETE MATERIAL 9231-69NC

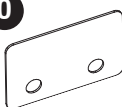
|   |   |   |
|---|---|---|
| <b>M</b><br> | <b>N</b><br> | <b>O</b><br> |
| <b>Botón de plástico</b><br>Cant.: 12<br>#9211-61NC   | <b>Tornillo</b><br>Cant.: 12<br>#9211-77NC  | <b>Cuña</b><br>Cant.: 2<br>#9231-62NC   |

§ Note: Al corresponder sobre las piezas, esté seguro declarar el color: Gris (GR), Arena Tropical (TS) o Negro (BL)

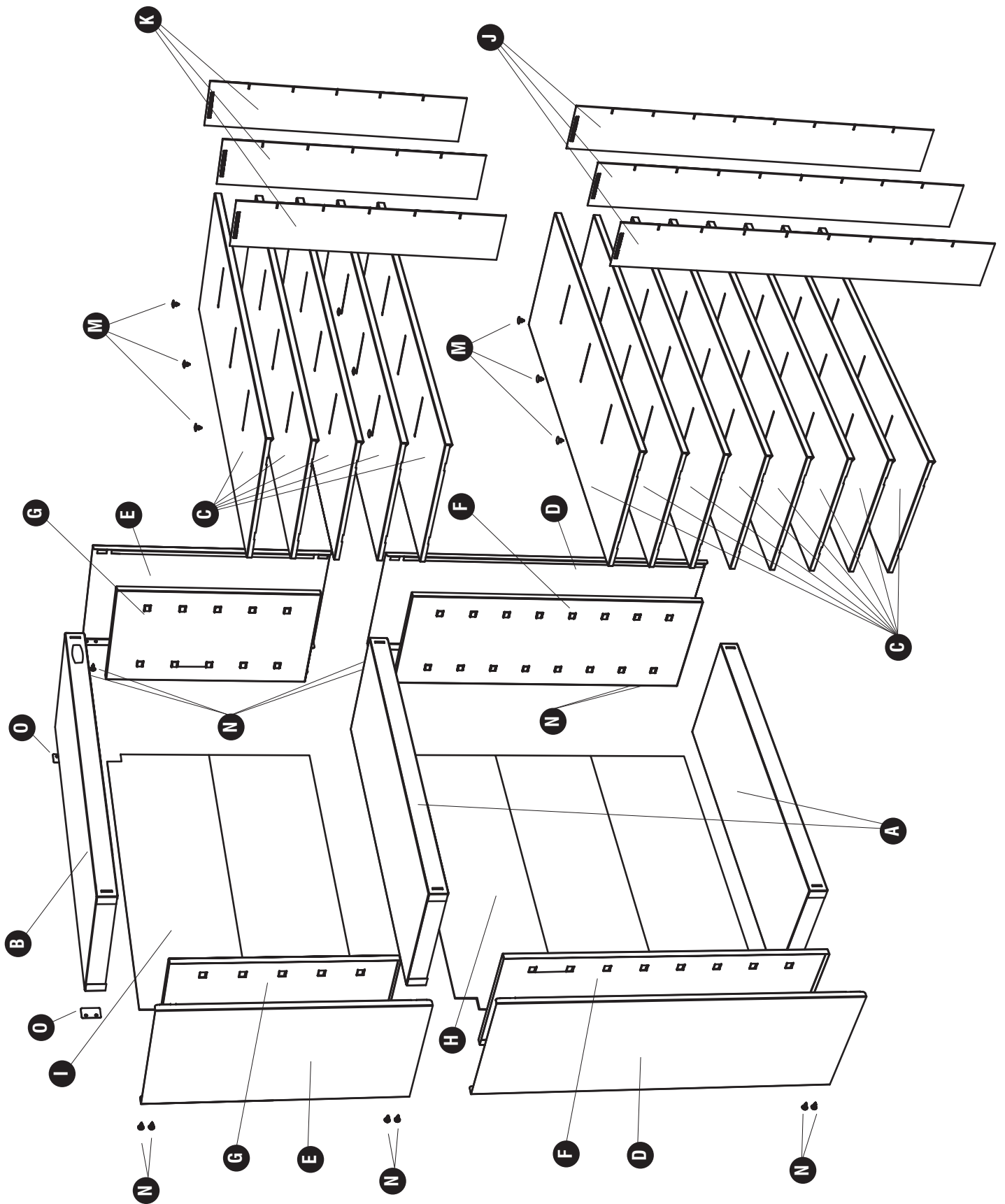

**1** **N**  (4)

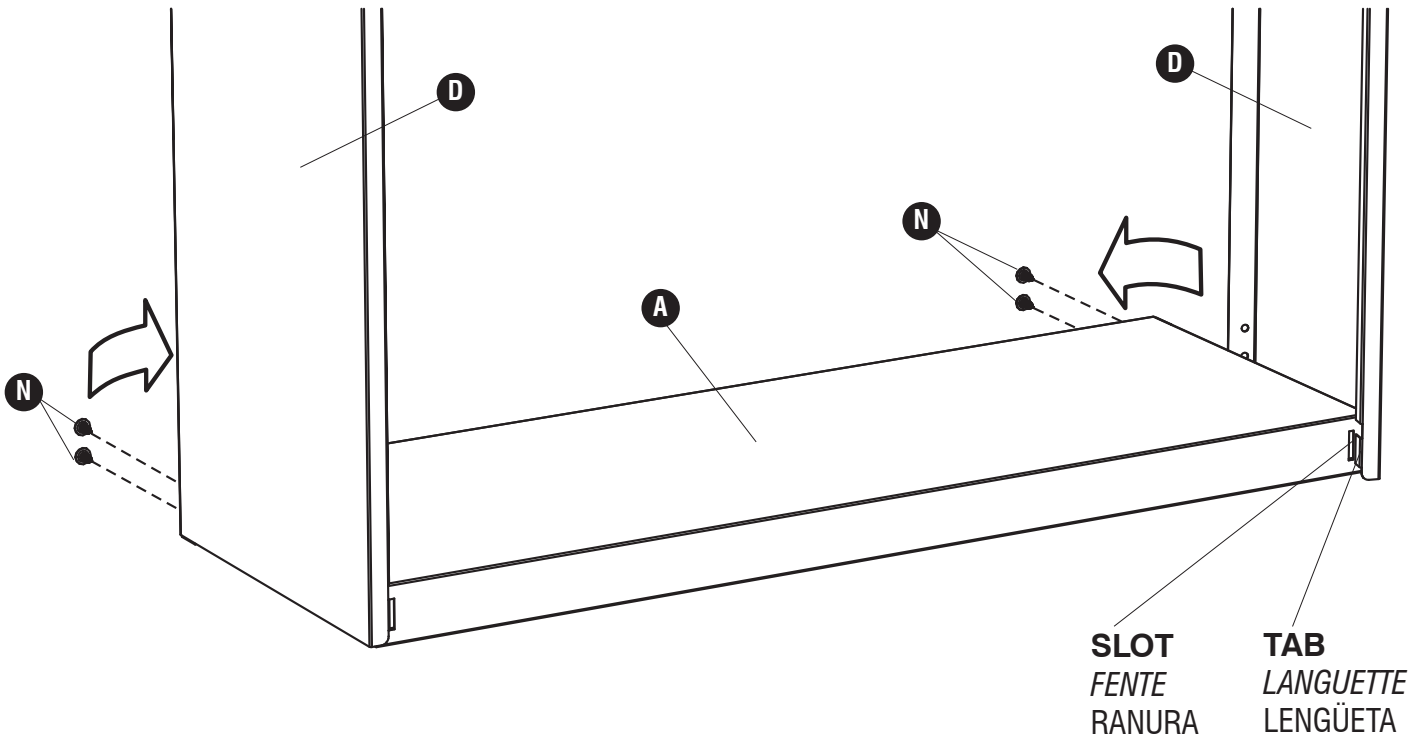

**2**

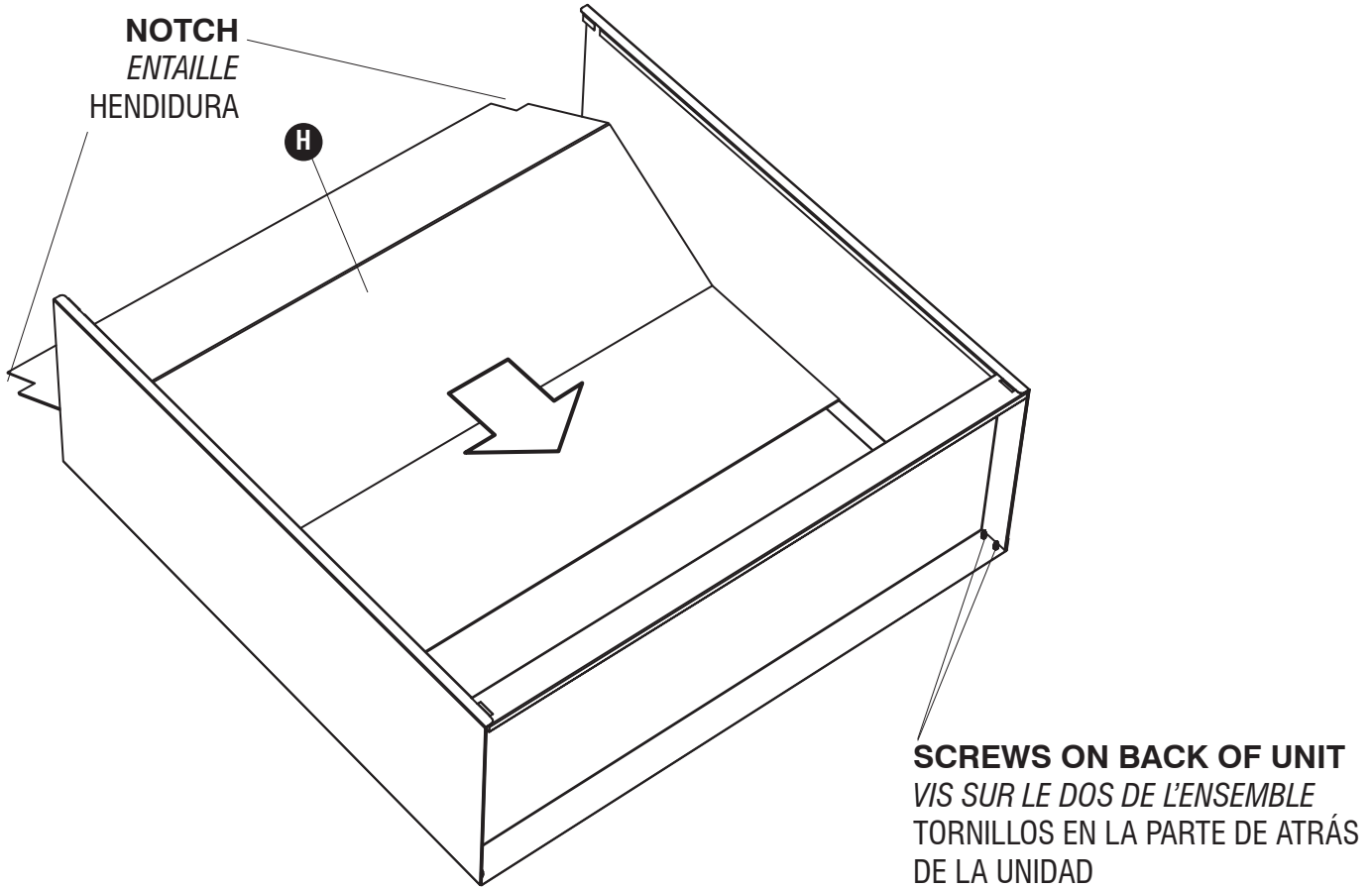

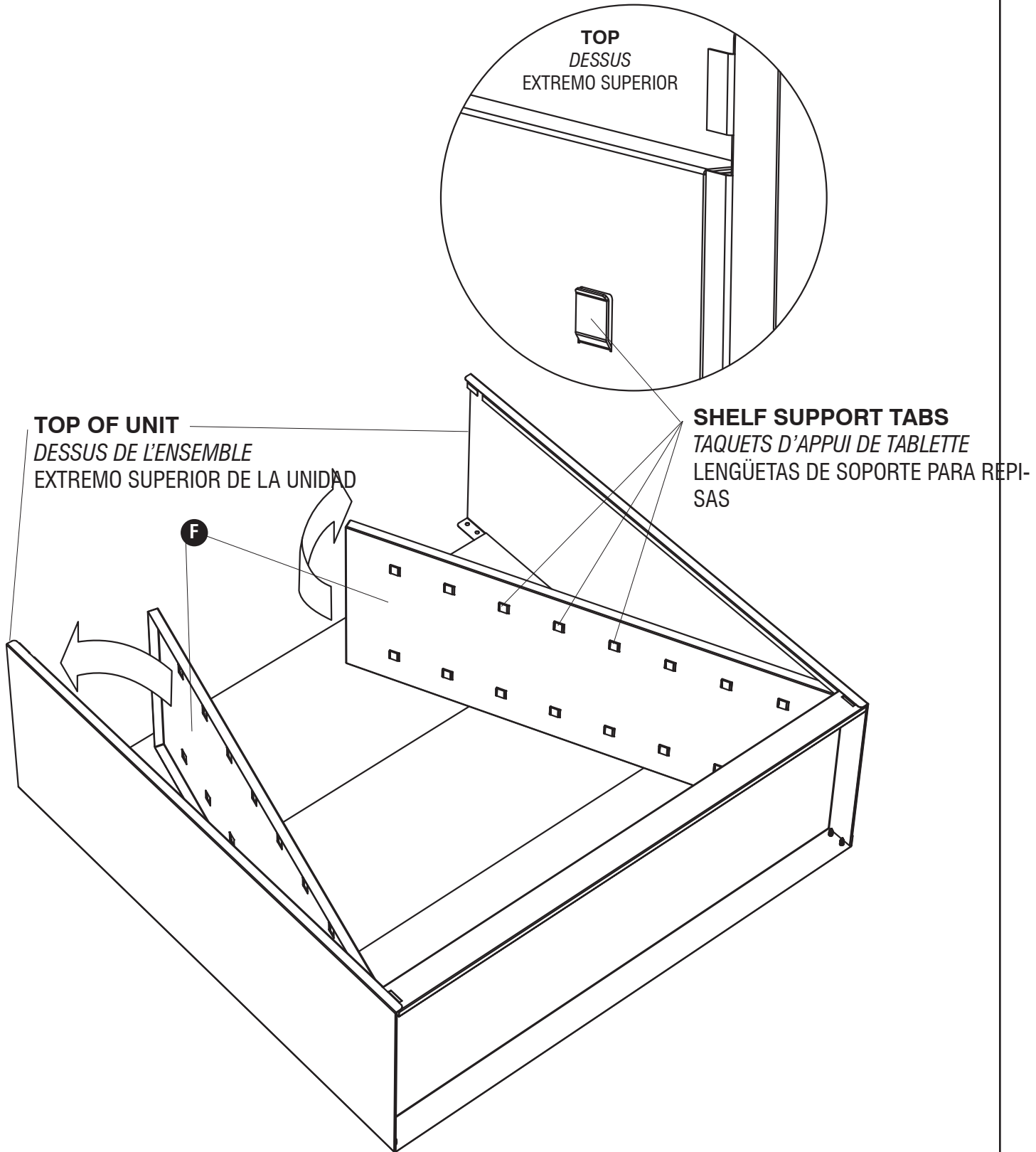

4

**SHELF NOTCH**  
*ENTAILLE DE TABLETTE*  
*HENDIDURA DE LA REPISA*

**SHELF SUPPORT TABS**  
*TAQUETS D'APPUI DE TABLETTE*  
*LENGÜETAS DE SOPORTE PARA REPISAS*

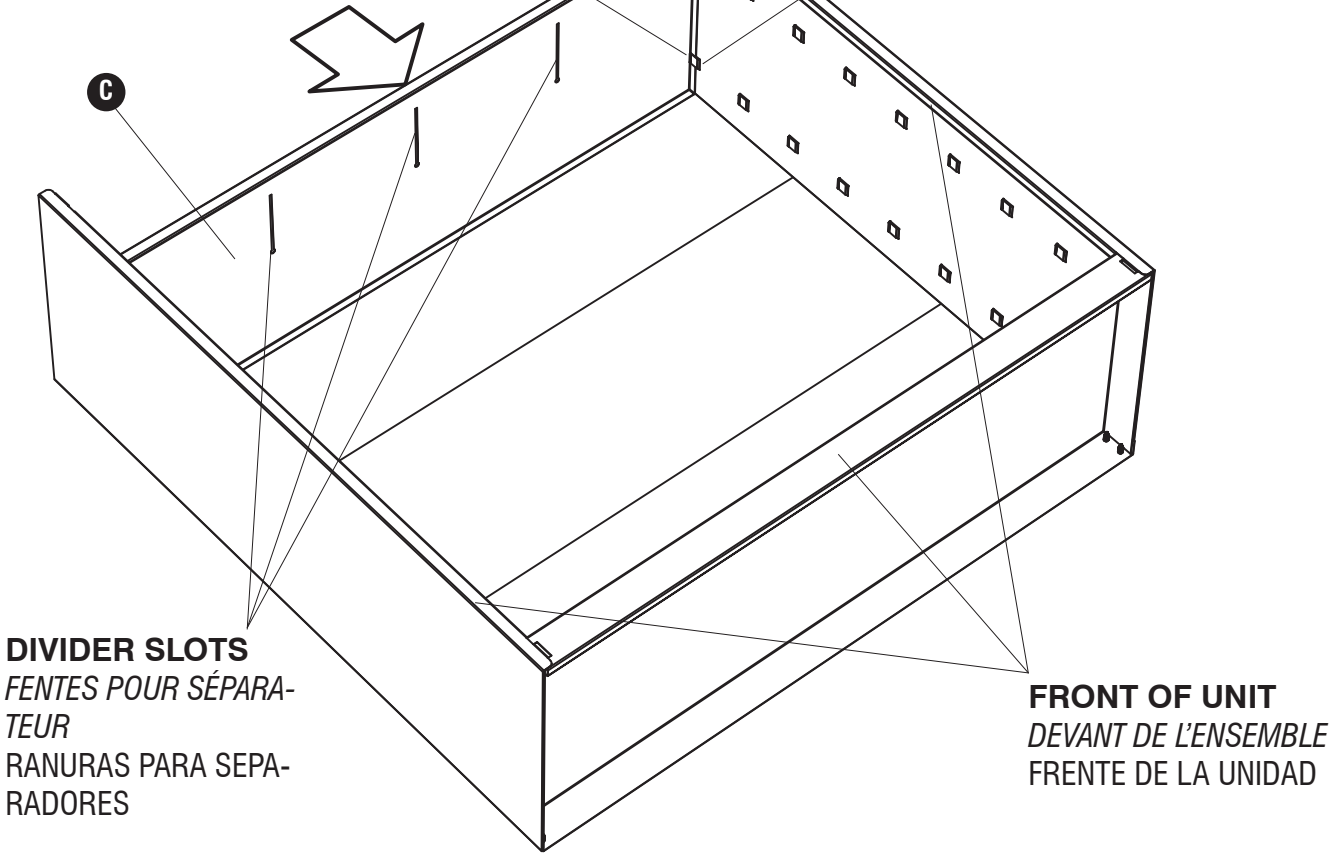

5

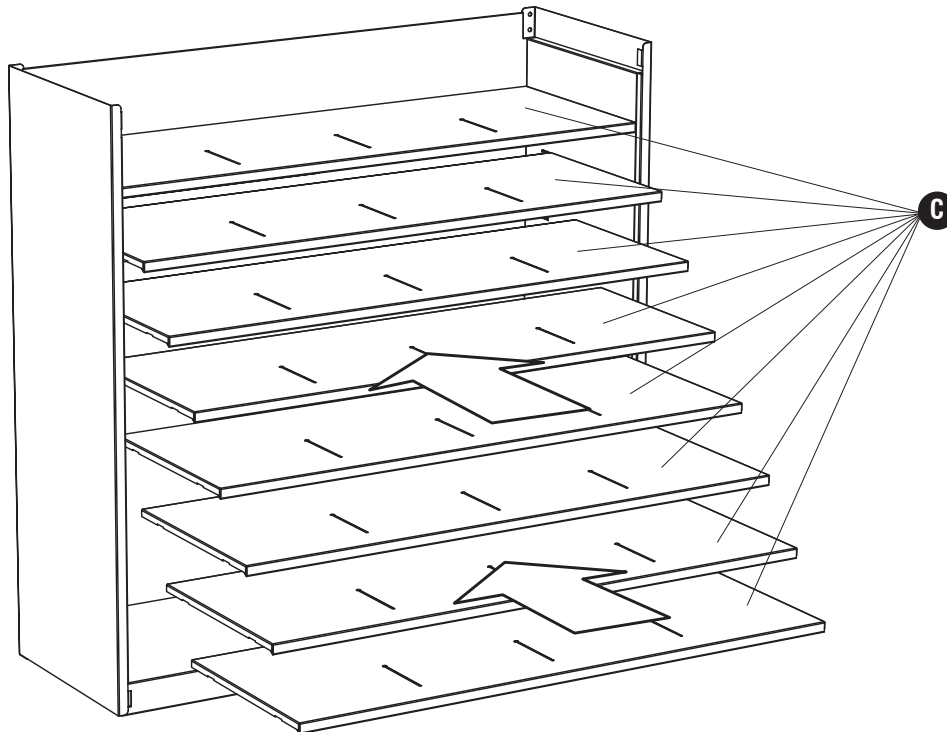

6

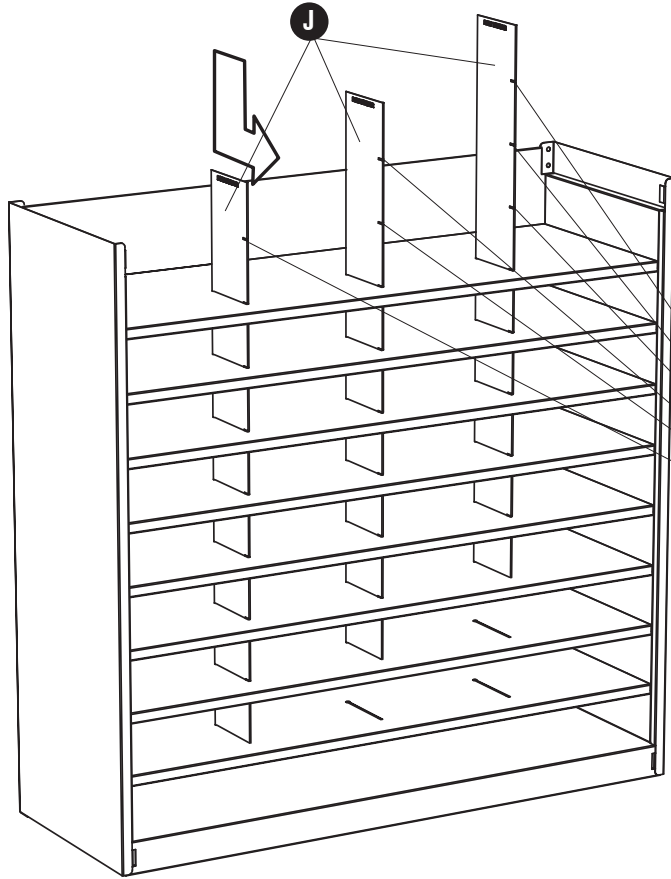

**IMPORTANT: STAMPED PART NUMBER GOES AT TOP OF UNIT**  
*ATTENTION : S'ASSURER QUE LE NUMÉRO DE PIÈCE IMPRIMÉ SE TROUVE VERS LE HAUT DE L'ENSEMBLE.*  
**IMPORTANTE: EL NÚMERO DE PIEZA DEBE QUEDAR EN LA PARTE SUPERIOR DE LA UNIDAD.**

**LOCKING SLOTS**  
*FENTES DE BLOCAGE*  
**HENDIDURAS DE FIJACIÓN**

7

M



(6)

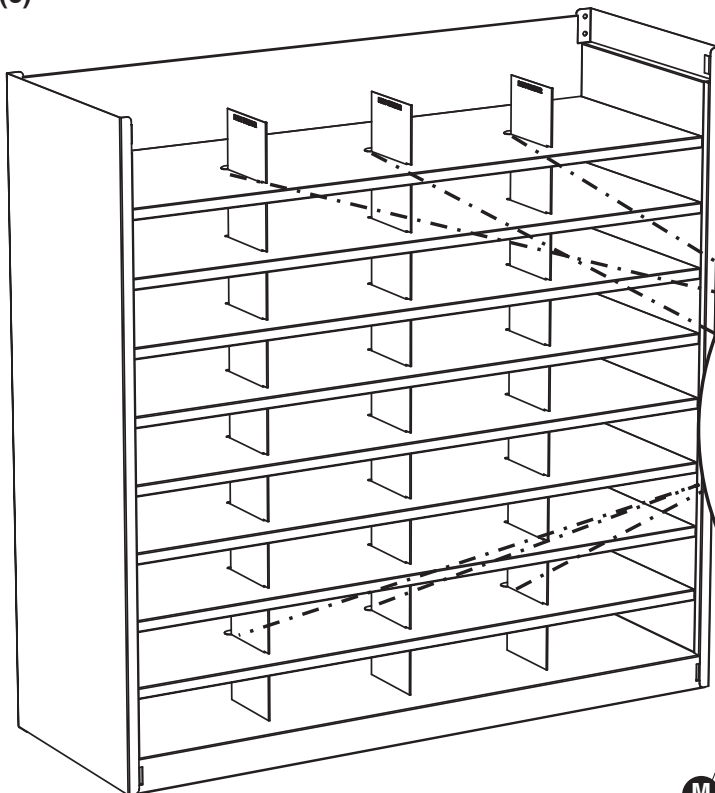

M

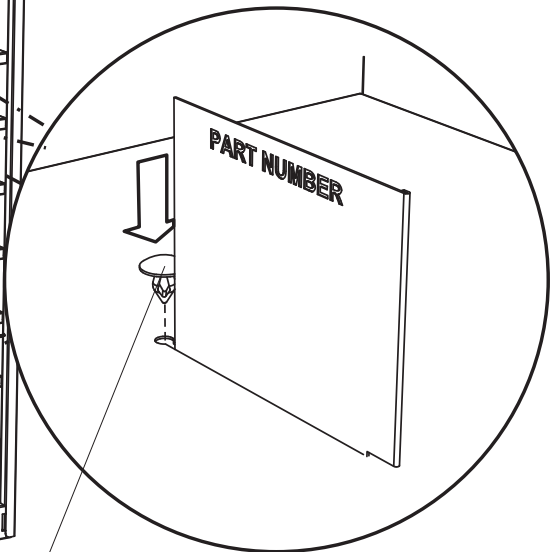

**IMPORTANT: BACK PANEL GOES INSIDE SHELF**

*ATTENTION : S'ASSURER QUE LE PANNEAU DE FOND SE TROUVE À L'INTÉRIEUR DE L'TABLETTE.*

*IMPORTANTE: EL PANEL POSTERIOR DEBE QUEDAR EN EL INTERIOR DE LA REPISA.*

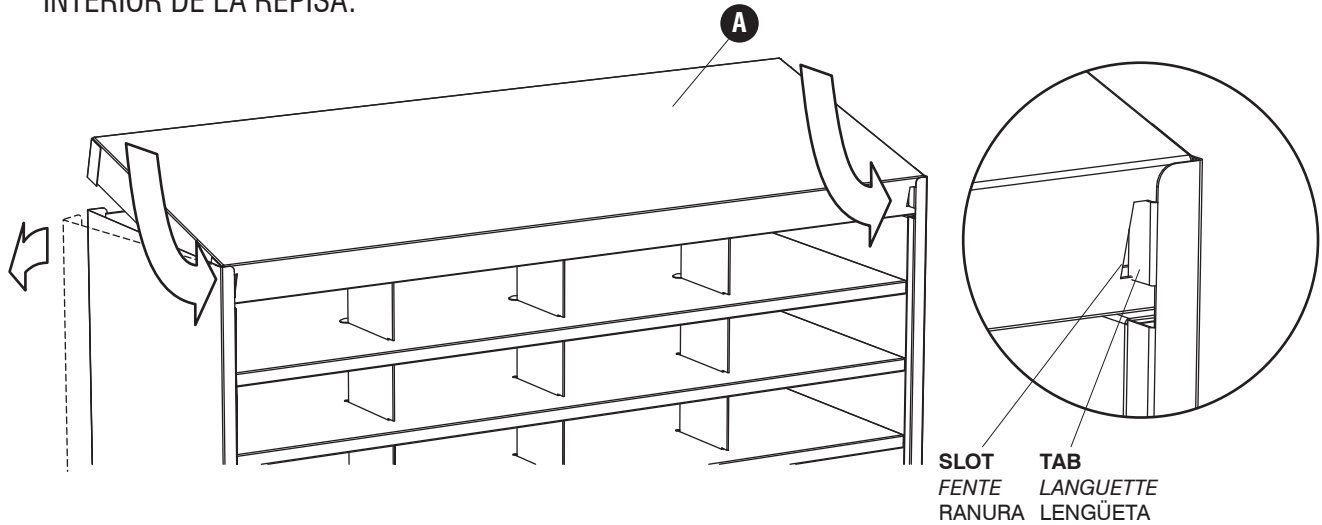

9 N (4)

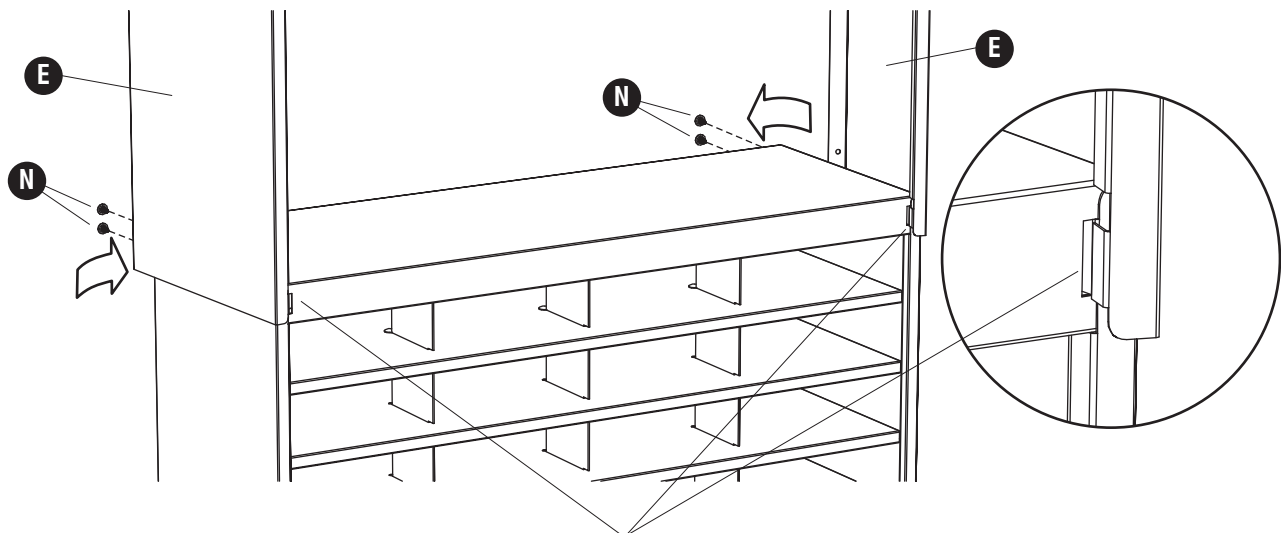
**SAME SLOT USED BY LOWER PANEL**

*LA MÊME FENTE QU'UTILISE LE PANNEAU INFÉRIEUR*

*MISMA RANURA QUE SE UTILIZÓ PARA EL PANEL INFERIOR*



NOTCH  
ENTAILLE  
HENDIDURA

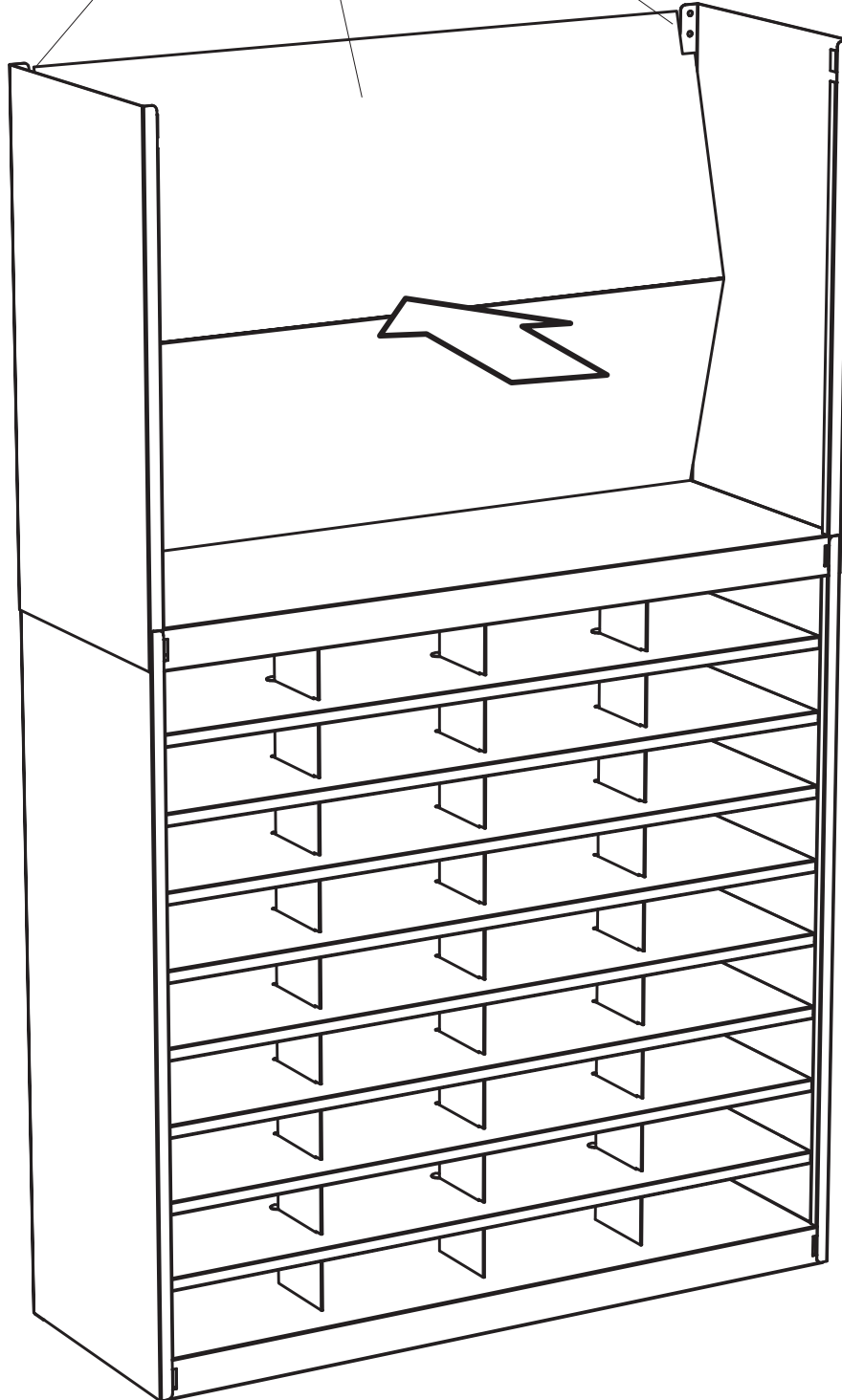

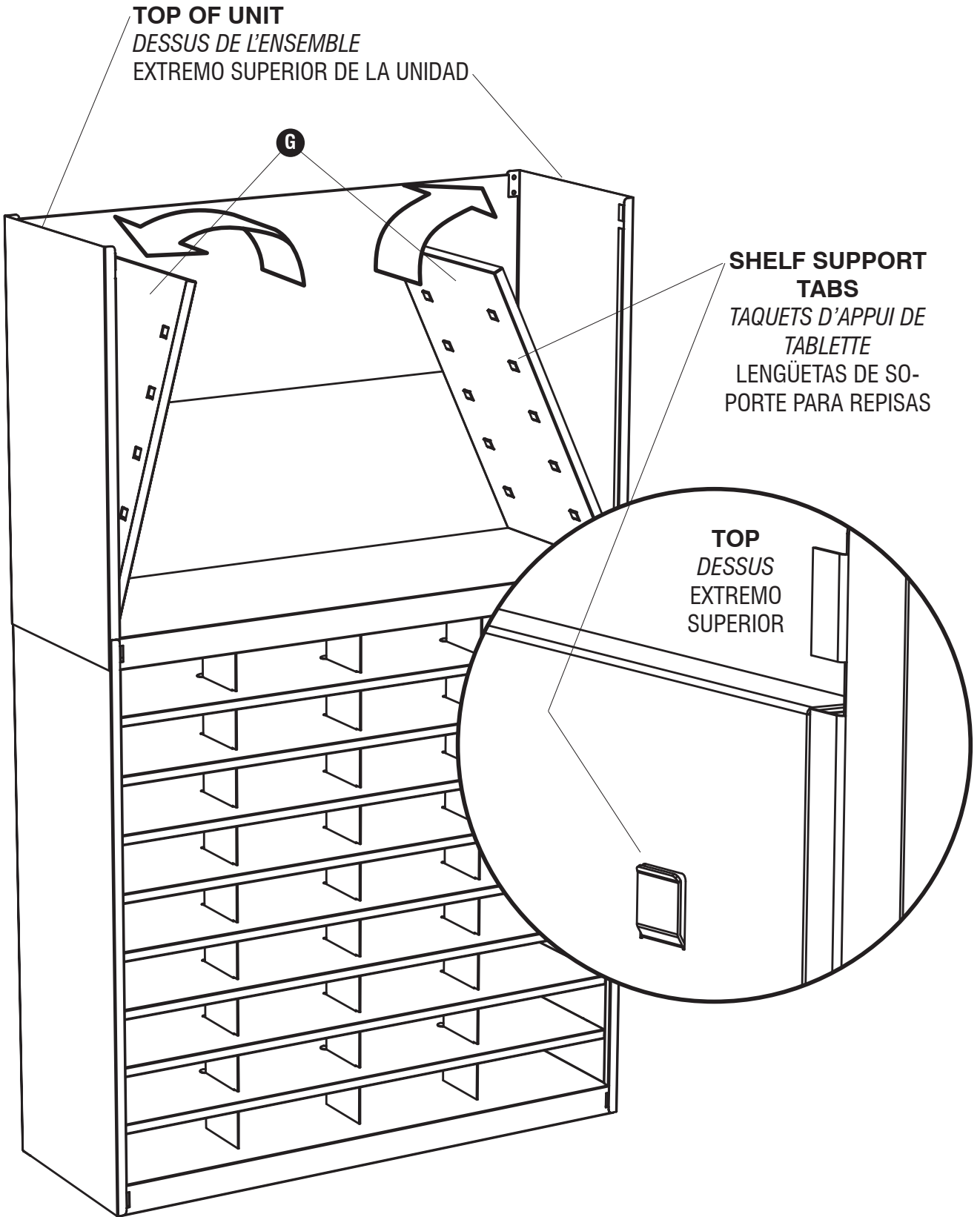

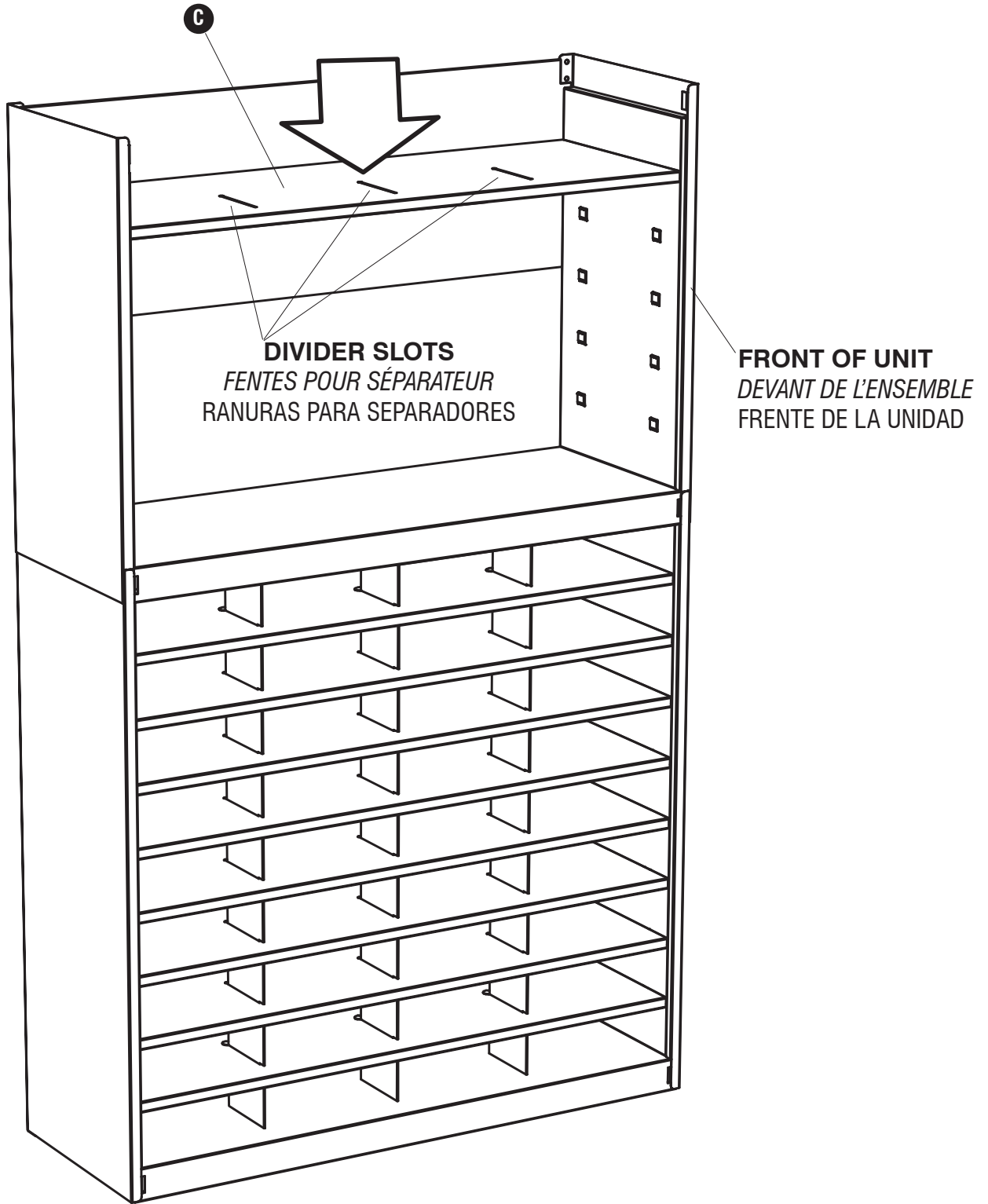

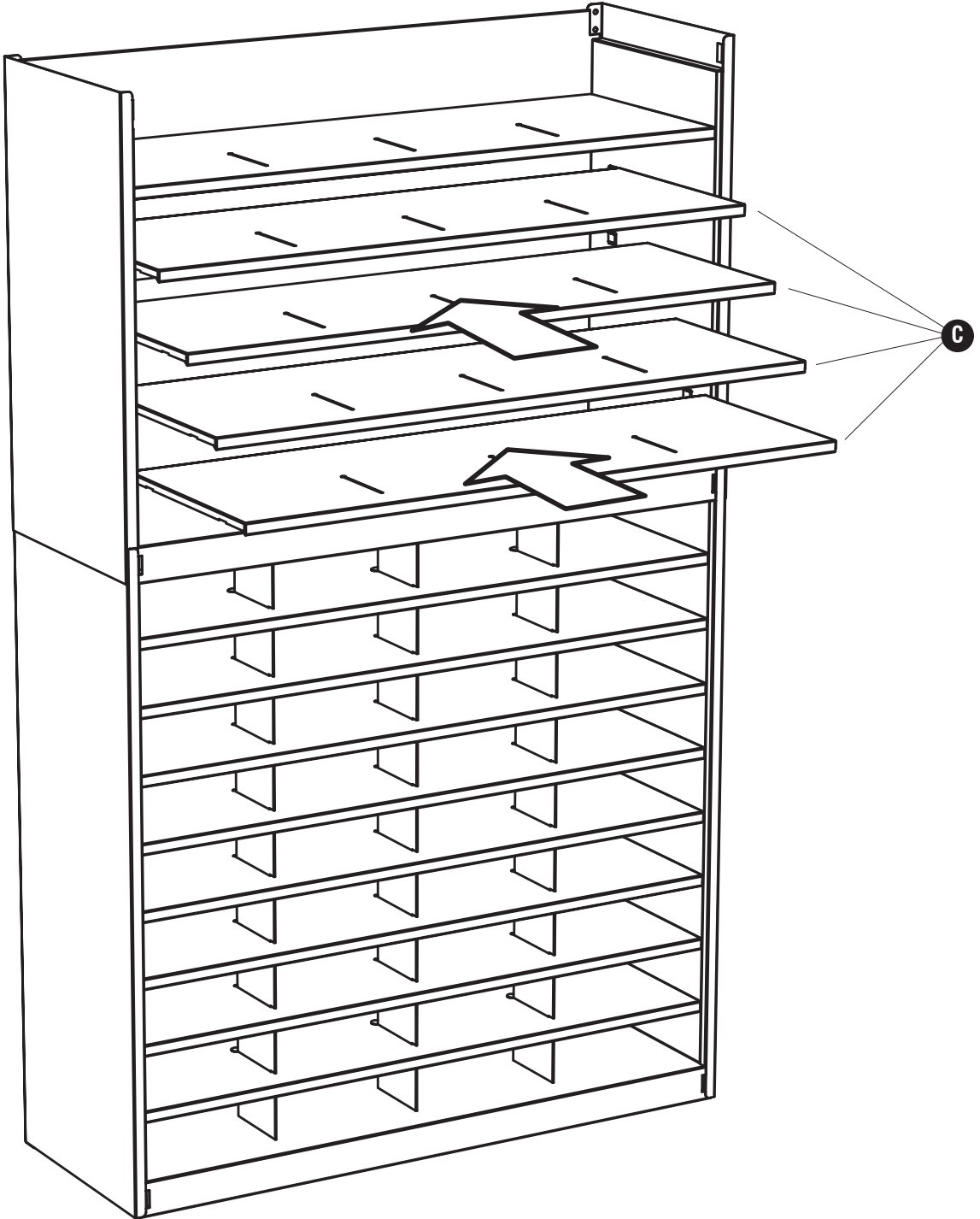

**IMPORTANT: STAMPED PART NUMBER GOES AT TOP OF UNIT**  
*ATTENTION : S'ASSURER QUE LE NUMÉRO DE PIÈCE IMPRIMÉ SE TROUVE VERS LE HAUT DE L'ENSEMBLE.*  
**IMPORTANTE: EL NÚMERO DE PIEZA DEBE QUEDAR EN LA PARTE SUPERIOR DE LA UNIDAD.**

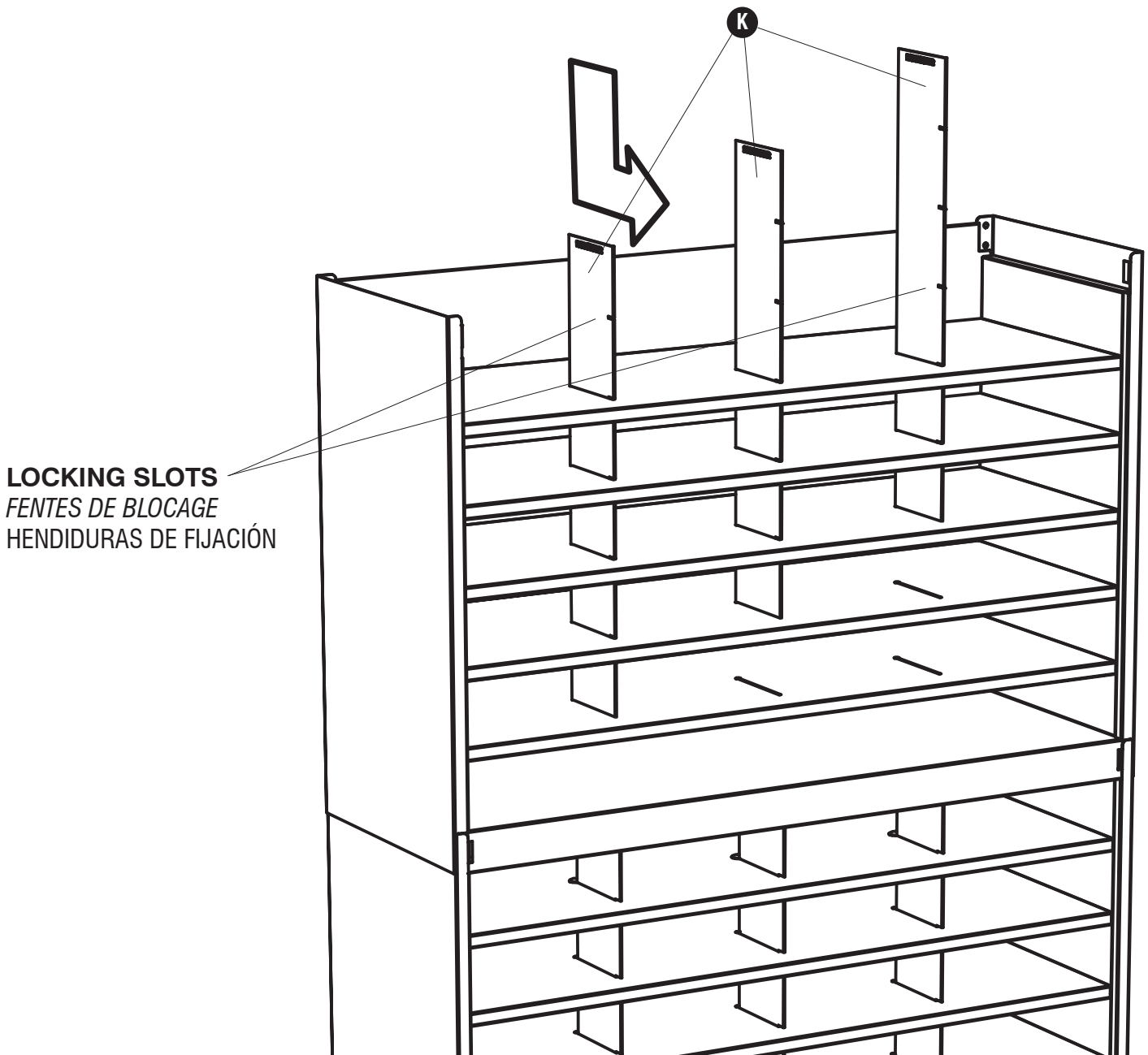

15 **M**  (6)

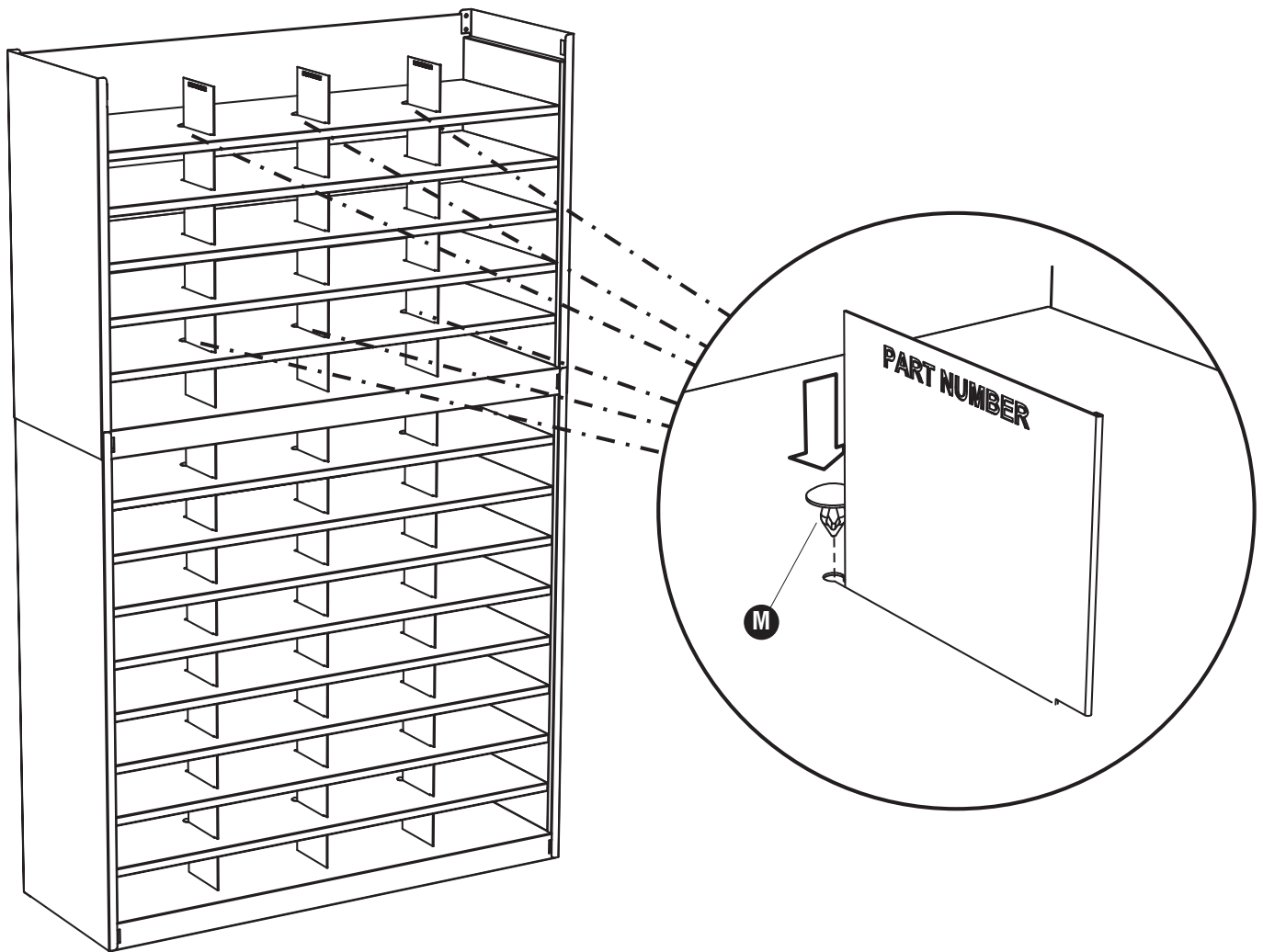

## 16 IMPORTANT: BACK PANEL GOES INSIDE SHELF

ATTENTION : S'ASSURER QUE LE PANNEAU DE FOND SE TROUVE À L'INTÉRIEUR DE L'TABLETTE.

IMPORTANTE: EL PANEL POSTERIOR DEBE QUEDAR EN EL INTERIOR DE LA REPISA.

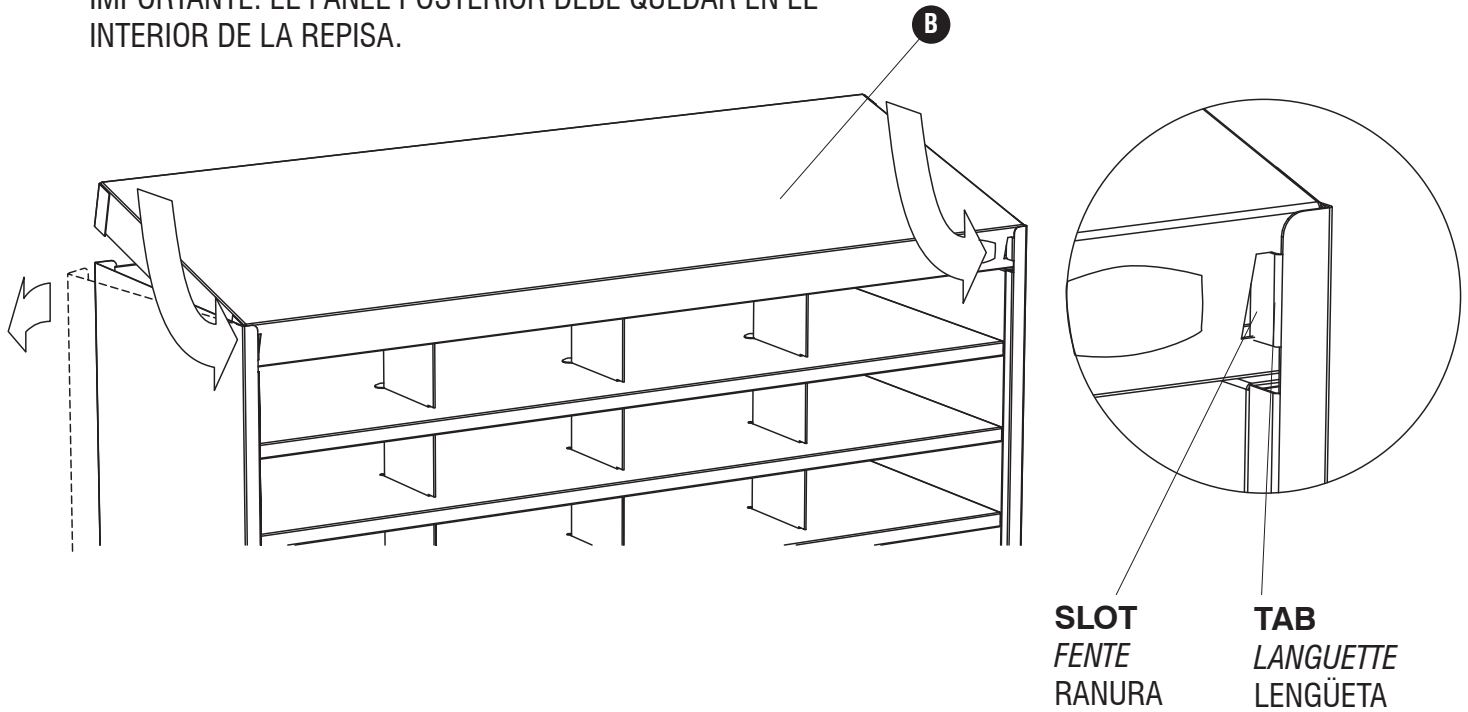

## 17 N (4)

