

ASSEMBLY INSTRUCTIONS
INSTRUCCIONES DE MONTAGE
INSTRUCCIONES DE ENSAMBLAJE

9729

Food Court Receptacle

Réceptacle en bois avec étagère pour plateaux
Contenedor desechado con estante para bandejas

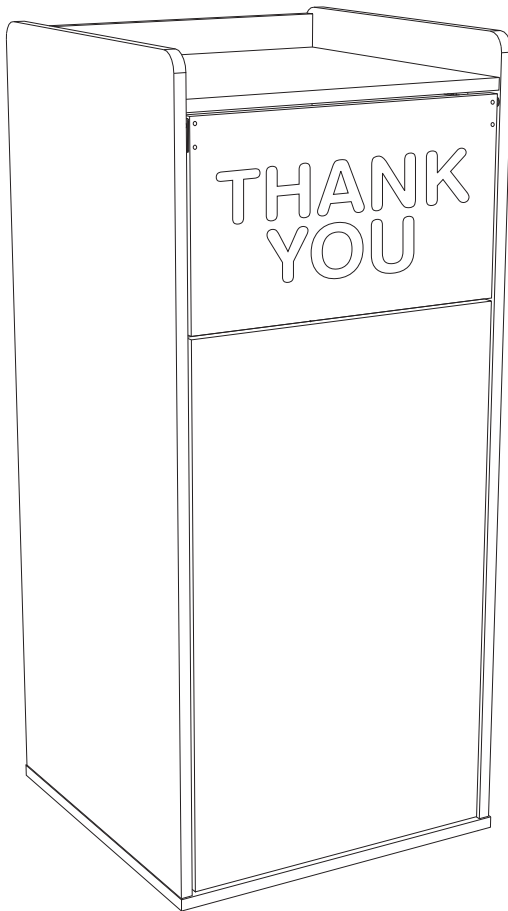

PRODUCT WARRANTY REGISTRATION is available online at: www.safcoproducts.com

• LA GARANTIE DU PRODUIT est
disponible sur l'Internet : www.safcoproducts.com

• LA GARANTÍA DEL PRODUCTO está
disponible en la Internet: www.safcoproducts.com

For questions or concerns, please call **1-800-664-0042**
available Monday-Friday 7:30 AM to 5:00 PM (Central Time) (English-speaking operators)

Si vous avez des questions pour poser ou les préoccupations
pour exprimer, connecter **au 1-800-664-0042**
de 7H30 à 17H00 (Heure centrale) (Opérateurs de langue anglaise)

Si usted tiene preguntas o preocupaciones,
por favor llame **1-800-664-0042**
de 7:30 AM a 5:00 PM (Hora Central) (Operadores que hablan inglés)

TOOLS REQUIRED: Allen Wrench (included); Small Adjustable Wrench; Flat-bladed Screwdriver; Phillips Screwdriver; Hammer or Mallet
OUTILS REQUIS : Clef Allen (inclus); petite clef à molette; tournevis plat à lame; tournevis à pointe cruciforme; marteau ou maillet

HERRAMIENTAS REQUERIDAS: Llave Allen (incluida); llave inglesa pequeña; piso espas destornillador; destornillador Phillips; martillo o mazo
Two People Recommended.

On recommande que l'assemblage soit effectué par deux personnes.

Se recomienda dos personas para el ensamblaje.







Parts List / Liste des Pièces / Lista de Piezas			
Code/ Código	DESCRIPTION / DESCRIPTION / DESCRIPCIÓN	Qty./ Qté/ Cant.	Part No./ N° de Pièce / No. de Pieza
(A)	Back Panel / Panneau arrière / Panel Posterior	1	9729-01§
(B)	Left Side Panel / Panneau latéral gauche / Panel lateral izquierdo	1	9729-03§
(C)	Right Side Panel / Panneau latéral droit / Panel lateral derecho	1	9729-04§
(D)	Bottom Panel with Glides / Panneau inférieur avec glissements / Panel inferior con deslizadores	1	9728-02§
(E)	Top Panel / Panneau supérieur / Panel superior	1	9729-05§
(F)	Small Door (reversible) / Petite porte (réversible) / Puerta pequeña	1	9728-07§
(G)	Large Door / Grande porte / Grande puerta	1	9728-09§

§Note: When corresponding about parts, be sure to state color: Gray (GR) or Medium Oak (MO).

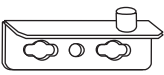
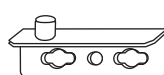
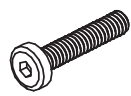
§ Note: Quand correspondre au sujet de parties, soyez sûr d'affirmer la couleur: Gris (GR) ou Chêne Moyen (MO).

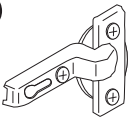
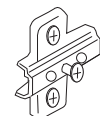
§ Note: Al correspondre sobre las piezas, esté seguro declarar el color: Gris (GR) o Roble Pálido (MO)

Hardware Pack / Paquet Matériel / Paquete Material: 9728-19

<p>H</p>  <p>Left Pivot Hinge Plaque de charnière gauche Plato de la bisagra izquierda Qty. / Qté. / Cant. 1 9728-28</p>	<p>I</p>  <p>Right Pivot Hinge Plaque de charnière droit Plato de la bisagra derecha Qty. / Qté. / Cant. 1 9728-29</p>	<p>J</p>  <p>Button Head Screw Vis avec la bouton tête Tornillo con el cabezal tipo botón Qty. / Qté. / Cant. 4 9728-23</p>	<p>K</p>  <p>Nut Écrou Tuerca Qty. / Qté. / Cant. 4 9728-24</p>	<p>L</p>  <p>Hinge Bushing Bague de charnière Casquillo de la bisagra Qty. / Qté. / Cant. 2 9728-30</p>
<p>M</p>  <p>Hinge Charnière Bisagra Qty. / Qté. / Cant. 2 9728-15</p>	<p>N</p>  <p>Hinge Mount Plate Support de charnière Placa de montaje de la bisagra Qty. / Qté. / Cant. 2 9728-14</p>	<p>O</p>  <p>Bumper Pare-chocs Parachoques Qty. / Qté. / Cant. 1 9728-16</p>	<p>P</p>  <p>Small Bumper Screw Petit vis du pare-chocs Tornillo pequeño para el parachoques Qty. / Qté. / Cant. 1 9728-25</p>	<p>Q</p>  <p>Allen Wrench Clef Allen Llave Allen Qty. / Qté. / Cant. 1 9728-33NC</p>

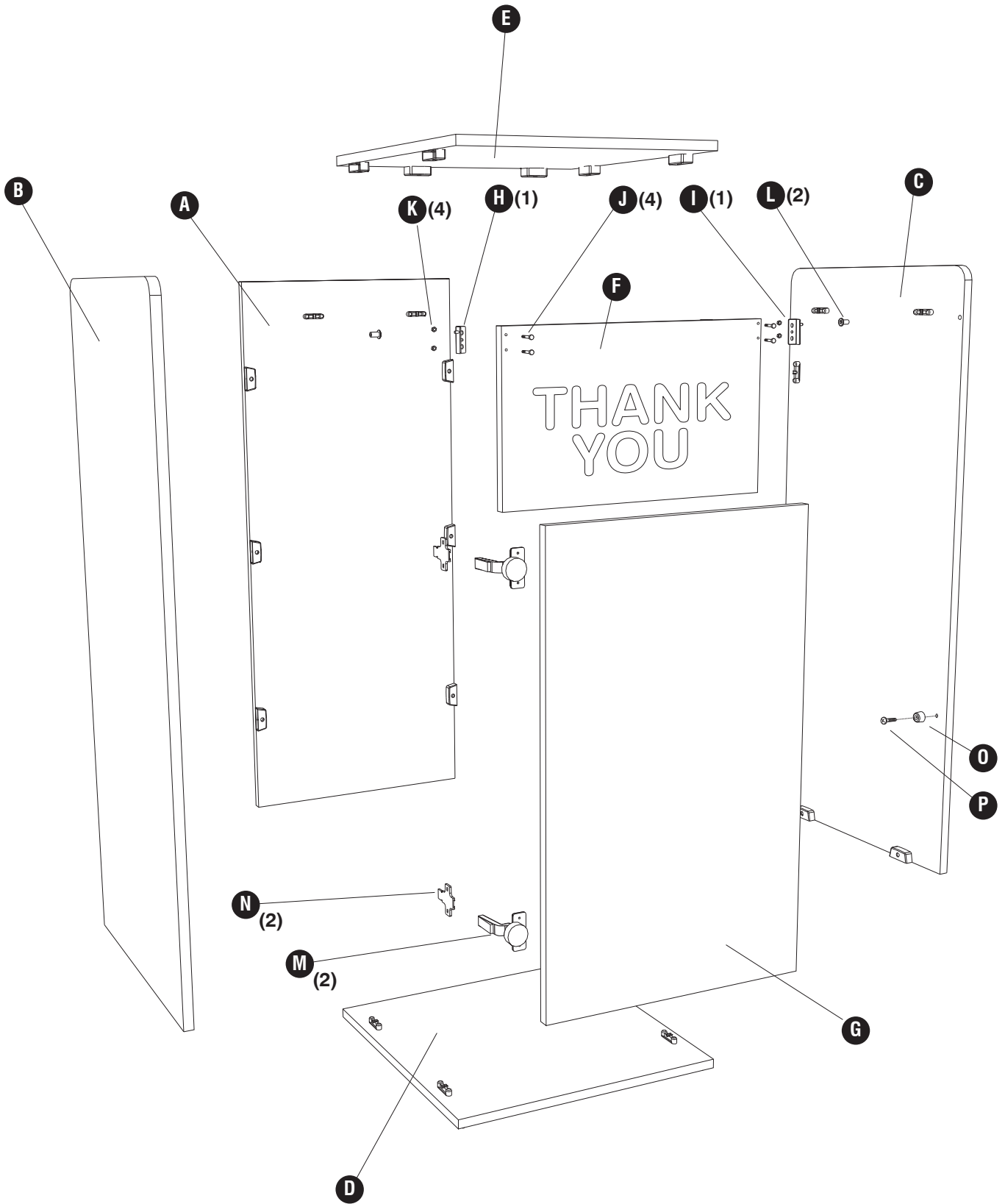

1 **O** (1) **P** (1)

Properly identify the main panels!
Bien identifier les principaux panneaux!
Identificar los paneles principales!

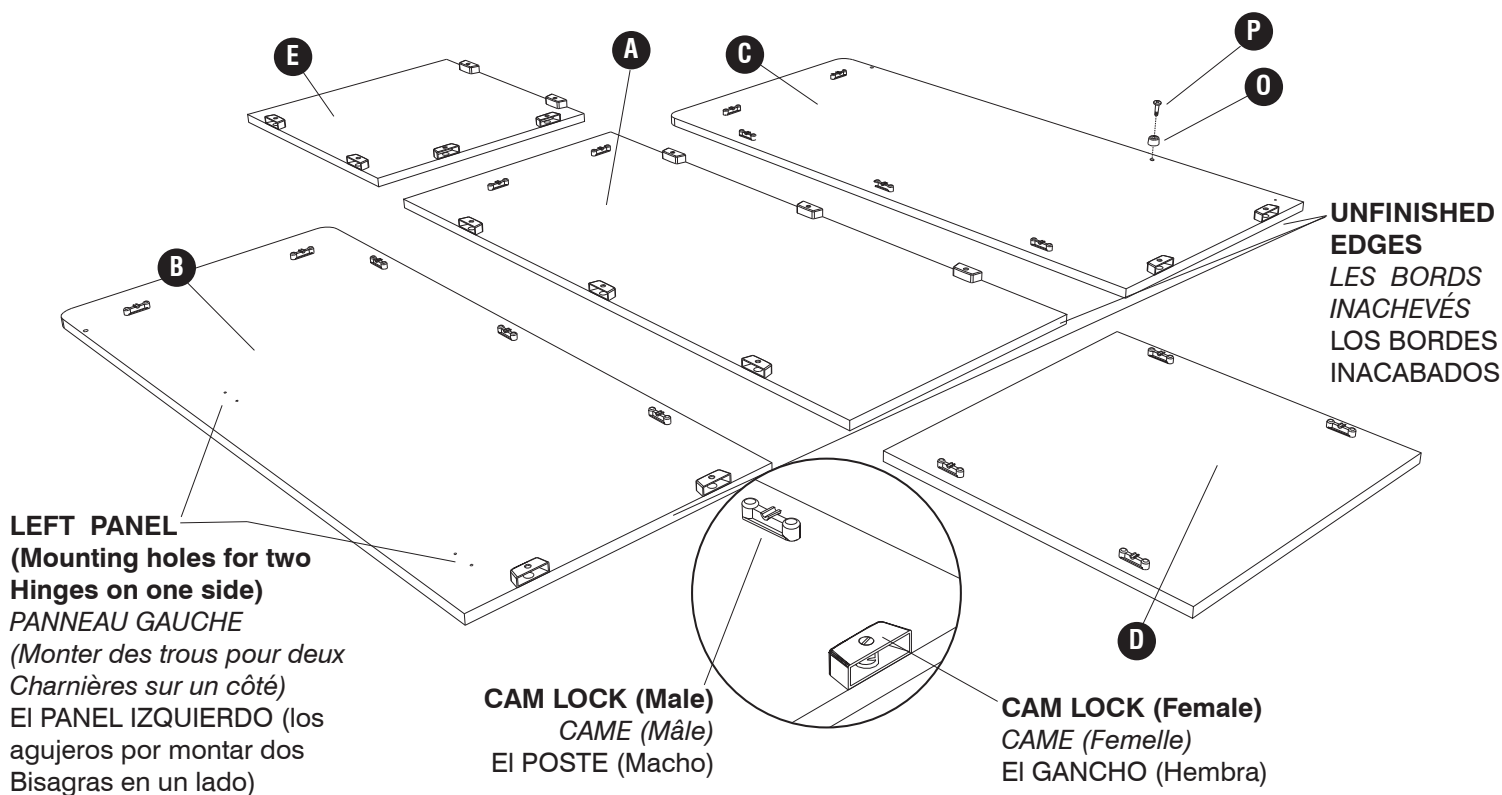

2

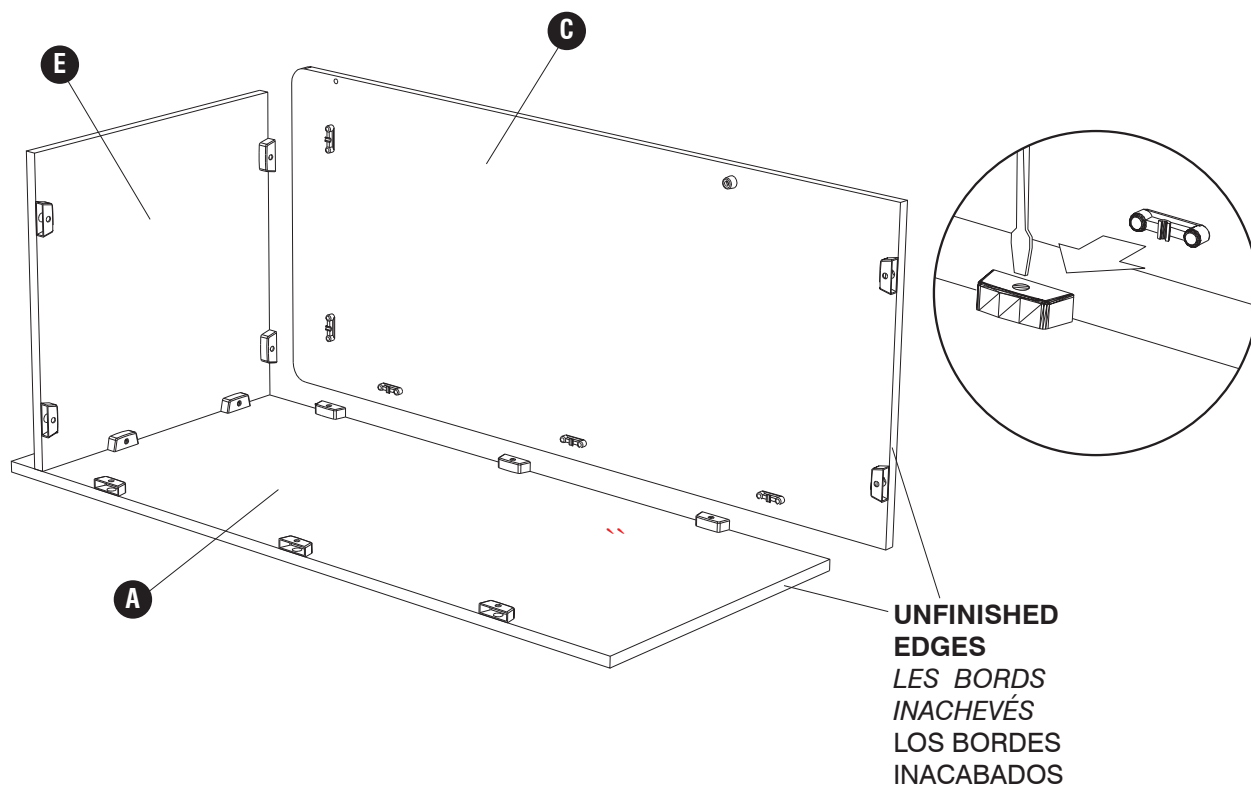

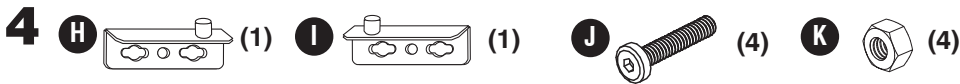
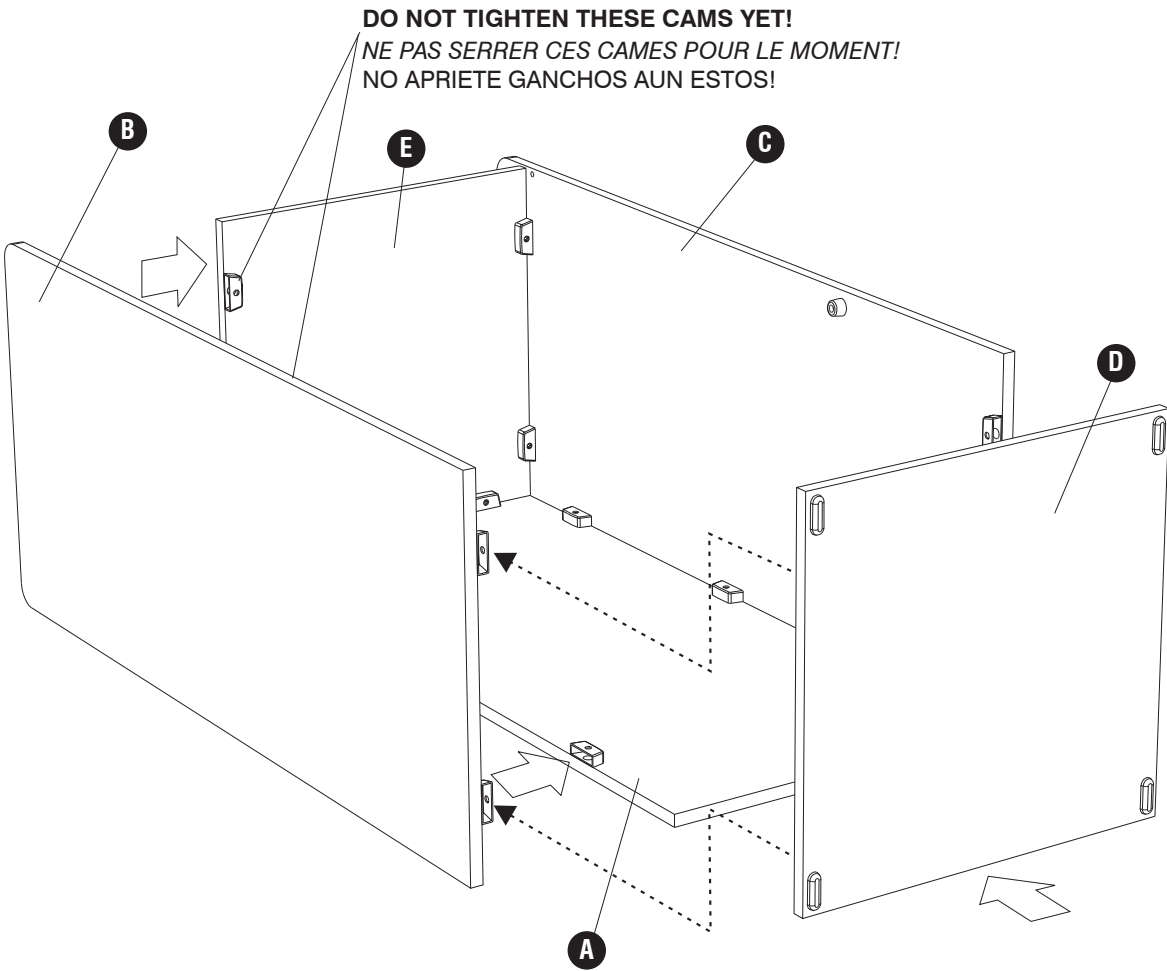
3

Determine which side of the small door will face outward. From the back side fasten the left hinge plate with the peg to the upper left edge of the small door with two button head screws and two nuts (hinge peg should be pointing to the left). Repeat for the right hinge plate, with this hinge peg pointing to the right.

Déterminez quel côté de la petite porte fera face à l'extérieur. Attachez la plaque de la charnière gauche avec le piquet au bord gauche supérieur de l'arrière de la petite porte avec deux vis de la bouton tête et deux écrous (le piquet de la charnière devrait pointer à gauche). Répétez pour la plaque de la charnière droit, avec ce piquet de la charnière qui pointe à droite.

Determine qué lado de la Puerta Pequeña enfrentará afuera. Ate el plato de la bisagra izquierda con la clavija al borde izquierdo superior del trasero de la puerta pequeña con dos tornillos del cabezal tipo botón y dos tuercas (la clavija de la bisagra debe estar apuntando a la izquierda). Repita para el plato de la bisagra derecha, con esta clavija de la bisagra que apunta al derecho.

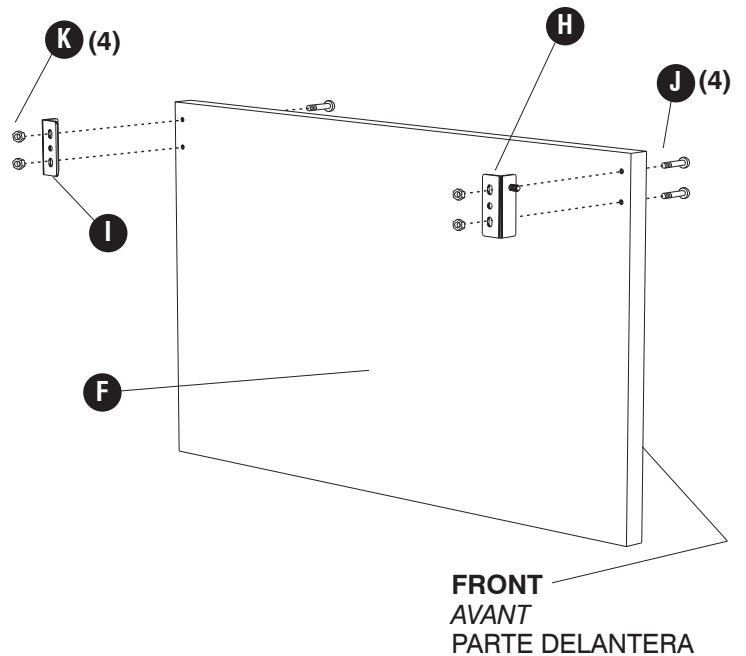

5 **L**  (2)

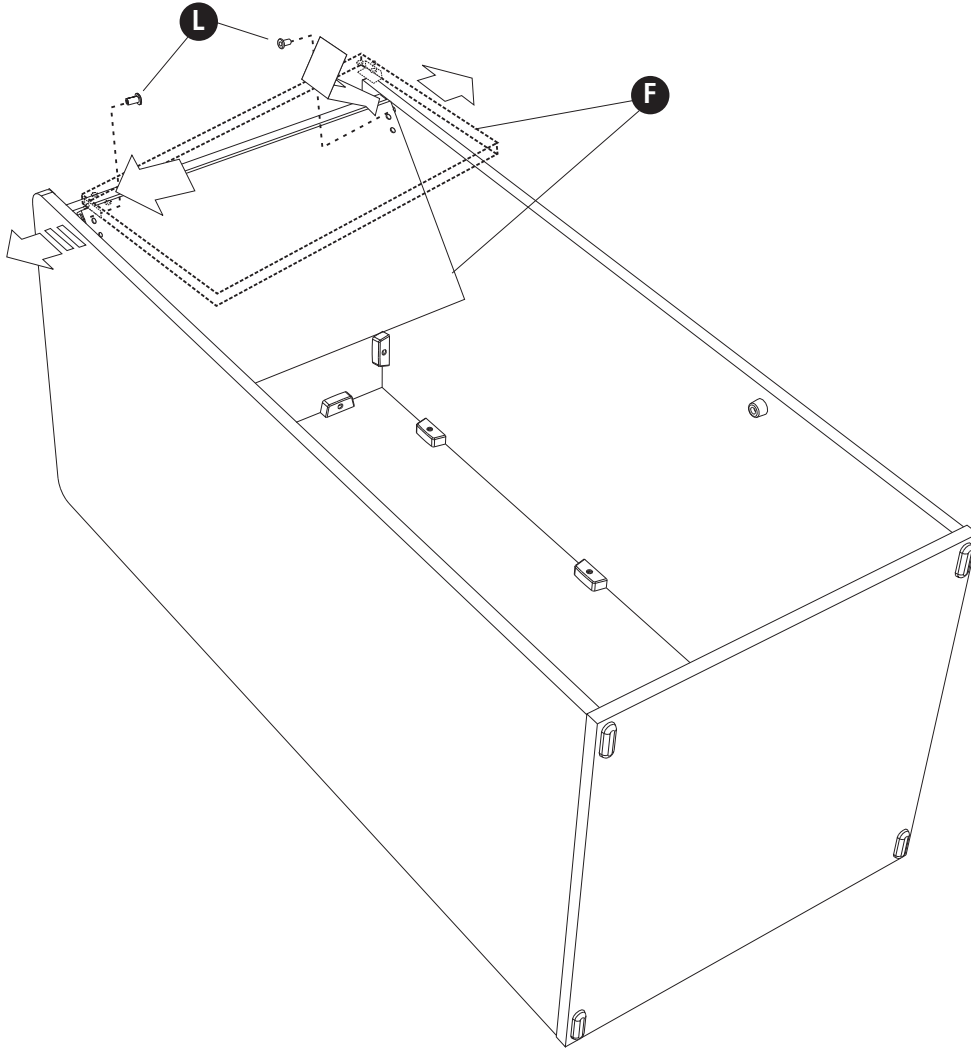

6

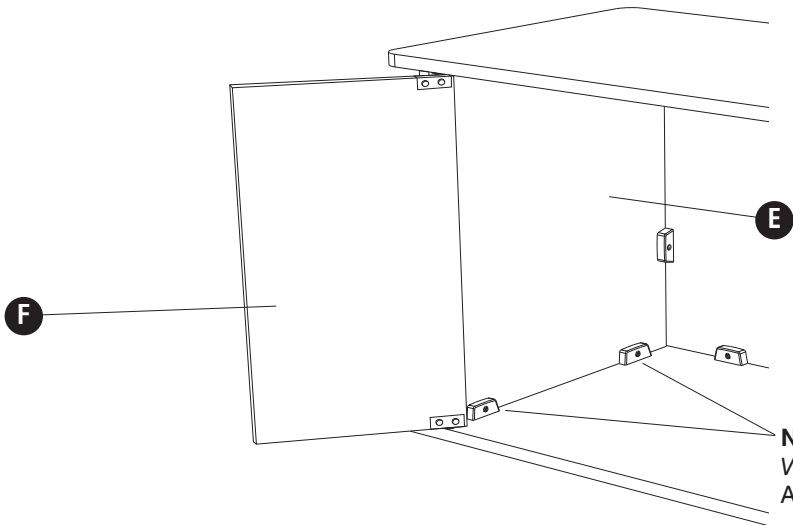

NOW TIGHTEN THESE CAMS!
VOUS SERRER LES CAMES!
AHORA ESTAS APRIETE GANCHOS!

7

M

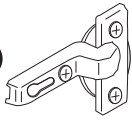

(2)

N

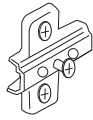

(2)

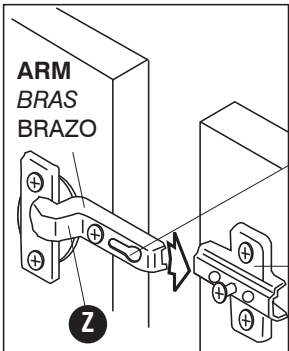
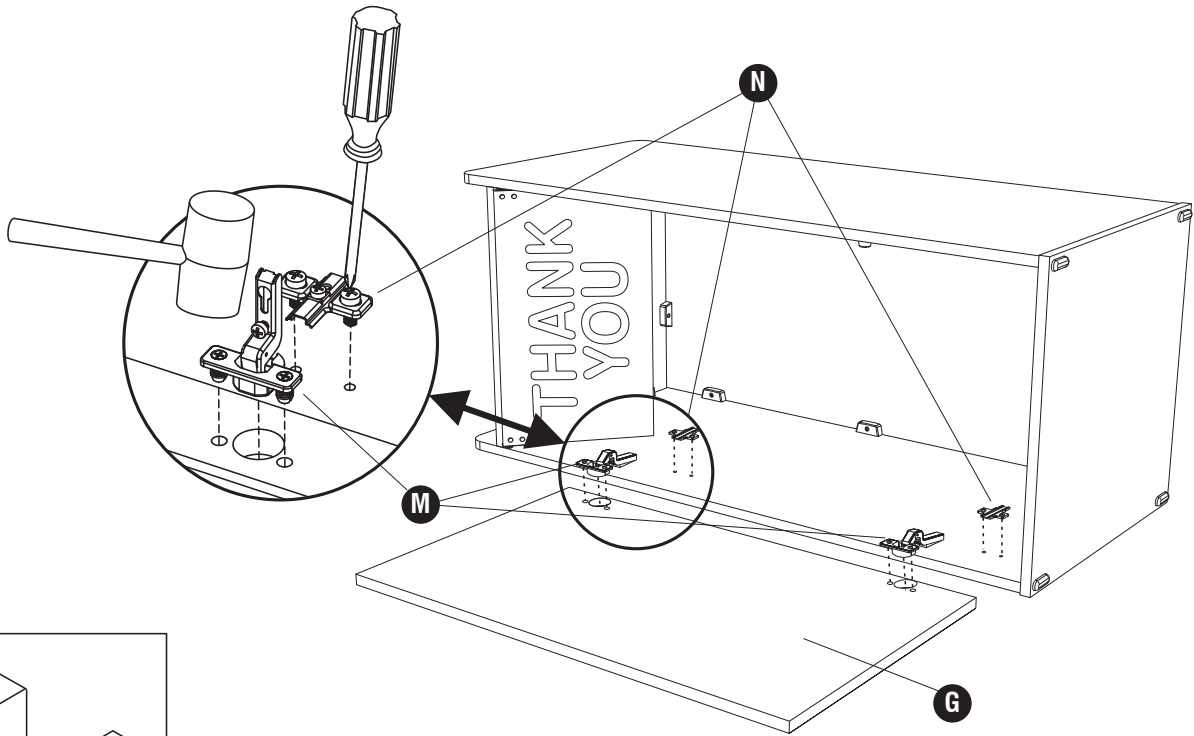

ARM
BRAS
BRAZO

SLOT
FENTE
RANURA

Z

AA

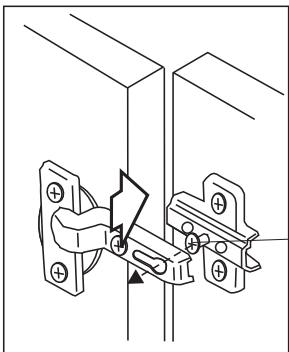

SET SCREW
VIS DE FIXATION
TORNILLO
DE FIJACIÓN

AA

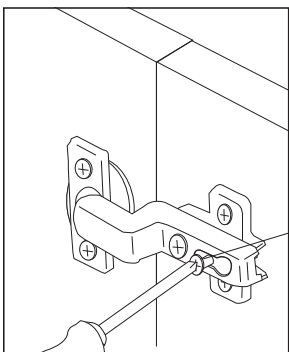

TIGHTEN
SET SCREW
SERRER LA VIS
APRETAR EL TORNILLO
DE FIJACIÓN

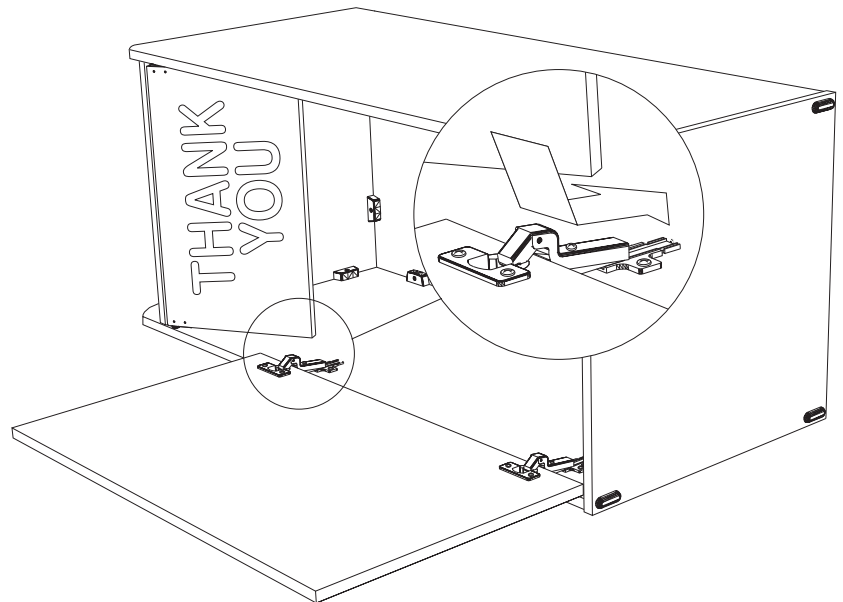

- 8** Adjust the upper door vertically so it does not brush against the lower door panel. Do this by loosening the screws on the hinge plates, and repositioning the panel. Re-fasten all screws. Place the plastic liner (model 9669, sold separately) in the cabinet.

Ajustez la porte supérieure verticalement donc il n'effleure pas le panneau de la porte inférieur. Faites ceci en défaisant les vis sur les plaques de la charnière, et repositionner le panneau. Le ré attache tous les vis. Placez le conteneur plastique (modèle 9669, a vendu séparément) dans l'armoire.

Ajuste la puerta pequeña verticalmente para que no cepilla contra la más bajo puerta. Suelte los tornillos en los platos de la bisagra y ajuste el tablero. Re-ate todos los tornillos. Ponga el contenedor plástico (modelo 9669, vendió separadamente) en el gabinete.

