

# ASSEMBLY INSTRUCTIONS CSII CONFERENCE TABLES

*NOTE: Please count and inspect all pieces before disposing of any carton or packing materials.  
All units consist of 2-3 cartons consisting of the following.*

**TOP CARTON** When ordering components, specific color and/or size information may be required. Contact a Mayline Customer Service Representative. 1-800-822-8037

REF#	QTY.	DESCRIPTION	PART NO. CALL ~-~**	** Denotes Color Code ~-~ Denotes Size
1	1	Top		

**LEG ASSEMBLY CARTON** (Qty. 2, 72"-108", Qty. 3, 120")

REF#	QTY.	DESCRIPTION	PART NO. CALL ~-~**	* Individual Items, Order by part number.
2	1	Leg Assembly		
3	4	Gusset		

**HARDWARE BAG** (Part No. 990043 Qty. 1 per Leg Assembly Carton) \*

REF#	QTY.	DESCRIPTION	PART NO.
E1	8	Screw, M8 x 15/32	--
E2	14	Screw, #10 x 3/4	--
E3	2	Leveler	--

Tools Required for Assembly

Phillips Screw Driver  
Note: A Magnetic or Power Driver may be used to assist in assembly.

1. Begin assembly by attaching four Gussets (3) to Leg Assembly (2) using Screws (E1). See Fig. #1.
2. Install two Levelers (E3) into Leg Assembly (2). See Fig. #1.

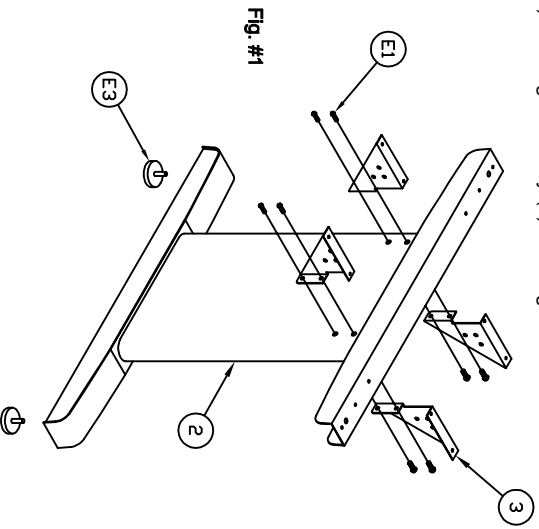

3. Place the Top (1) face down on a clean, flat surface. Attach Leg Assembly onto Top by aligning holes in the Leg Assembly with holes in the Top. See Fig #2

**\*\*NOTE:** Pilot holes are for the leg assembly only. Gusset Mounting use screws w/out pilot hole.\*\*

4. Attach Leg Assembly using Screws (E2). See Fig. #2.
5. Repeat Step 3 and 4 for each Leg Assembly.

