

ASSEMBLY INSTRUCTIONS BISTRO TABLES

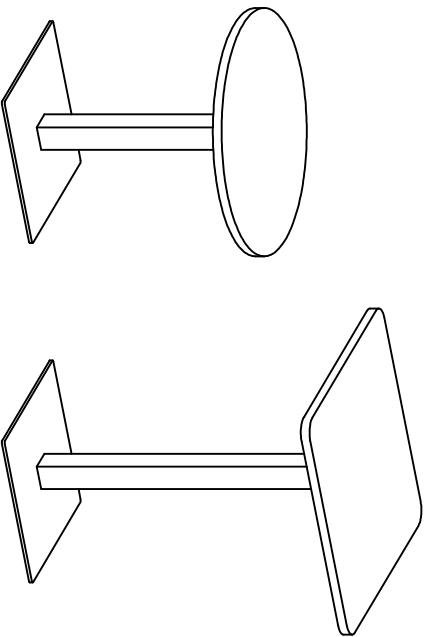

PARTS LIST BISTRO TABLES

When ordering components, specific color and/or size information may be required.
Contact a Mayline Customer Service Representative: 1-800-822-8037

* Individual Items, Order by part number.

** Denotes Color Code

---Denotes Size

NOTE: Please count and inspect all pieces before disposing of any carton or packing materials.

A Reference Letter Part Number Top CALL ~~~**	 1
B Reference Letter Part Number Mounting Plate Reference Letter	 1
C Reference Letter Part Number Column Reference Letter	 1
D Reference Letter Part Number Base	 1

CA100* Hardware Bag	
E Reference Letter Screw M8 x 30mm Reference Letter	 3
F Reference Letter Lock Washer Reference Letter	 3
G Reference Letter Washer Reference Letter	 3
H Reference Letter Screw M8 x 30mm Reference Letter	 3
J Reference Letter M5 x 20mm Reference Letter	 5
K Reference Letter Allen Wrench Reference Letter	 1
L Reference Letter Allen Wrench Reference Letter	 1

IMPORTANT!
Review ALL instructions before beginning assembly. These instructions are provided to avoid problems that may occur from improper assembly or installation. Mayline and/or its distributor are not responsible for failure resulting from improper assembly or installation of this product. Moreover, all warranties are void for failure to follow these assembly instructions.



Mayline Company, LLC
619 N. Commerce, P.O. Box 728
Shelbygan, WI 53082-0728
Toll Free: 1-800-822-8037
FAX: 920-457-7388
On Line: www.mayline.com

(1)

(2)

Assembly:

1. Assemble Mounting Plate (B) to Column (C) using Washer (G) Lockwasher (F) & Screw (E) 3 places as shown in Fig. 1.

2. See Important Tip below as shown in Fig. 2.

3. Assemble Base (D) to Column Assembly using Screw (H) 3 places as shown in Fig. 3.

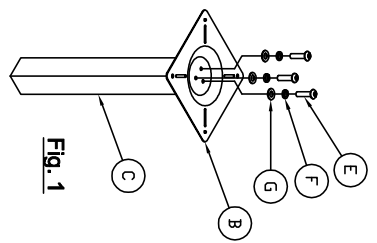

Fig. 1

Important Tip:
Mounting Plate & Base Plate to be parallel with the edge of the top (square top only).

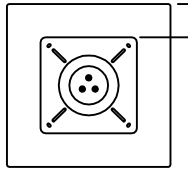

Fig. 2

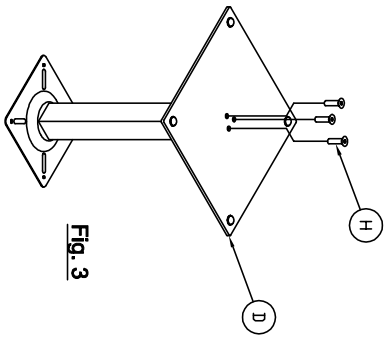

Fig. 3

Assembly for Square and Round Tops

4. Place Top (A) face down on a clean flat surface. Center Base Assembly on Top and attach Base using Screws (J), 4 places as shown in Fig. 4.

Tip: Legs to be parallel with the edge of the top (square top only).

Note:

No pilot holes are necessary. Tops are used across multiple bases having different mounting patterns.

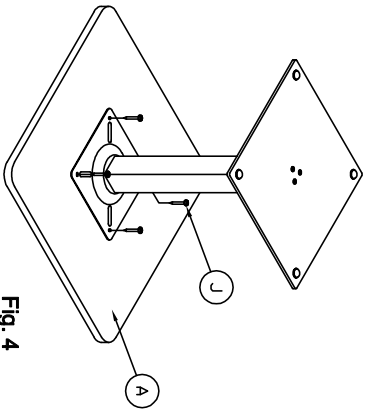

Fig. 4

(3)

Assembly for Rectangular Tops
1. Place Top (A) face down on a clean flat surface. Center Base Assemblies on Top. Dimension "A" to be equal and is determined by centering the base on the width of the top. Dimension "A" to be equal on 3 sides. Attach Base using Screw (J), 4 places per base as shown in Fig. 5.

Important Tip:
Legs to be parallel with the edge of the top (Square & Rectangular top only).

Note:
No pilot holes are necessary. Tops are used across multiple bases having different mounting patterns.

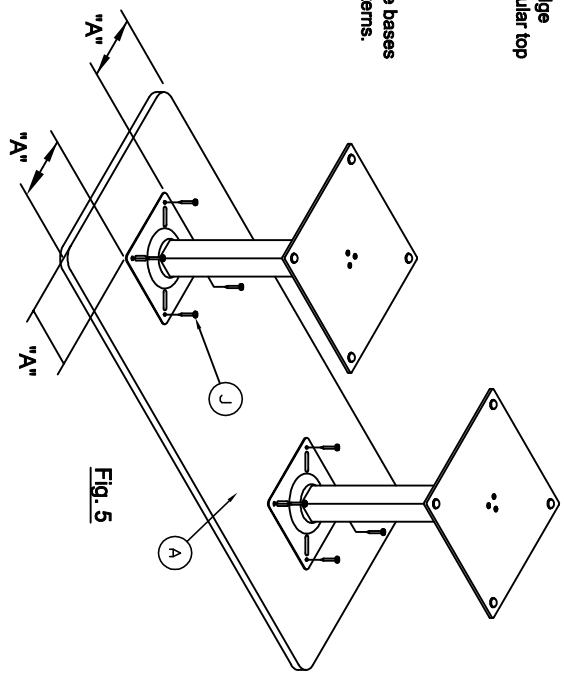

Fig. 5

(4)