

3906 / 3907 / 3908
Whiffle™ Triple Column Mobile Storage Units
Whiffle™ Unités De Stockage Mobiles À Trois Colonnes
Whiffle™ Unidades De Almacenamiento Móvil De Triple Columna

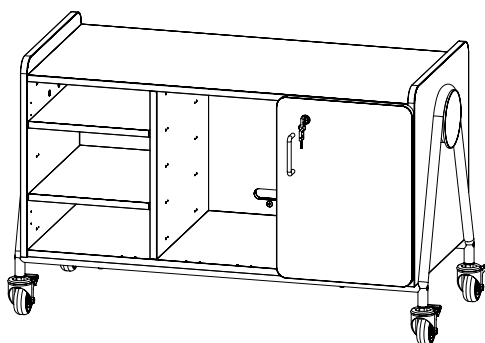

Model 3906 shown
Modèle 3906 montré
Modelo 3906 mostrado

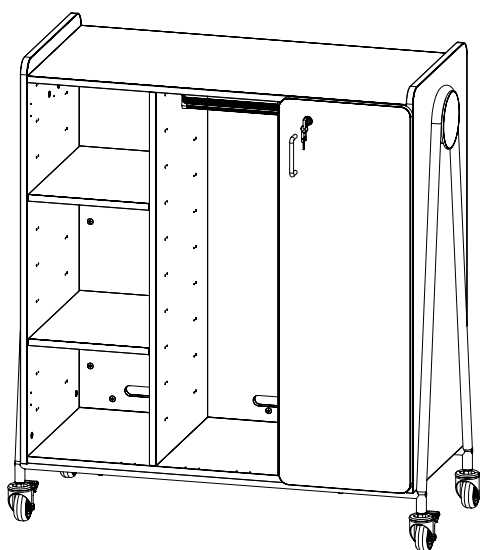

Model 3907 shown
Modèle 3907 montré
Modelo 3907 mostrado

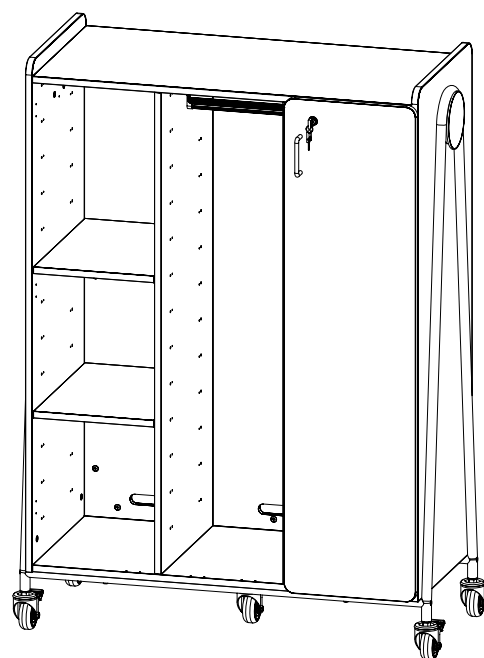

Model 3908 shown
Modèle 3908 montré
Modelo 3908 mostrado

PRODUCT WARRANTY is available online at: www.safcoproducts.com

• LA GARANTIE DU PRODUIT est disponible sur l'Internet : www.safcoproducts.com

• LA GARANTÍA DEL PRODUCTO está disponible en la Internet: www.safcoproducts.com

For questions or concerns, please call **1-888-971-6225**
available Monday-Friday 7:30 AM to 5:00 PM (Central Time) (English-speaking operators)

Si vous avez des questions pour poser ou les préoccupations pour exprimer, connecter au **1-888-971-6225** de 7H30 à 17H00 (Heure centrale) (Opérateurs de langue anglaise)

Si usted tiene preguntas o preocupaciones, por favor llame **1-888-971-6225** de 7:30 AM a 5:00 PM (Hora Central) (Operadores que hablan inglés)

TOOLS REQUIRED: Phillips Screwdriver, 4mm Hex Key, Drill
OUTILS REQUIS : Tournevis À Pointe Cruciforme, Clé hexagonale de 4mm, Percer
HERRAMIENTAS REQUERIDAS: Destornillador Phillips, Llave hexagonal de 4mm, Perforar

PARTS LIST / LISTE DES PIÈCES / LISTA DE PIEZAS

CODE / CODIGO	DESCRIPTION / DESCRIPTION / DESCRIPCIÓN	QTY. / QUANTITÉ / CANTIDAD	PART NO. / N° DE PIÈCE / NO. DE PIEZA
(A)	Top Panel / Panneau du haut / Panel superior For 3906 / 3907 / 3908	1	420000097
(B)	Bottom Panel / Panneau du bas / Panel inferior For 3906 / 3907 / 3908	1	420000100
(C)	Back Panel / Panneau arrière / Panel posterior For 3906 For 3907 For 3908	1 1 1	420000092 420000093 420000094
(D)	Left Side Panel / Panneau latéral gauche / Panel lateral izquierdo For 3906 For 3907 For 3908	1 1 1	420000080\$ 420000081\$ 420000082\$
(E)	Right Side Panel / Panneau latéral gauche / Panel lateral izquierdo For 3906 For 3907 For 3908	1 1 1	420000113\$ 420000114\$ 420000115\$
(F)	Divider / Cloison / Tabique For 3906 For 3907 For 3908	2 2 2	420000101 420000102 420000103
(G)	Side Frame / Cadre latéral / Marco lateral For 3906 For 3907 For 3908	2 2 2	430000064 430000065 430000066
(H)	Bottom Frame / Cadre inférieur / Marco inferior For 3906 / 3907 For 3908	2 1	410000148 410000171
(I)	Button / Bouton / Botón	2	410000149\$
(J)	Left Door (NOT SHOWN) / Porte gauche (PAS MONTRÉ) / Puerta izquierda (NO MOSTRADA) Double Door For 3906 Double Door For 3907 Double Door For 3908 Triple Door For 3906 Triple Door For 3907 Triple Door For 3908	1 1 1 1 1 1	435000132 435000133 435000134 435000135 435000136 435000137
(K)	Right Door / Porte droite / Puerta derecha Double Door For 3906 Double Door For 3907 Double Door For 3908 Triple Door For 3906 Triple Door For 3907 Triple Door For 3908	1 1 1 1 1 1	435000124 435000125 435000126 435000127 435000128 435000129
(L)	Locking Caster / Verrouillage de la roulette / Rueda de bloqueo	2	970000062
(M)	Non-locking Caster / Roulette non verrouillable / Rueda sin bloqueo For 3906 / 3907 For 3908	2 3	970000057 970000057

\$Note: When talking about parts, state color:

Electric Blue (EBU), Green (GRN), Gray (GRY), Orange, (ORG), Red (RED), and Spectrum Blue (SBU)

\$Noter: Lorsque vous parlez de pièces, indiquez la couleur:

Bleu électrique (EBU), Vert (GRN), Gris (GRY), Orange, (ORG), Rouge (RED) et Bleu spectre (SBU)

\$Nota: Al hablar de partes, indique el color:

Azul eléctrico (EBU), Verde (GRN), Gris (GRY), Naranja, (ORG), Rojo (RED) y Azul espectro (SBU)

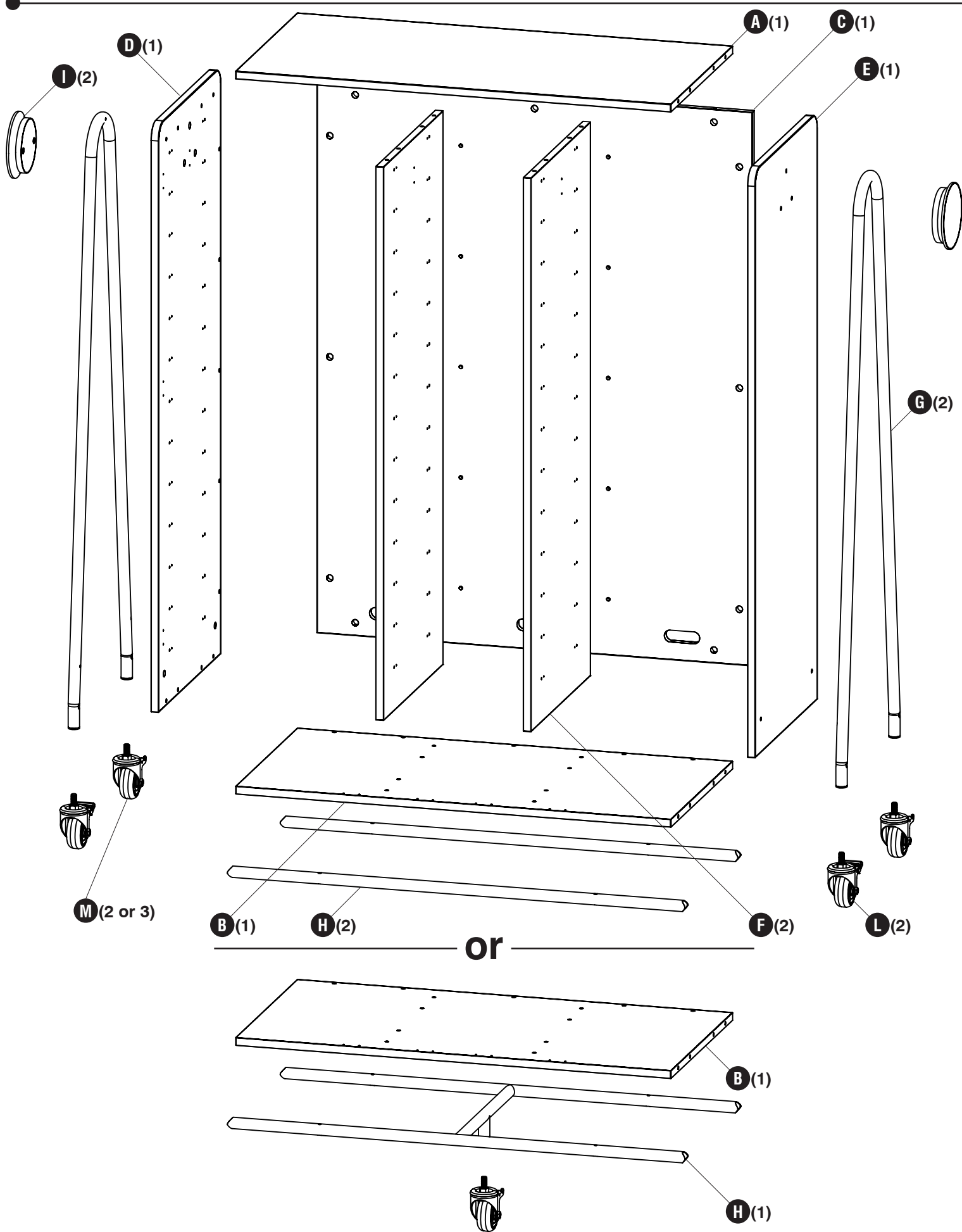

TOOLS REQUIRED: Phillips Screwdriver, 4mm Hex Key, Drill
OUTILS REQUIS : Tournevis À Pointe Cruciforme, Clé hexagonale de 4mm, Percer
HERRAMIENTAS REQUERIDAS: Destornillador Phillips, Llave hexagonal de 4mm, Perforar

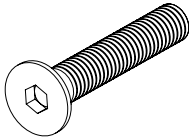
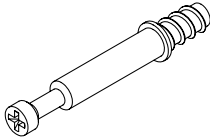
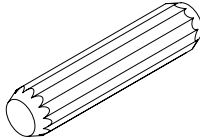
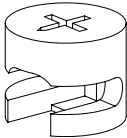
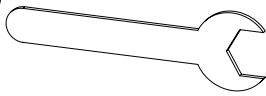
Hardware Pack / Paquet Matériel / Paquete Material: 90000301		
N  M6 X 35mm Screw <i>Vis M6 X 35mm</i> Tornillo M6 X 35mm Qty. / Qté. / Cant. 3906: 14 Qty. / Qté. / Cant. 3907: 18 Qty. / Qté. / Cant. 3908: 18 905000006	O  Cam Pin Screw <i>Vis à came</i> Tornillo de pasador de leva Qty. / Qté. / Cant. 3906: 30 Qty. / Qté. / Cant. 3907: 34 Qty. / Qté. / Cant. 3908: 34 920000306	P  Wood Dowel <i>Goujon en bois</i> Taco de madera Qty. / Qté. / Cant. 3906: 24 Qty. / Qté. / Cant. 3907: 28 Qty. / Qté. / Cant. 3908: 28 920000049
Q  Cam <i>Came</i> Leva Qty. / Qté. / Cant. 3906: 30 Qty. / Qté. / Cant. 3907: 34 Qty. / Qté. / Cant. 3908: 34 920000310	R  19mm Open Ended Wrench <i>Clé ouverte de 19mm</i> Llave de abierto de 19mm Qty. / Qté. / Cant. 3906: 1 Qty. / Qté. / Cant. 3907: 1 Qty. / Qté. / Cant. 3908: 1 920000467	

Note: Cam stickers, Maple (MPL), included with Whiffle™ Mobile Storage Kit.

Noter: Autocollants à came, érable (MPL), inclus avec le kit de rangement mobile Whiffle™.

Nota: Pegatinas de leva, arce (MPL), incluidas con el kit de almacenamiento móvil Whiffle™.

Note: Colored cam stickers, 920000469, available for order:

Electric Blue (EBU), Green (GRN), Gray (GRY), Orange, (ORG), Red (RED), and Spectrum Blue (SBU)

Noter: Autocollants à cames colorés, 920000469, disponibles à la commande:

Bleu électrique (EBU), Vert (GRN), Gris (GRY), Orange, (ORG), Rouge (RED) et Bleu spectre (SBU)

Nota: Etiquetas adhesivas de color, 920000469, disponibles para pedido:

Azul eléctrico (EBU), Verde (GRN), Gris (GRY), Naranja, (ORG), Rojo (RED) y Azul espectro (SBU)

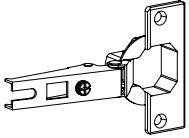
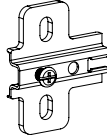
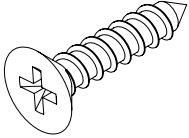
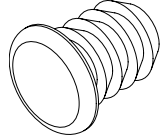
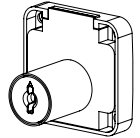
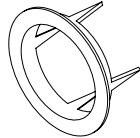
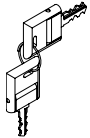
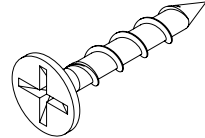
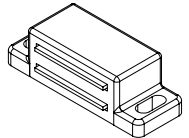
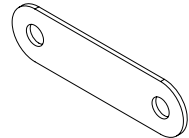
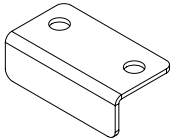
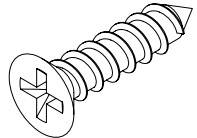
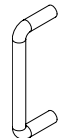
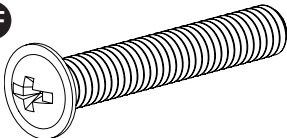

Optional Door Hardware Pack / Pack de quincallerie de porte en option / Paquete opcional de herrajes para puertas:

900000294

<p>S</p>  <p>Door Wing for Hinge Aile de porte pour charnière Ala de puerta para bisagra</p> <p>Qty. / Qté. / Cant. 3906: 2 Qty. / Qté. / Cant. 3907: 2 Qty. / Qté. / Cant. 3908: 3 920000456</p>	<p>T</p>  <p>Frame Wing for Hinge Aile de cadre pour charnière Marco de ala para bisagra</p> <p>Qty. / Qté. / Cant. 3906: 2 Qty. / Qté. / Cant. 3907: 2 Qty. / Qté. / Cant. 3908: 3 920000457</p>	<p>U</p>  <p>M4 X 16mm Screw Vis M4 X 16mm Tornillo M4 X 16mm</p> <p>Qty. / Qté. / Cant. 3906: 8 Qty. / Qté. / Cant. 3907: 8 Qty. / Qté. / Cant. 3908: 12 905000303</p>	<p>V</p>  <p>Door Bumper (PRE-INSTALLED) Porte pare-chocs (PRE-INSTALLÉ) Tope de puerta (PRE-INSTALADO)</p> <p>Qty. / Qté. / Cant. 3906: 2 Qty. / Qté. / Cant. 3907: 2 Qty. / Qté. / Cant. 3908: 2 920000463</p>
<p>W</p>  <p>Door Lock Serrure de porte Cerradura de la puerta</p> <p>Qty. / Qté. / Cant. 3906: 1 Qty. / Qté. / Cant. 3907: 1 Qty. / Qté. / Cant. 3908: 1 920000458</p>	<p>X</p>  <p>Door Lock Trim Garniture de serrure de porte Ajuste de la cerradura de la puerta</p> <p>Qty. / Qté. / Cant. 3906: 1 Qty. / Qté. / Cant. 3907: 1 Qty. / Qté. / Cant. 3908: 1 920000459</p>	<p>Y</p>  <p>Keys Clés Llaves</p> <p>Qty. / Qté. / Cant. 3906: 1 Qty. / Qté. / Cant. 3907: 1 Qty. / Qté. / Cant. 3908: 1 920000466</p>	<p>Z</p>  <p>#10 X 20mm Screw Vis #10 X 20mm Tornillo #10 X 20mm</p> <p>Qty. / Qté. / Cant. 3906: 4 Qty. / Qté. / Cant. 3907: 4 Qty. / Qté. / Cant. 3908: 4 905000424</p>
<p>AA</p>  <p>Magnetic Latch Loquet magnétique Cierre magnético</p> <p>Qty. / Qté. / Cant. 3906: 1 Qty. / Qté. / Cant. 3907: 1 Qty. / Qté. / Cant. 3908: 1 435000170</p>	<p>BB</p>  <p>Magnetic Latch Bracket Support de loquet magnétique Soporte de cierre magnético</p> <p>Qty. / Qté. / Cant. 3906: 1 Qty. / Qté. / Cant. 3907: 1 Qty. / Qté. / Cant. 3908: 1 435000171</p>	<p>CC</p>  <p>L-Bracket Lock Plate Plaque de verrouillage de L-support Placa de bloqueo de L-soporte</p> <p>Qty. / Qté. / Cant. 3906: 1 Qty. / Qté. / Cant. 3907: 1 Qty. / Qté. / Cant. 3908: 1 920000414</p>	<p>DD</p>  <p>M4 X 14mm Screw Vis M4 X 14mm Tornillo M4 X 14mm</p> <p>Qty. / Qté. / Cant. 3906: 6 Qty. / Qté. / Cant. 3907: 6 Qty. / Qté. / Cant. 3908: 6 905000257</p>
<p>EE</p>  <p>Door Handle Poignée de porte Manija de la puerta</p> <p>Qty. / Qté. / Cant. 3906: 1 Qty. / Qté. / Cant. 3907: 1 Qty. / Qté. / Cant. 3908: 1 925000012</p>	<p>FF</p>  <p>M4 X 25mm Screw Vis M4 X 25mm Tornillo M4 X 25mm</p> <p>Qty. / Qté. / Cant. 3906: 2 Qty. / Qté. / Cant. 3907: 2 Qty. / Qté. / Cant. 3908: 2 905000423</p>		

Optional Accessory Pack / Pack d'accessoires en option / Paquete de accesorios opcional:

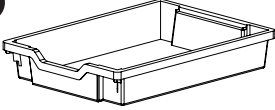
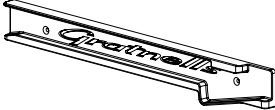
3911CL

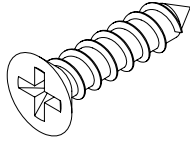
<p>GG</p>  <p>3" H Clear Tote 3" H fourre-tout clair 3" H claro totalizador</p> <p>Qty. / Qté. / Cant. 5 435000159</p>	<p>HH</p>  <p>Right-Handed Tote Glide Fourre-tout glisser main droitier Totalizador de deslizamiento diestro</p> <p>Qty. / Qté. / Cant. 5 435000164</p>	<p>II</p>  <p>Left-Handed Tote Glide Fourre-tout glisser main gaucher Totalizador de deslizamiento zurdo</p> <p>Qty. / Qté. / Cant. 5 435000165</p>	<p>DD</p>  <p>M4 X 14mm Screw Vis M4 X 14mm Tornillo M4 X 14mm</p> <p>Qty. / Qté. / Cant. 20 905000257</p>
---	--	---	---

Optional Accessory Pack / Pack d'accessoires en option / Paquete de accesorios opcional:

3912CL

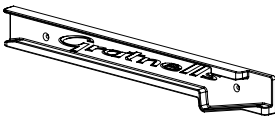
<p>JJ</p>  <p>6" H Clear Tote 6" H fourre-tout clair 6" H claro totalizador</p> <p>Qty. / Qté. / Cant. 4 435000160</p>	<p>HH</p>  <p>Right-Handed Tote Glide Fourre-tout glisser main droitier Totalizador de deslizamiento diestro</p> <p>Qty. / Qté. / Cant. 5 435000164</p>	<p>II</p>  <p>Left-Handed Tote Glide Fourre-tout glisser main gaucher Totalizador de deslizamiento zurdo</p> <p>Qty. / Qté. / Cant. 5 435000165</p>	<p>DD</p>  <p>M4 X 14mm Screw Vis M4 X 14mm Tornillo M4 X 14mm</p> <p>Qty. / Qté. / Cant. 16 905000257</p>
---	--	---	---

Optional Accessory Pack / Pack d'accessoires en option / Paquete de accesorios opcional:

3913CL

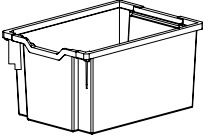
<p>KK</p>  <p>9" H Clear Tote 9" H fourre-tout clair 9" H claro totalizador</p> <p>Qty. / Qté. / Cant. 3 435000161</p>	<p>HH</p>  <p>Right-Handed Tote Glide Fourre-tout glisser main droitier Totalizador de deslizamiento diestro</p> <p>Qty. / Qté. / Cant. 5 435000164</p>	<p>II</p>  <p>Left-Handed Tote Glide Fourre-tout glisser main gaucher Totalizador de deslizamiento zurdo</p> <p>Qty. / Qté. / Cant. 5 435000165</p>	<p>DD</p>  <p>M4 X 14mm Screw Vis M4 X 14mm Tornillo M4 X 14mm</p> <p>Qty. / Qté. / Cant. 12 905000257</p>
---	--	---	---

Optional Accessory Pack / Pack d'accessoires en option / Paquete de accesorios opcional:

3914CL

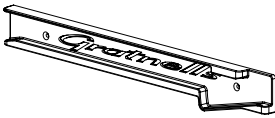
<p>LL</p>  <p>12" H Clear Tote 12" H fourre-tout clair 12" H claro totalizador</p> <p>Qty. / Qté. / Cant. 2 435000162</p>	<p>HH</p>  <p>Right-Handed Tote Glide Fourre-tout glisser main droitier Totalizador de deslizamiento diestro</p> <p>Qty. / Qté. / Cant. 5 435000164</p>	<p>II</p>  <p>Left-Handed Tote Glide Fourre-tout glisser main gaucher Totalizador de deslizamiento zurdo</p> <p>Qty. / Qté. / Cant. 5 435000165</p>	<p>DD</p>  <p>M4 X 14mm Screw Vis M4 X 14mm Tornillo M4 X 14mm</p> <p>Qty. / Qté. / Cant. 8 905000257</p>
--	--	---	--

Optional Accessory Pack / Pack d'accessoires en option / Paquete de accesorios opcional: 3917		
		
MM Wardrobe Bar Support <i>Support de garde-robe</i> Soporte de barra de armario	NN Wardrobe Bar <i>garde-robe bar</i> Barra de armario	DD M4 X 14mm Screw <i>Vis M4 X 14mm</i> Tornillo M4 X 14mm
Qty. / Qté. / Cant. 2 470000340	Qty. / Qté. / Cant. 1 470000338	Qty. / Qté. / Cant. 4 905000257

**Optional Accessory Pack /
Pack d'accessoires en option /
Paquete de accesorios opcional:
3915MA**

OO



Single Shelf
Tablette simple
Estante individual

Qty. / Qté. / Cant. 2
435000154

**Optional Accessory Pack /
Pack d'accessoires en option /
Paquete de accesorios opcional:
3916MA**

PP

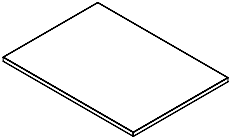

Double Shelf
Tablette double
Estante doble

Qty. / Qté. / Cant. 2
435000155

**Optional Accessory Pack /
Pack d'accessoires en option /
Paquete de accesorios opcional:
900000295**

QQ

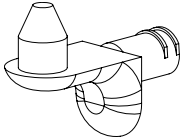

Shelf Pin
Goupille d'étagère
Estante pin

Qty. / Qté. / Cant. 9
920000468

**Optional Accessory Pack /
Pack d'accessoires en option /
Paquete de accesorios opcional:
3918**

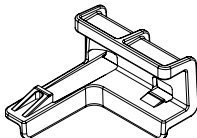
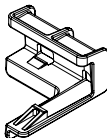
	
RR Left-Handed Tote Stop Clip <i>Clip de butée pour gaucher</i> Clip de tope para zurdos	SS Right-Handed Tote Stop Clip <i>Clip d'arrêt pour fourre-tout droitier</i> Clip de tope de mano derecha
Qty. / Qté. / Cant. 5 435000166	Qty. / Qté. / Cant. 5 435000165

1 For Model 3908
Pour le modèle 3908
Para el modelo 3908

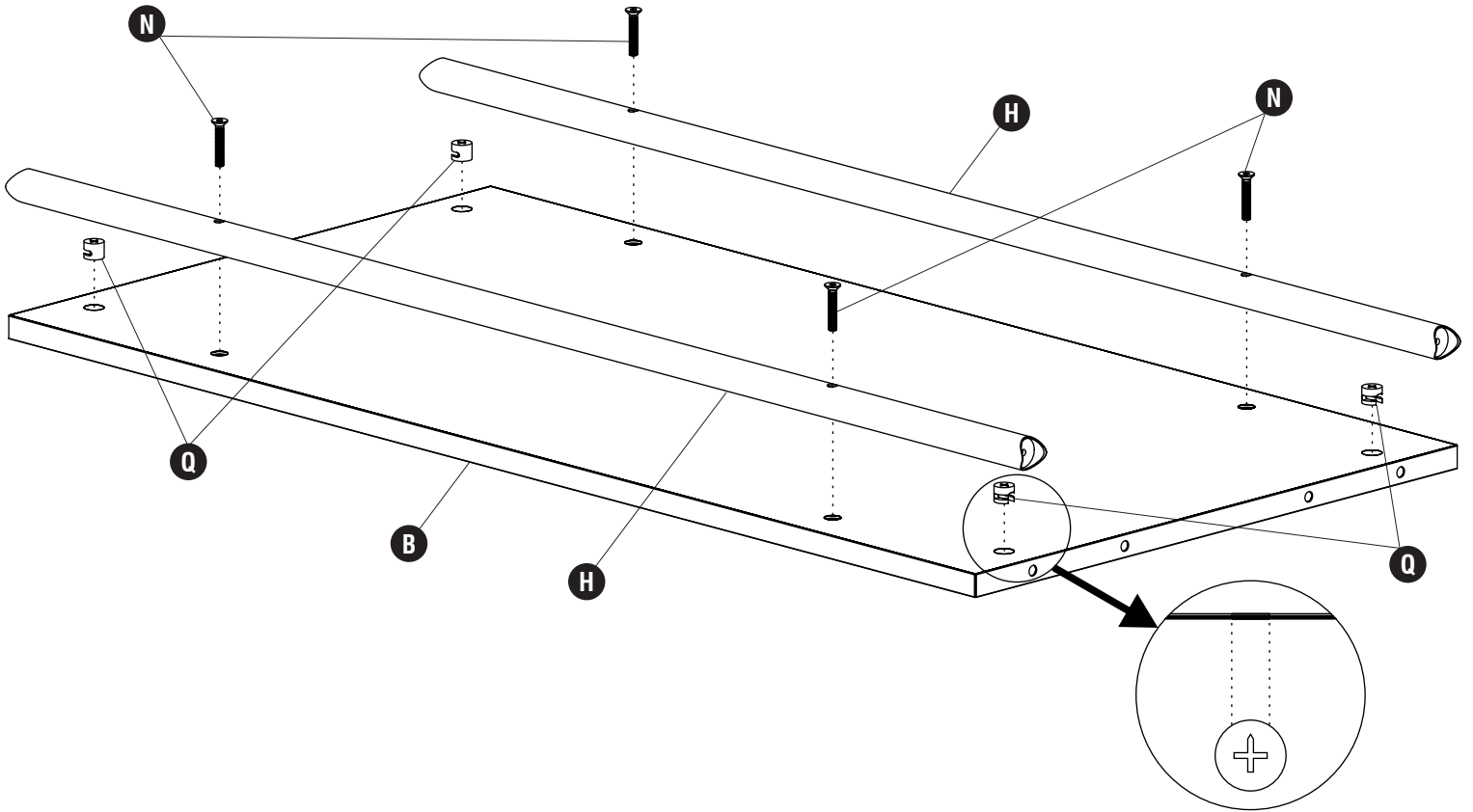

or

For Model 3906/3907
Pour le modèle 3906/3907
Para el modelo 3906/3907

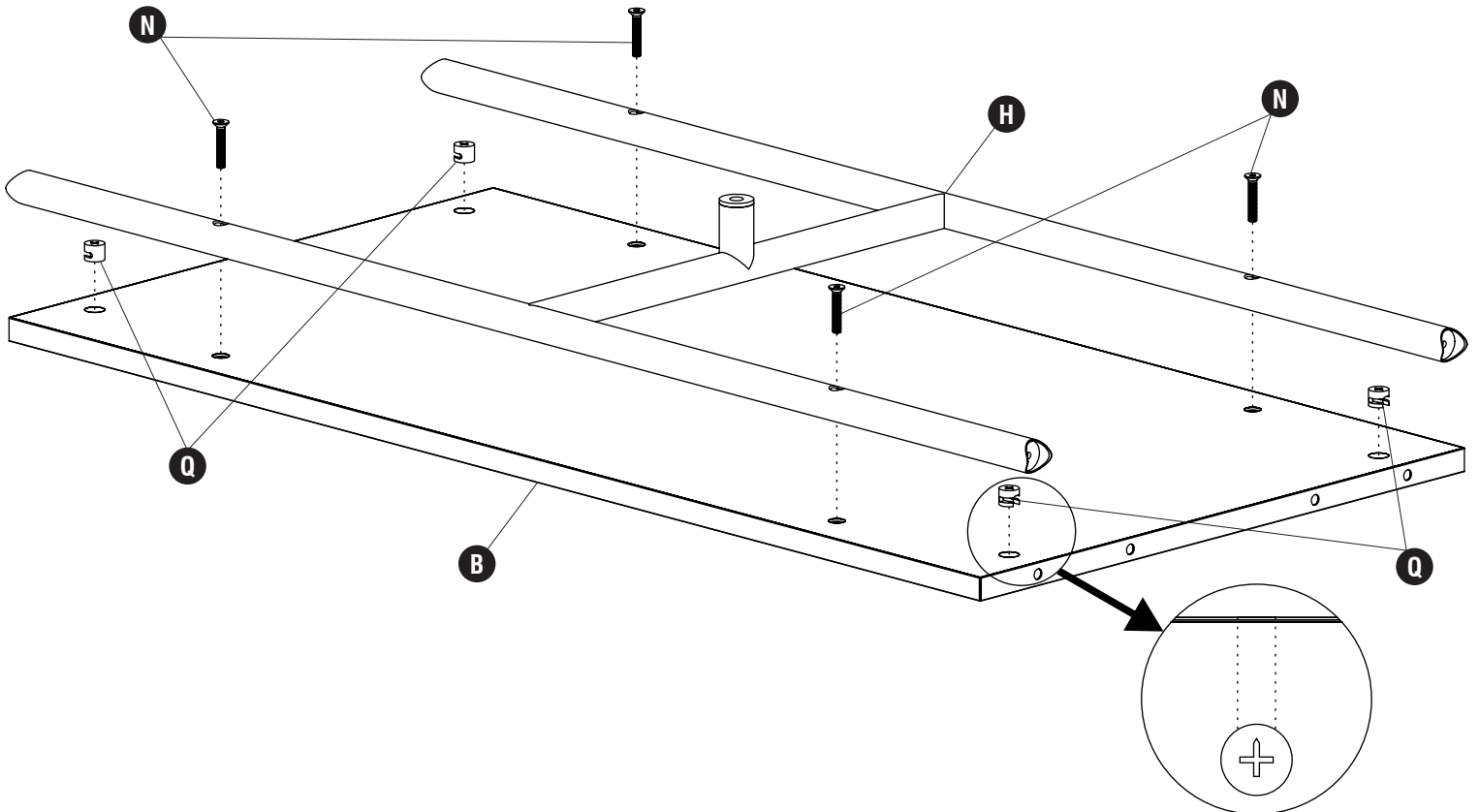

2 **O** (7) **P** (4)

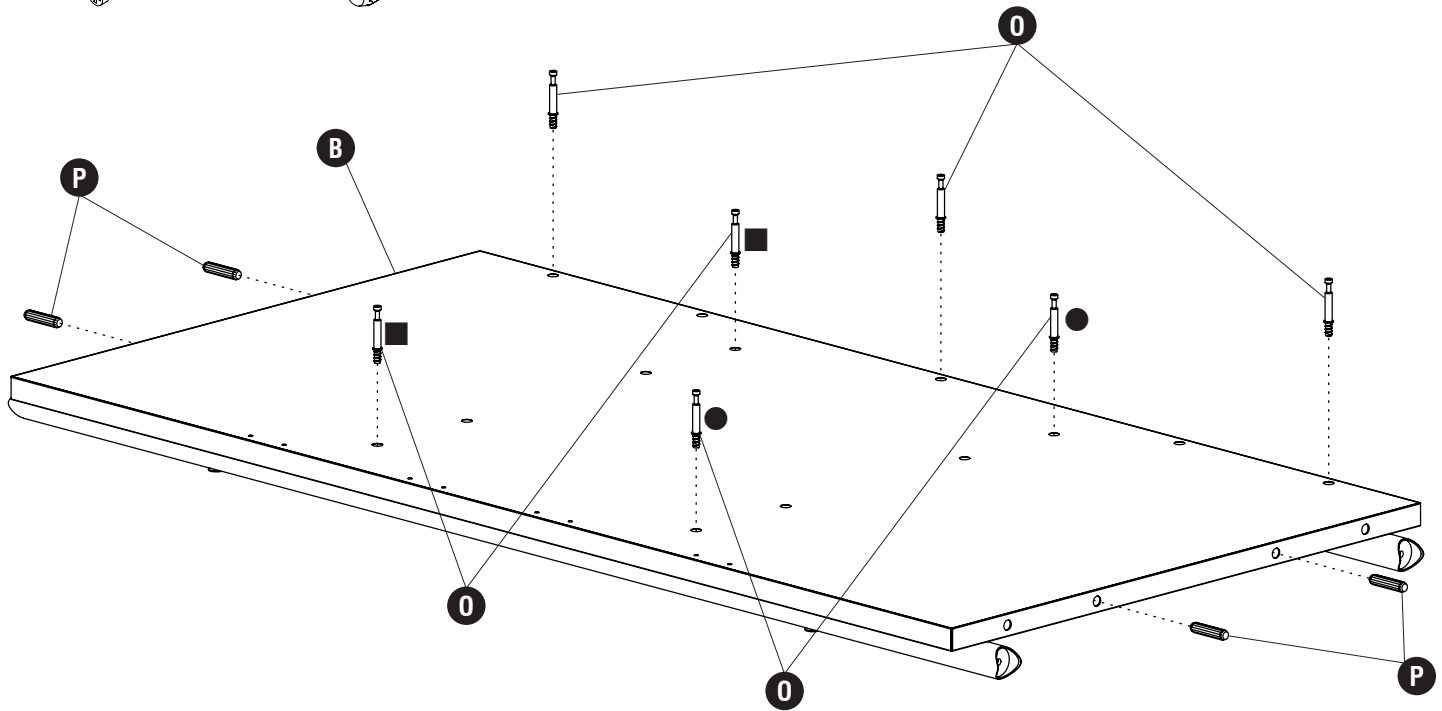

1 divider is required, 2 is optional. ■ for left divider, ● for right divider.
1 diviseur est requis, 2 est facultatif. ■ pour le diviseur gauche, ● pour le diviseur droit.
 Se requiere 1 divisor, 2 es opcional. ■ para el divisor izquierdo, ● para el divisor derecho.

3 **O** (7) **P** (4) **Q** (4)

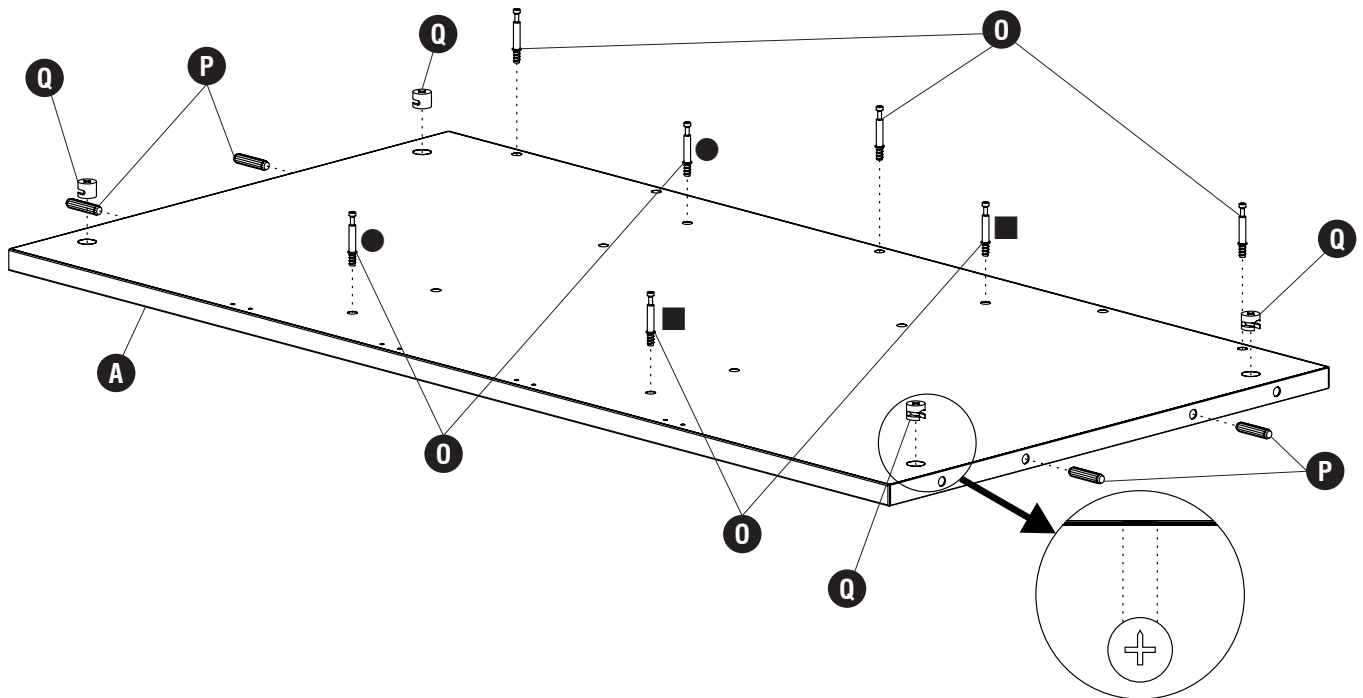

1 divider is required, 2 is optional. ■ for left divider, ● for right divider.
1 diviseur est requis, 2 est facultatif. ■ pour le diviseur gauche, ● pour le diviseur droit.
 Se requiere 1 divisor, 2 es opcional. ■ para el divisor izquierdo, ● para el divisor derecho.

4

For Model 3907 / 3908
Pour le modèle 3907 / 3908
Para el modelo 3907 / 3908



For Model 3906
Pour le modèle 3906
Para el modelo 3906



Note: Assembly requires one divider, having two is optional.
Noter: L'assemblage nécessite un diviseur, en avoir deux est facultatif.
Nota: El ensamblaje requiere un divisor, tener dos es opcional.

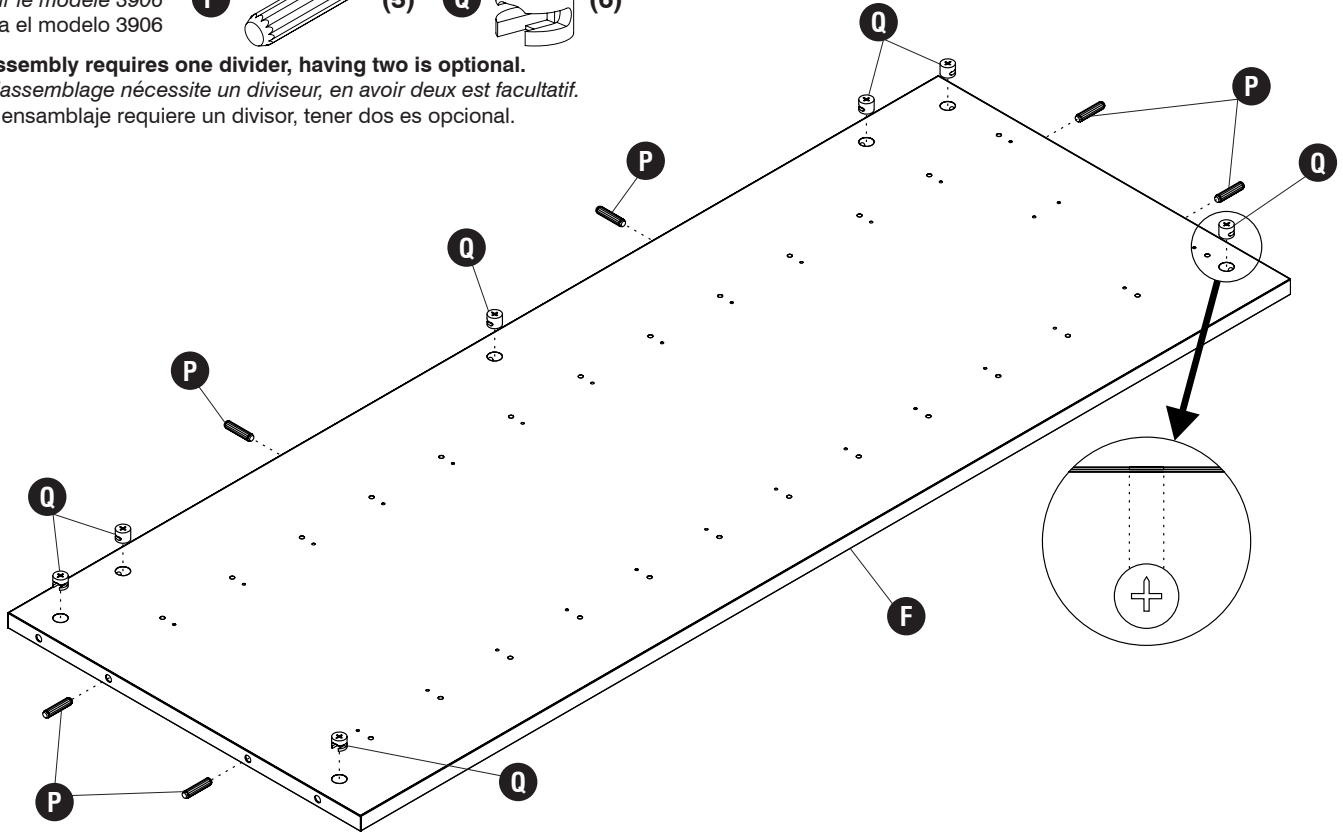

5

For Model 3907 / 3908
Pour le modèle 3907 / 3908
Para el modelo 3907 / 3908



For Model 3906
Pour le modèle 3906
Para el modelo 3906



Note: Bottom 2 screws only for Models 3907/3908
Noter: 2 vis inférieures uniquement pour les modèles 3907/3908
Nota: 2 tornillos inferiores solo para los modelos 3907/3908

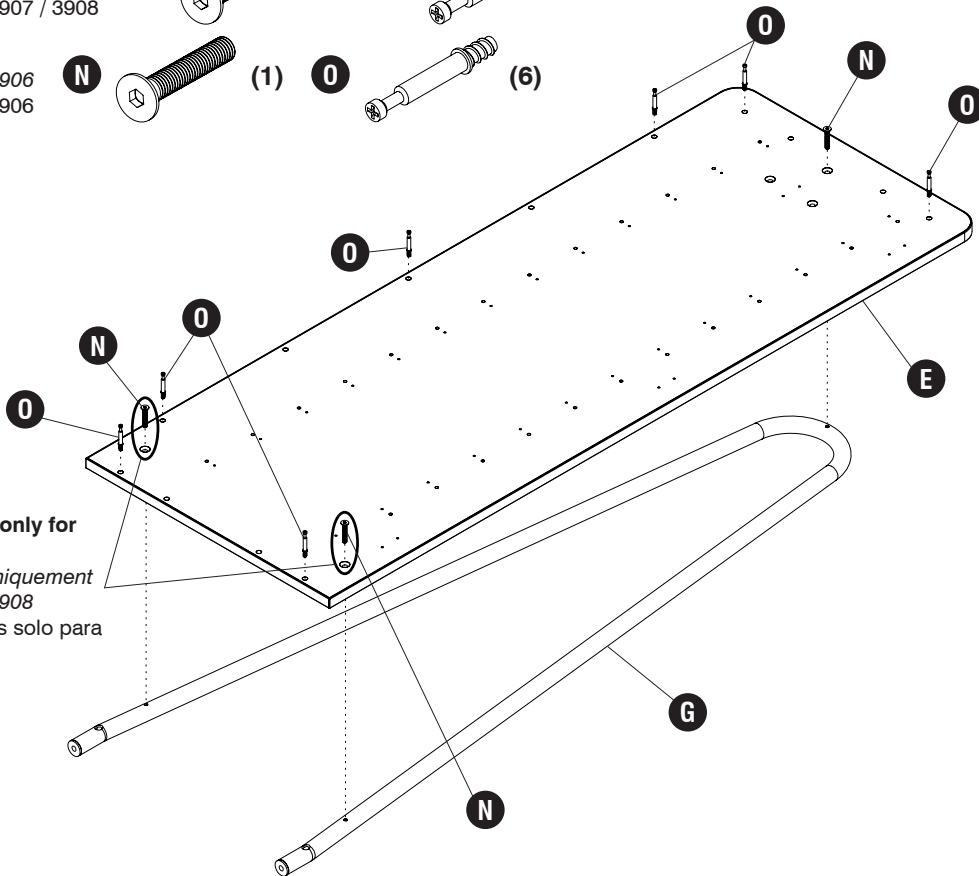

6 **N** (2)

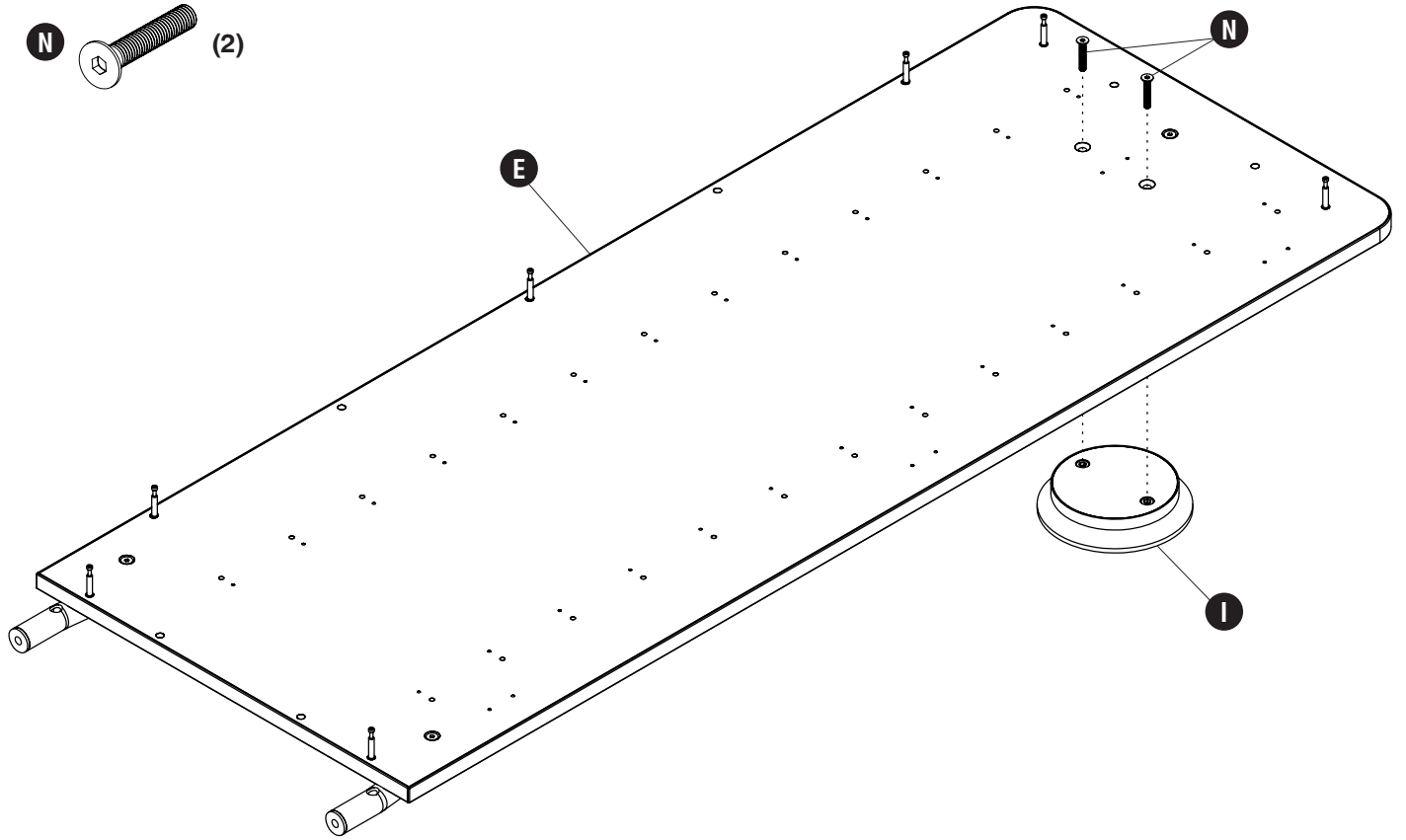

Repeat steps 5 & 6 for the left side panel.
Répétez les étapes 5 et 6 pour le panneau latéral gauche.
 Repita los pasos 5 y 6 para el panel lateral izquierdo.

7 **For Model 3907 / 3908**
Pour le modèle 3907 / 3908
 Para el modelo 3907 / 3908

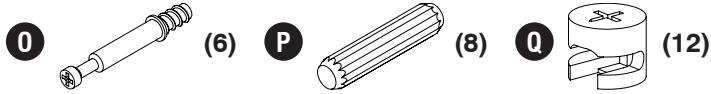

For Model 3906
Pour le modèle 3906
 Para el modelo 3906

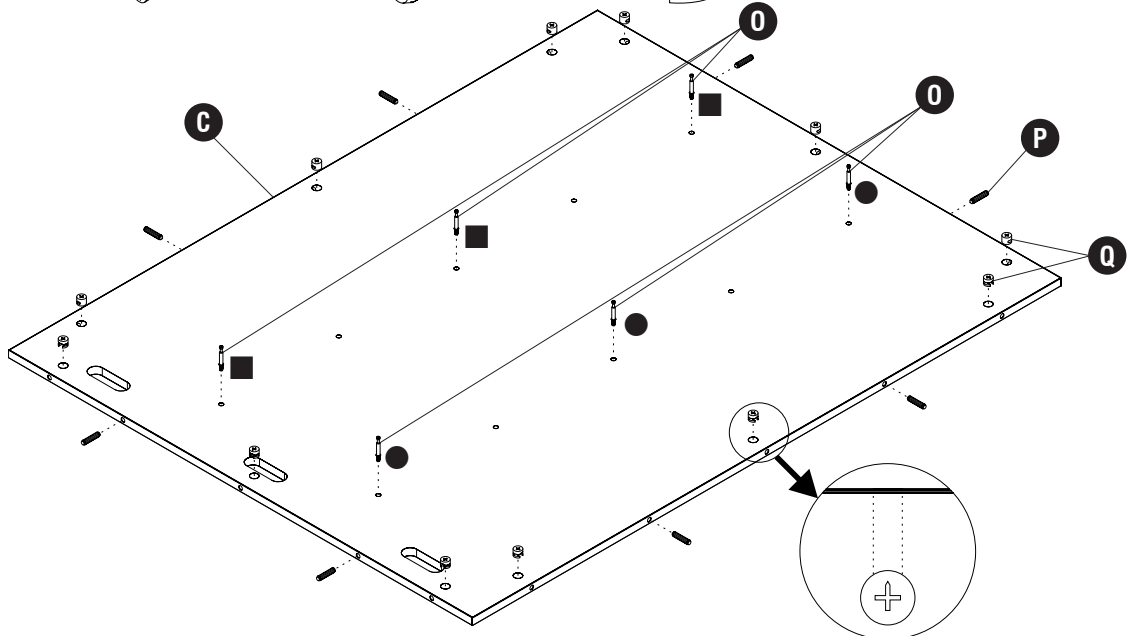
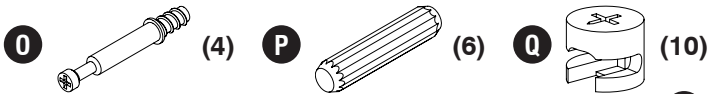

1 divider is required, 2 is optional. ■ for left divider, ● for right divider.
1 diviseur est requis, 2 est facultatif. ■ pour le diviseur gauche, ● pour le diviseur droit.
 Se requiere 1 divisor, 2 es opcional. ■ para el divisor izquierdo, ● para el divisor derecho.

8

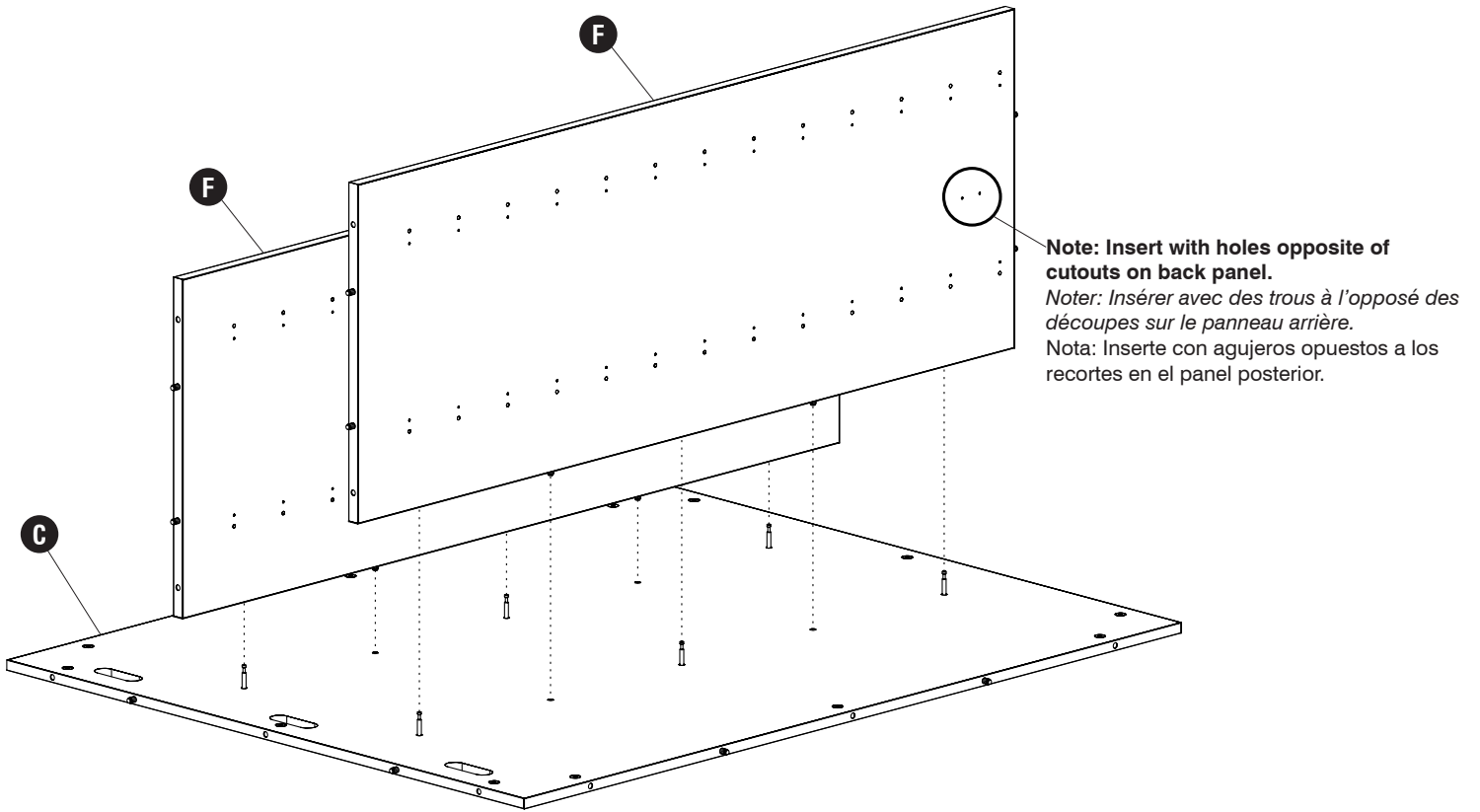

9

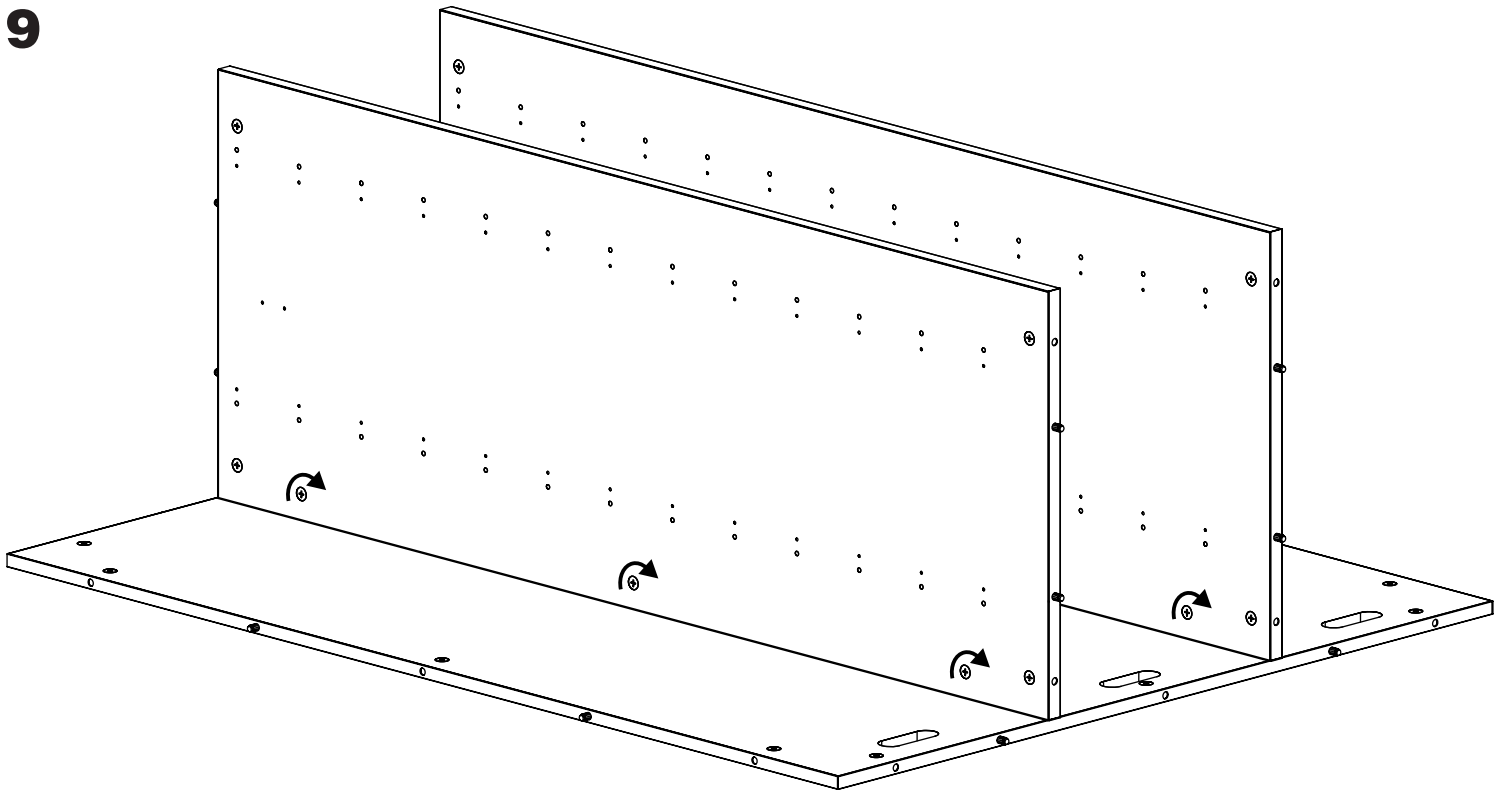

Tighten cams on the dividers to secure them to the back panel.
Serrez les cames sur les séparateurs pour les fixer au panneau arrière.
Apriete las levas en los divisores para asegurarlos al panel posterior.

10

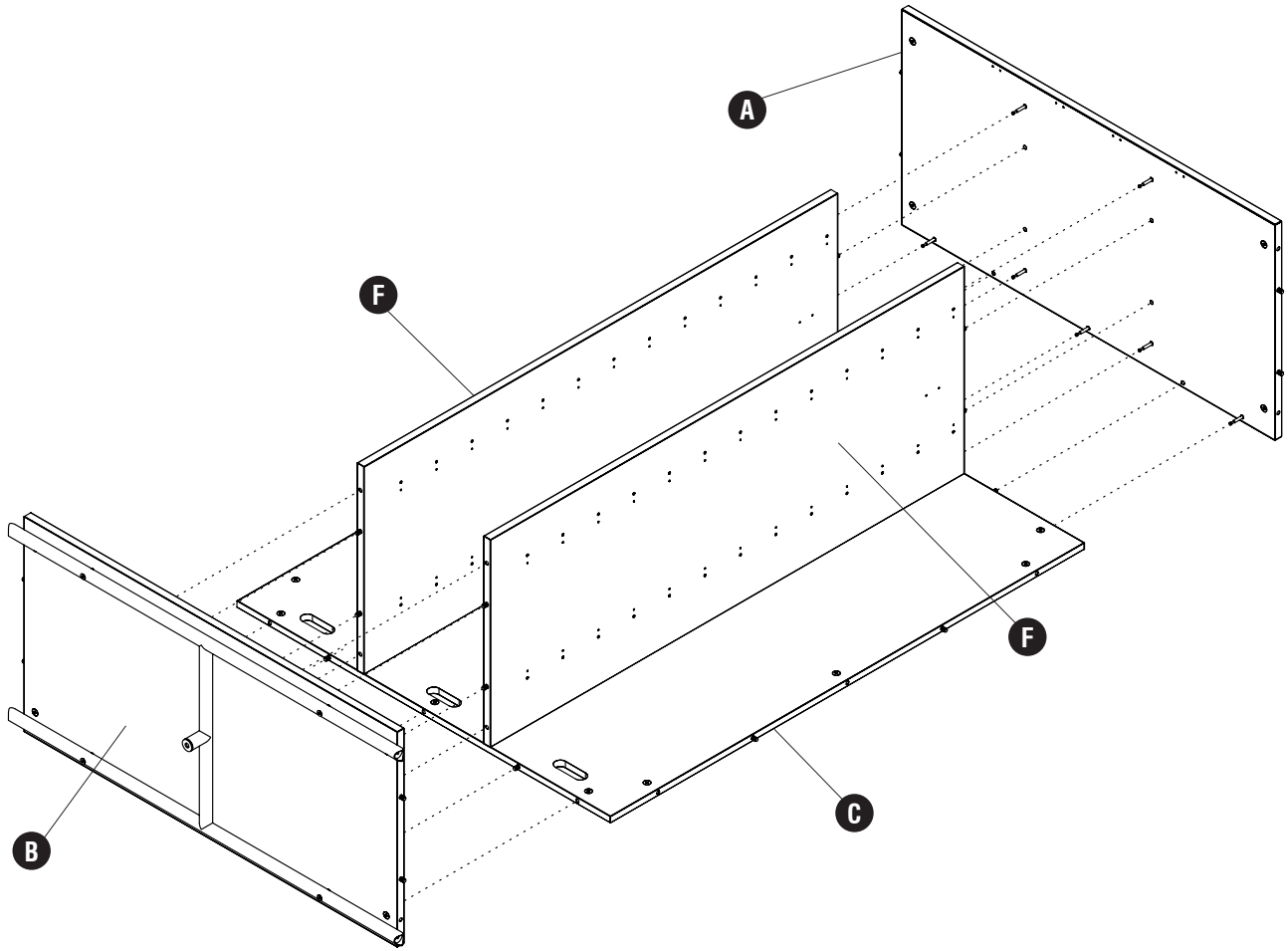

11

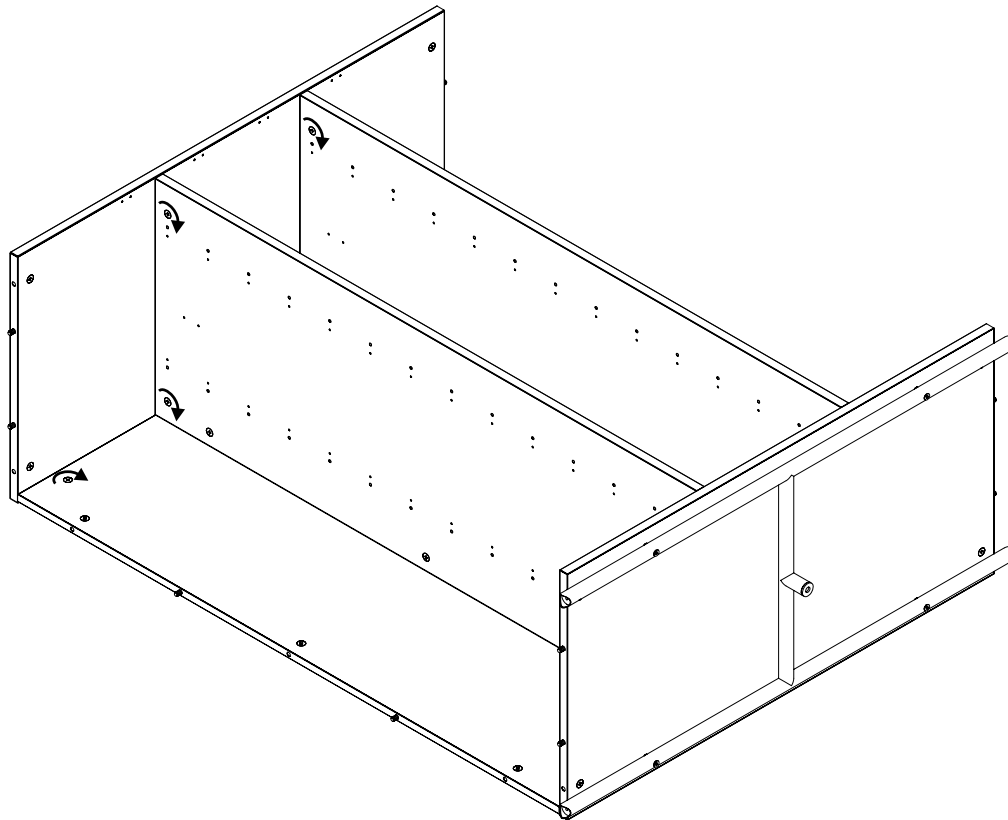

Tighten cams on dividers and back panel to secure top and bottom panels.

Serrez les cames sur les séparateurs et le panneau arrière pour fixer les panneaux supérieur et inférieur.

Apriete las levas en los divisores y el panel posterior para asegurar los paneles superior e inferior.

12 N (4)

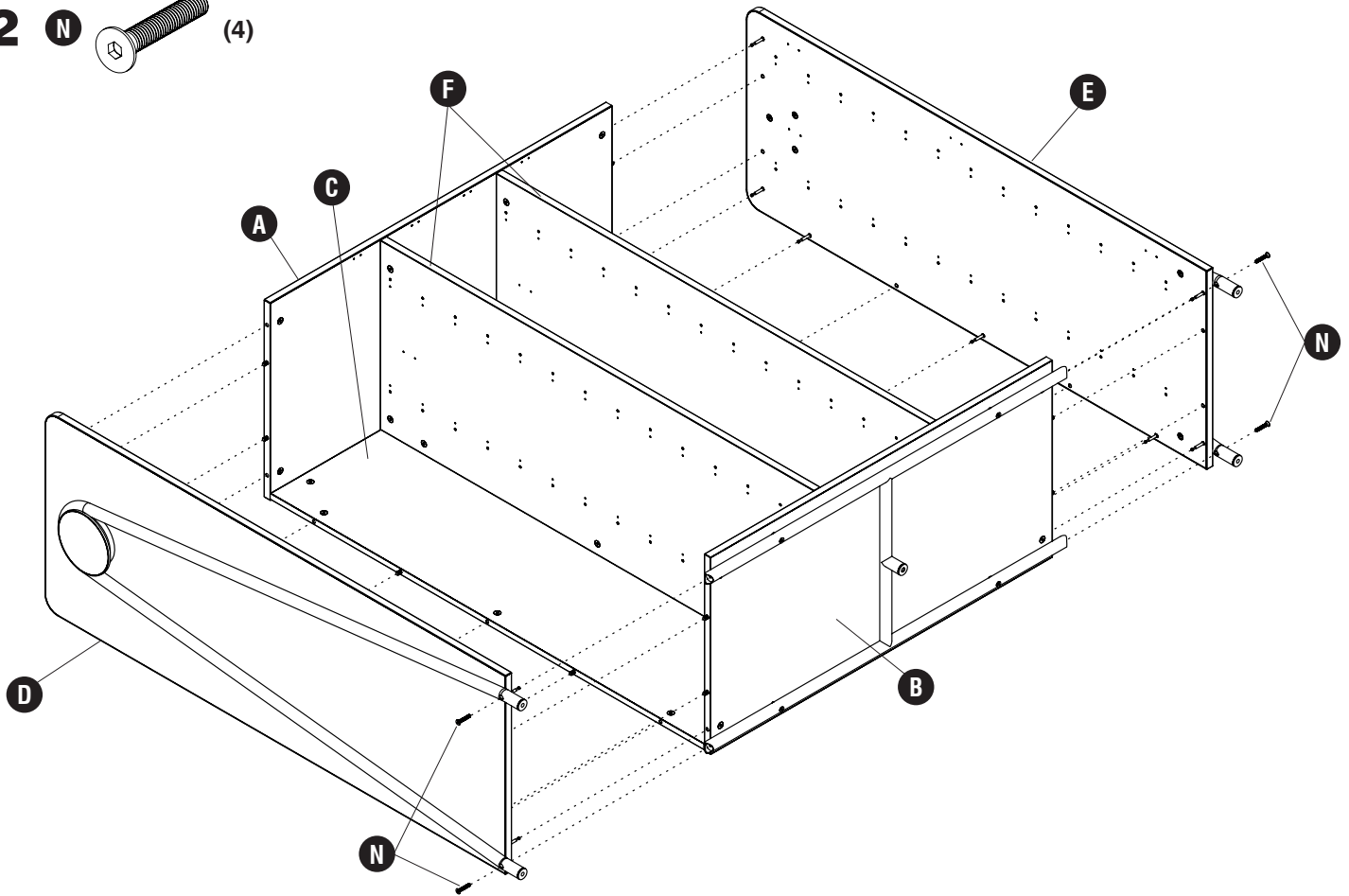
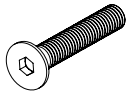

13

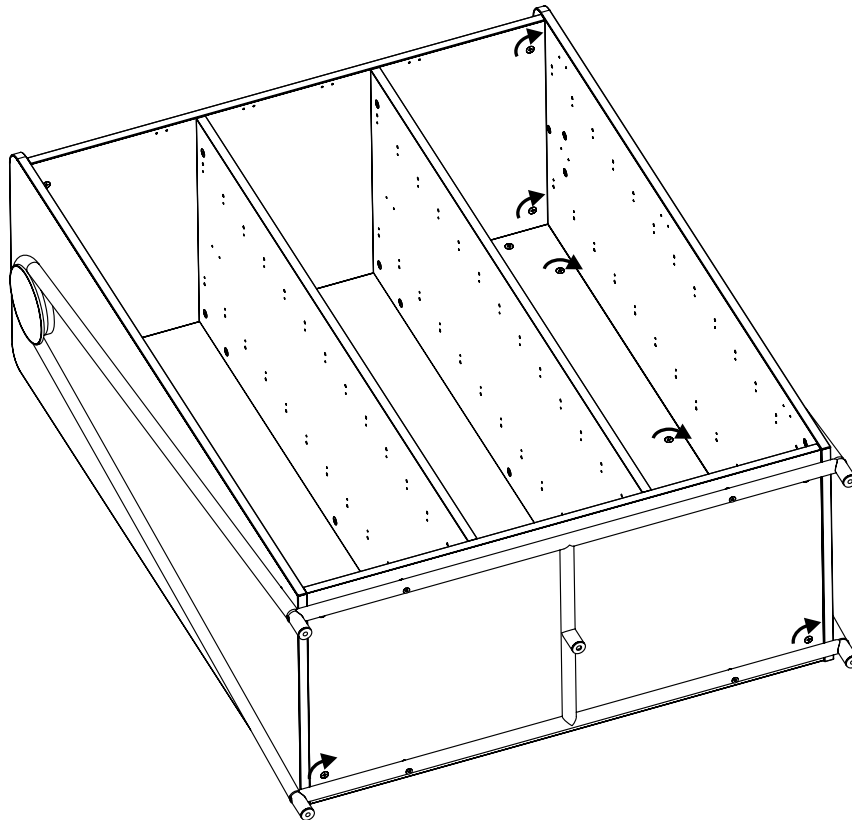

Tighten cams on top, bottom, and back panel to secure side panels.

Serrez les cames en haut, en bas et sur le panneau arrière pour fixer les panneaux latéraux.

Apriete las levas en el panel superior, inferior y posterior para asegurar los paneles laterales.

14 **L**  (2) **M**  (3) **R**  (1)

For Model 3906/3907
Pour le modèle 3906/3907
Para el modelo 3906/3907

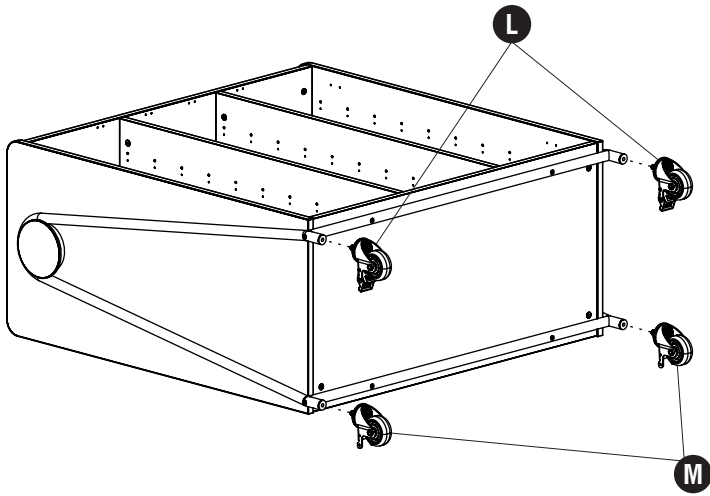

For Model 3908
Pour le modèle 3908
Para el modelo 3908

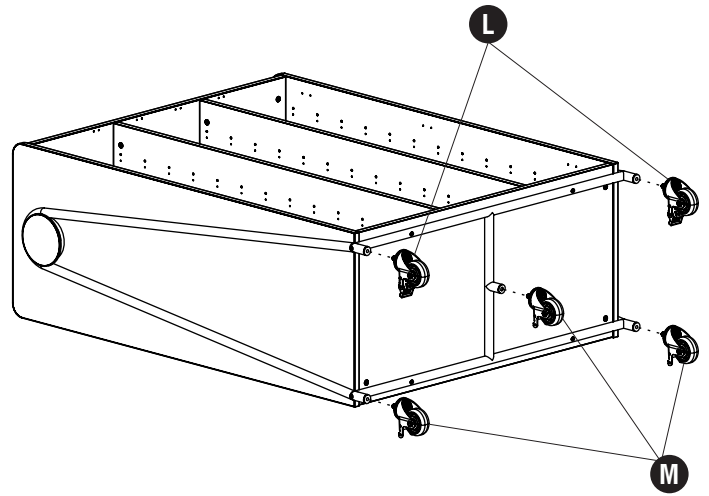

or

Using the 19mm open ended wrench, tighten the nut on all the casters to secure them.
À l'aide de la clé ouverte de 19 mm, serrez l'écrou sur toutes les roulettes pour les fixer.
Usando la llave de boca abierta de 19 mm, apriete la tuerca en todas las ruedas para asegurarlas.

15

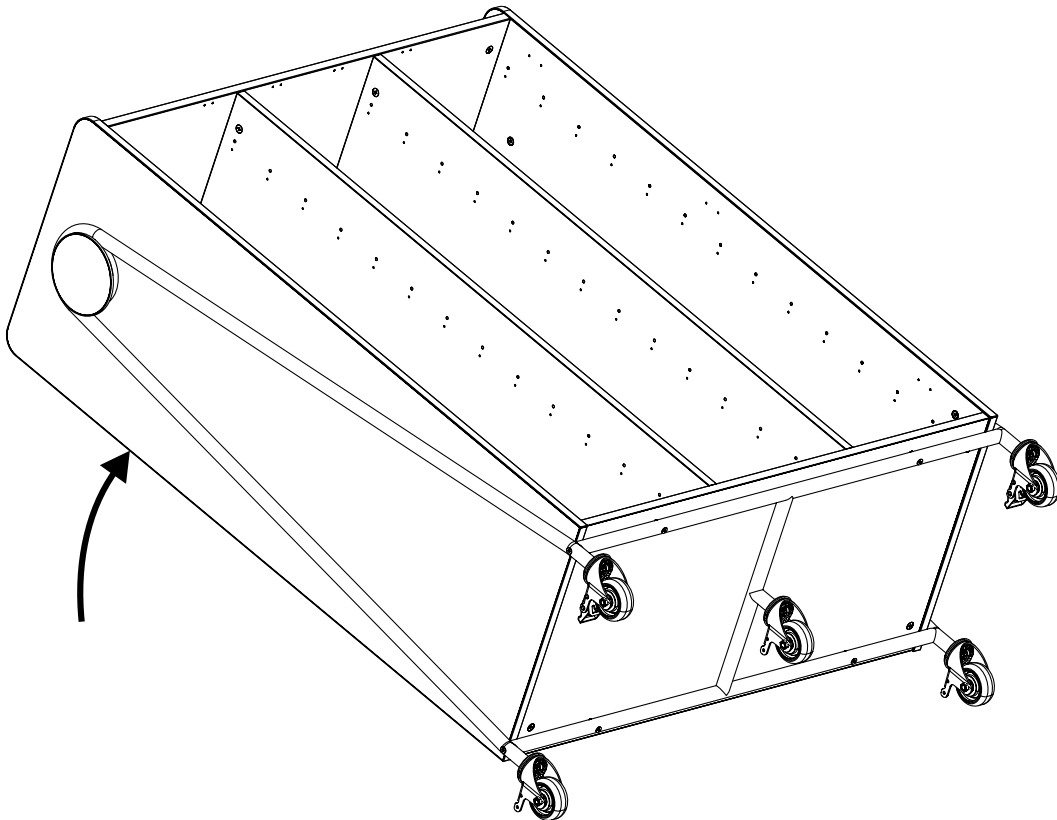

Lift assembly from the top, and rotate to have the assembly placed on casters.
Soulevez l'assemblage par le haut et faites-le pivoter pour le placer sur des roulettes.
Levante el ensamblaje desde la parte superior y gírelo para colocar el ensamblaje sobre ruedas.

16 CC

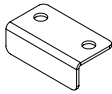

(1)

DD

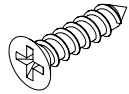

(2)

Note: Holes for triple doors.

Noter: Trous pour portes triples.

Nota: Agujeros para puertas triples.

Note: Holes for double doors.

Noter: Trous pour portes doubles.

Nota: Agujeros para puertas dobles.

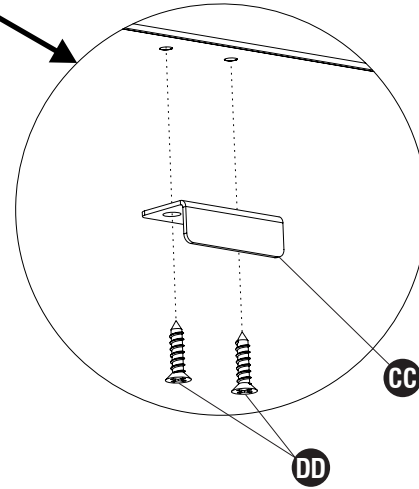
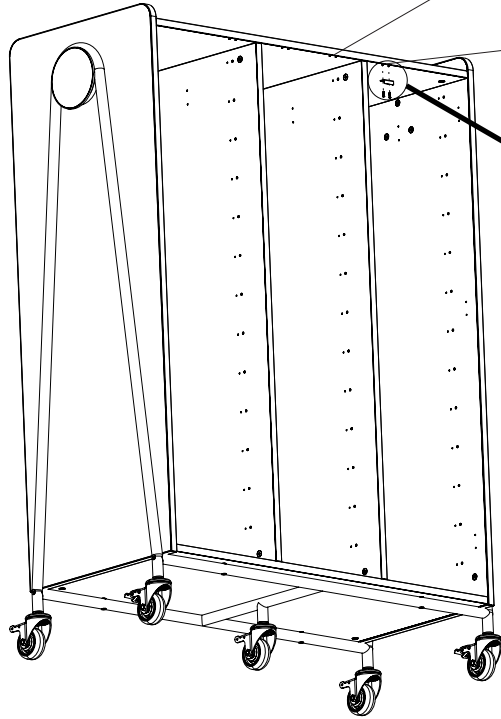

Step is optional, and only for installing 1 door. Repeat for 2 doors.

L'étape est facultative et uniquement pour l'installation d'une porte. Répétez l'opération pour 2 portes.

El paso es opcional, y solo para instalar 1 puerta. Repita para 2 puertas.

17 AA

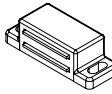

(1)

DD

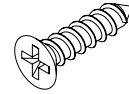

(2)

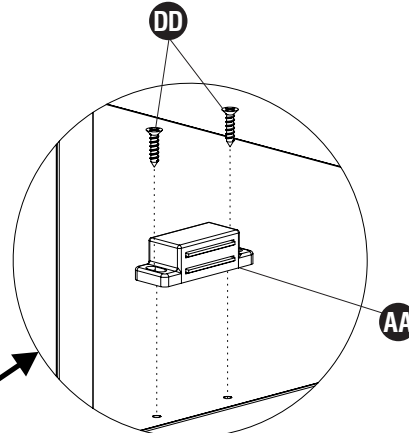
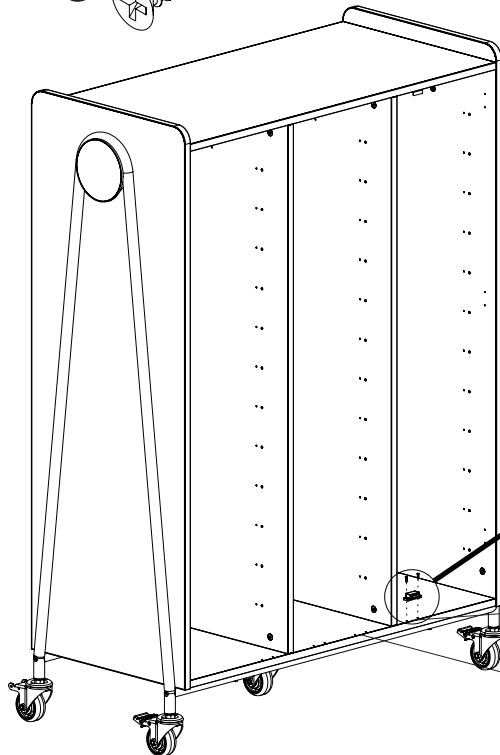

Note: Holes for double doors.

Noter: Trous pour portes doubles.

Nota: Agujeros para puertas dobles.

Note: Holes for triple doors.

Noter: Trous pour portes triples.

Nota: Agujeros para puertas triples.

Step is optional, and only for installing 1 door. Repeat for 2 doors.

L'étape est facultative et uniquement pour l'installation d'une porte. Répétez l'opération pour 2 portes.

El paso es opcional, y solo para instalar 1 puerta. Repita para 2 puertas.

18

For Model 3908
 Pour le modèle 3908
 Para el modelo 3908



For Model 3906 / 3907
 Pour le modèle 3906 / 3907
 Para el modelo 3906 / 3907

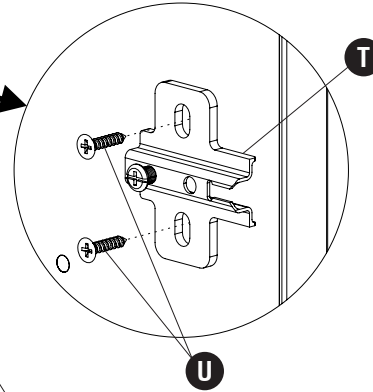
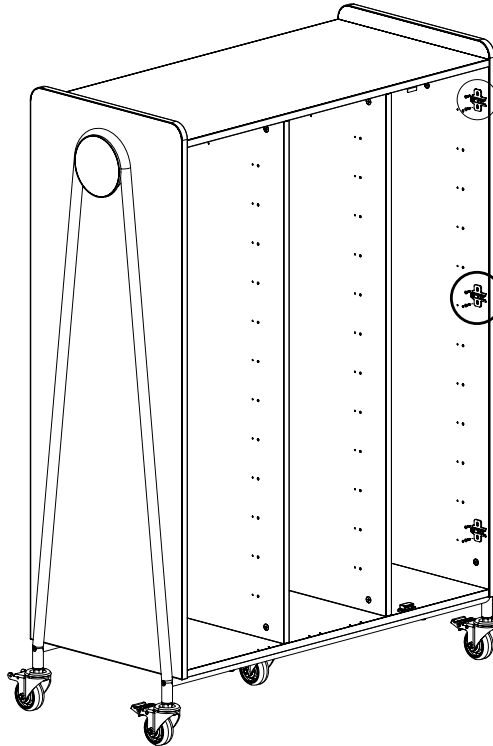

Note: Middle door wing and screws are only for Model 3908.

Noter: L'aile de porte centrale et les vis sont uniquement pour le modèle 3908.
Nota: El ala central y los tornillos de la puerta son solo para el modelo 3908.

Step is optional, and only for installing 1 door. Repeat for 2 doors.

L'étape est facultative et uniquement pour l'installation d'une porte. Répétez l'opération pour 2 portes.

El paso es opcional, y solo para instalar 1 puerta. Repita para 2 puertas.

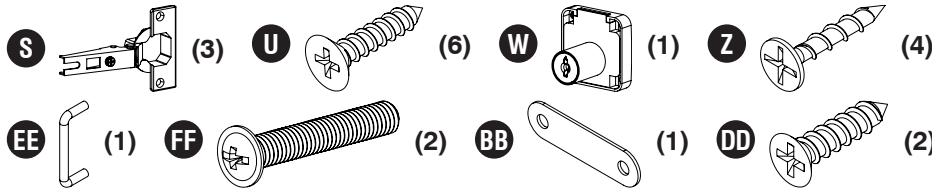
19

Note: Do not tighten all the way.
Noter: Ne serrez pas complètement.
Nota: No lo apriete por completo.

Note: Middle door wing and screws are only for Model 3908.

Noter: L'aile de porte centrale et les vis sont uniquement pour le modèle 3908.
Nota: El ala central y los tornillos de la puerta son solo para el modelo 3908.

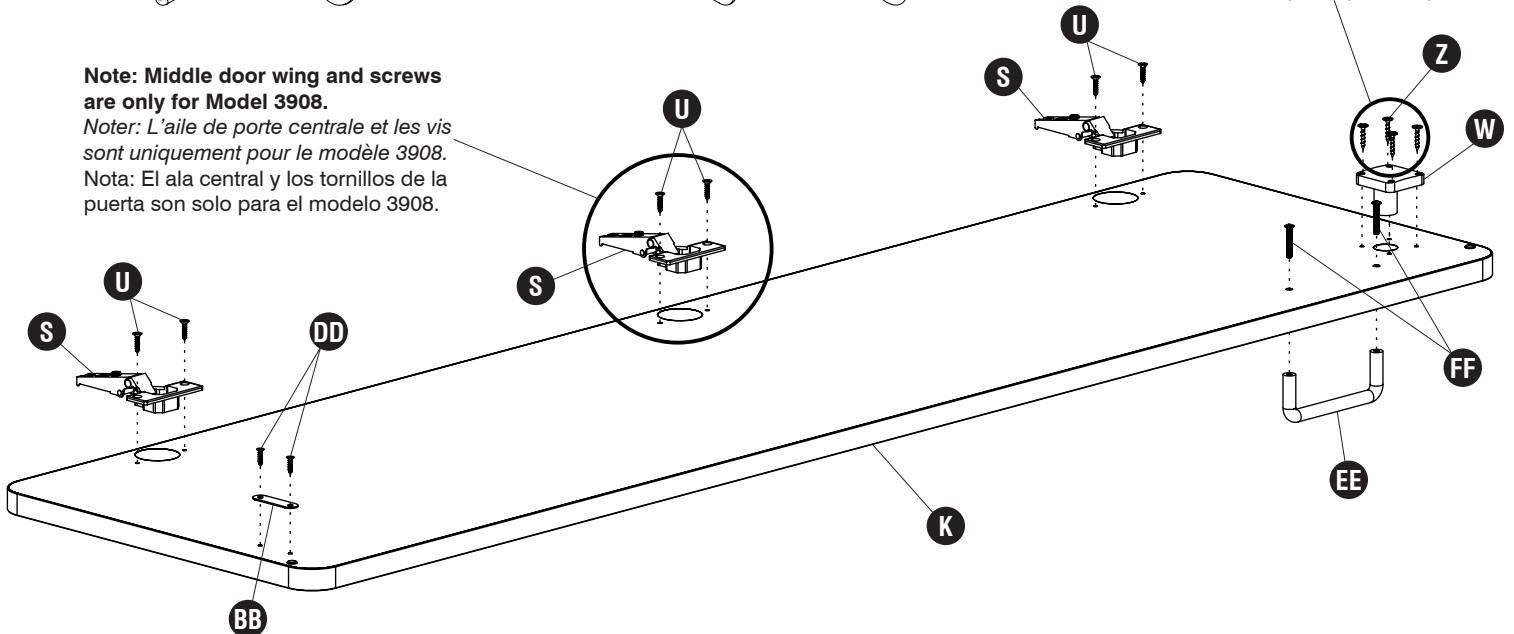

Step is optional, and only for installing 1 door. Repeat for 2 doors.

L'étape est facultative et uniquement pour l'installation d'une porte. Répétez l'opération pour 2 portes.

El paso es opcional, y solo para instalar 1 puerta. Repita para 2 puertas.

20 X (1)



Note: Tighten screws for the lock after installing the door lock trim.

Noter: Serrez les vis de la serrure après avoir installé la garniture de serrure de porte.

Nota: Apriete los tornillos de la cerradura después de instalar la moldura de la cerradura de la puerta.

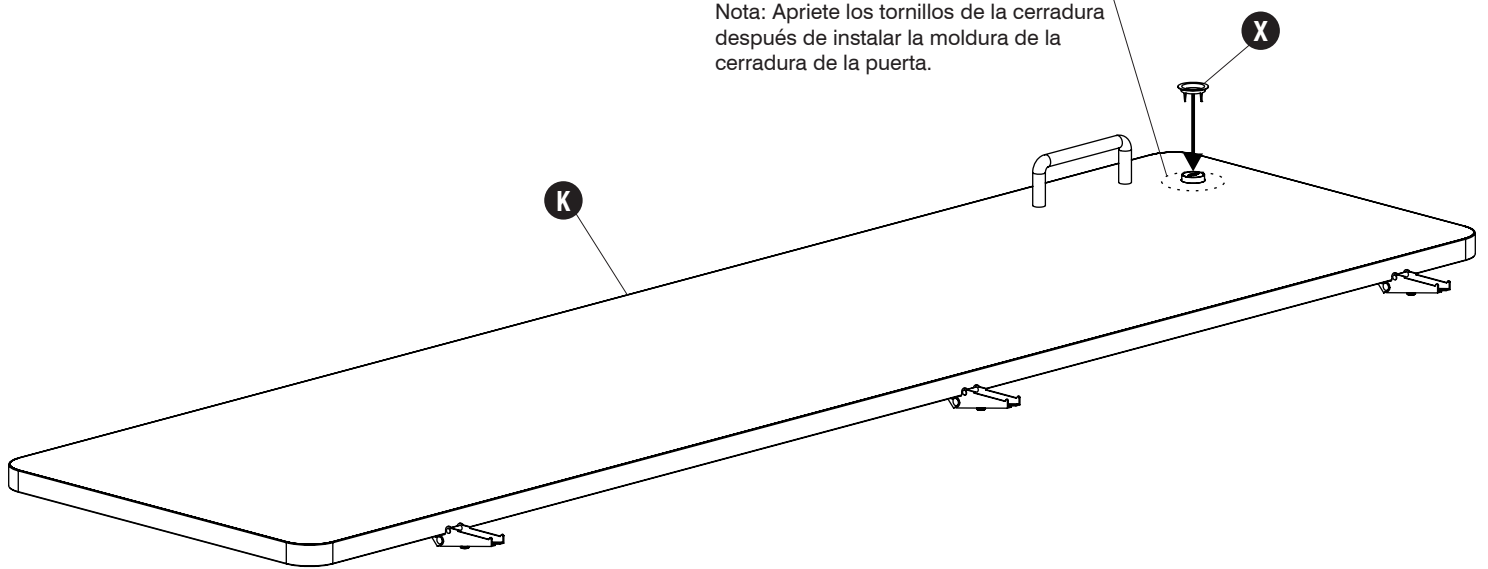

Step is optional, and only for installing 1 door. Repeat for 2 doors.

L'étape est facultative et uniquement pour l'installation d'une porte. Répétez l'opération pour 2 portes.

El paso es opcional, y solo para instalar 1 puerta. Repita para 2 puertas.

21

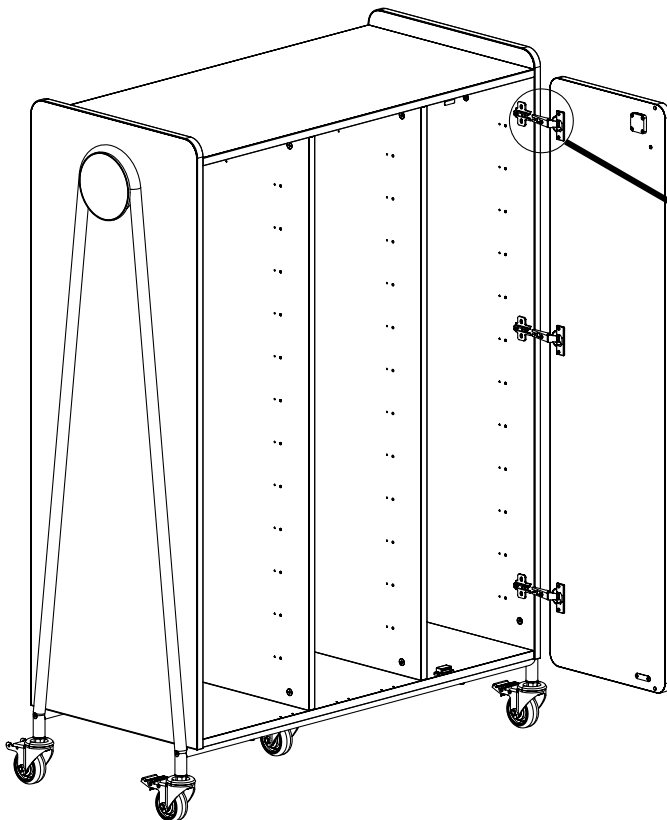

Note: Slide the door wings onto the frame wings, and tighten the adjustment screws.

Noter: Faites glisser les battants de porte sur les battants du cadre et serrez les vis de réglage.

Nota: Deslice las aletas de la puerta sobre las aletas del marco y apriete los tornillos de ajuste.

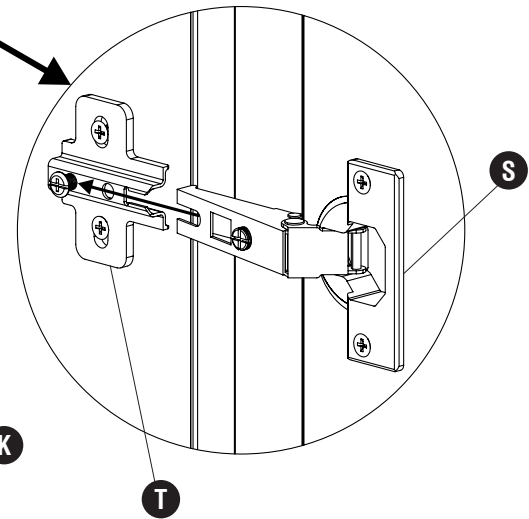

Step is optional, and only for installing 1 door. Repeat for 2 doors.

L'étape est facultative et uniquement pour l'installation d'une porte. Répétez l'opération pour 2 portes.

El paso es opcional, y solo para instalar 1 puerta. Repita para 2 puertas.

22

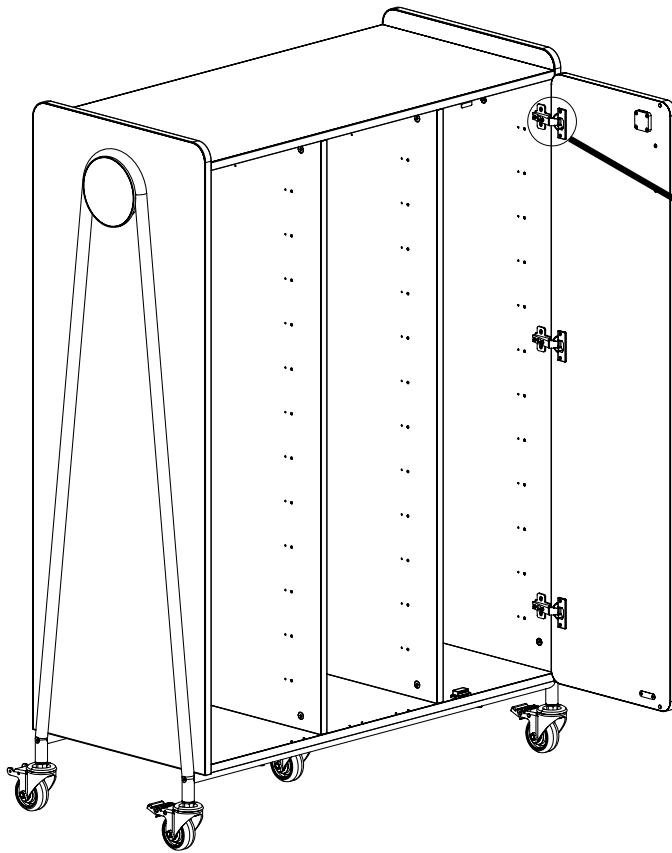

Note: Using minor adjustments, adjust door hinges.

Noter: En utilisant des ajustements mineurs, ajustez les charnières de porte.
Nota: Usando ajustes menores, ajuste las bisagras de la puerta.

Step is optional, and only for installing 1 door. Repeat for 2 doors.

L'étape est facultative et uniquement pour l'installation d'une porte. Répétez l'opération pour 2 portes.

El paso es opcional, y solo para instalar 1 puerta. Repita para 2 puertas.

23

HH



(4)

DD

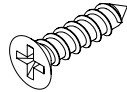

(8)

Note: Glides with an 'R' sticker go on the right side of a column.

Noter: Les patins avec un autocollant 'R' se trouvent sur le côté droit d'une colonne.

Nota: Las diapositivas con una etiqueta 'R' van en el lado derecho de una columna.

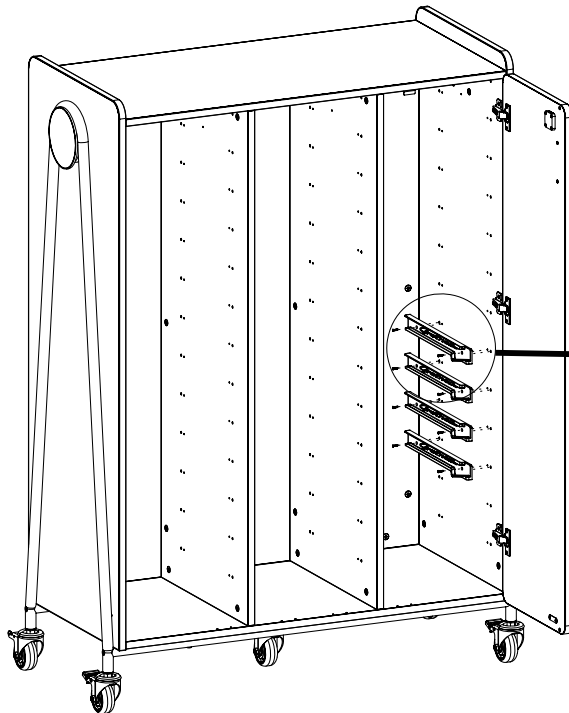

DD

HH

DD

If totes are ordered, insert glides with angled end towards the front of the assembly.

Si les bacs sont commandés, insérez des patins à extrémité inclinée vers l'avant de l'assemblage.

Si se solicitan bolsas, inserte deslizadores con el extremo en ángulo hacia la parte frontal del conjunto.

24 II



(4)

DD

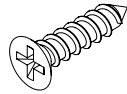

(8)

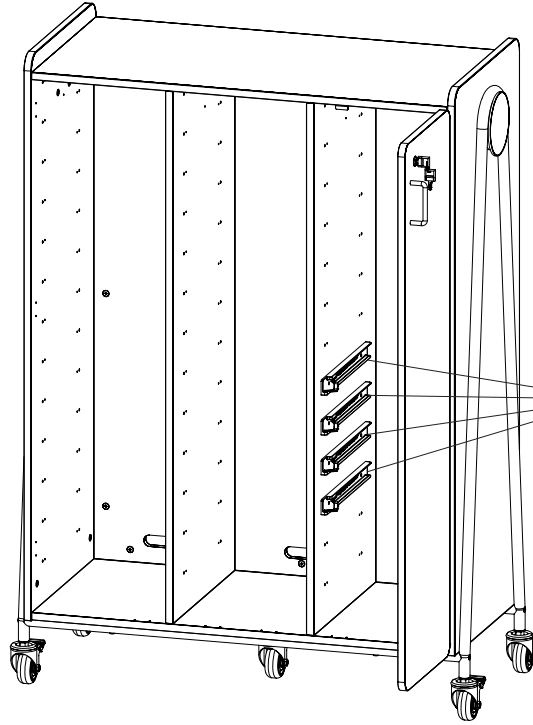

Note: Glides with an 'L' sticker go on the left side of a column.

Noter: Les patins avec un autocollant 'L' se trouvent sur le côté gauche d'une colonne.

Nota: Las diapositivas con una etiqueta 'L' van en el lado izquierdo de una columna.

Insert other glides in the same position as the divider/side panel.

Insérez les glissières de bacs avec une extrémité coudée sur le bord avant du diviseur/panneau latéral.

Inserte los portaobjetos con extremo en ángulo en el borde frontal del divisor/panel lateral.

25 GG

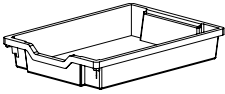

(3)

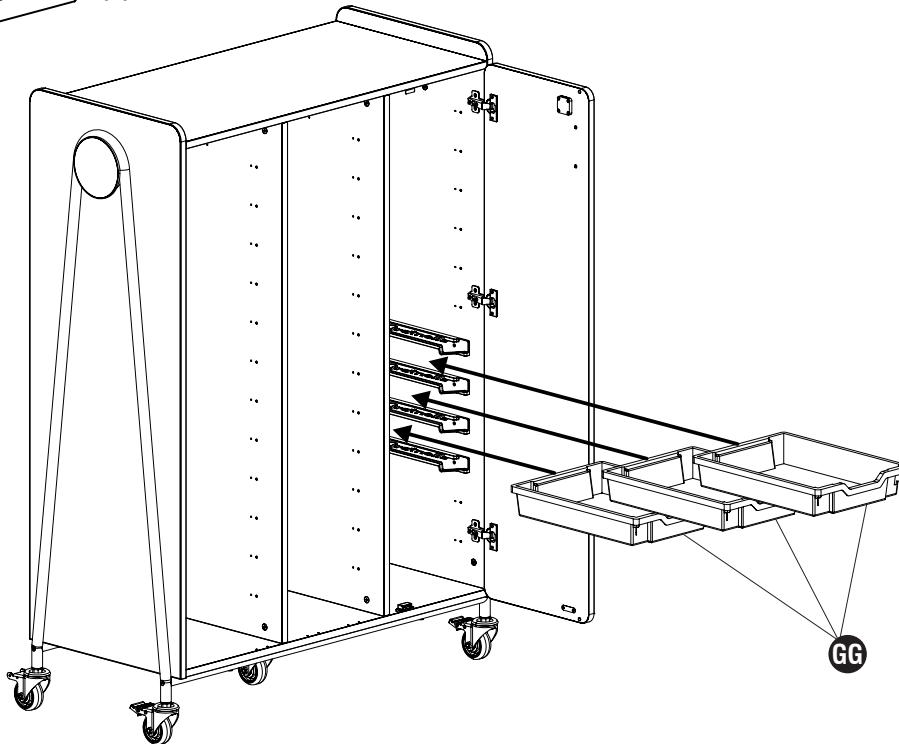

Totes without tote stop clips can slide freely in and out of the tote glides.

Les bacs sans clips de fermeture peuvent glisser librement dans les glissières du bac.

Los bolsos sin clips de tope pueden deslizarse libremente dentro y fuera de los portaobjetos.

26 KK (1) RR (1) SS (1) SS (1)

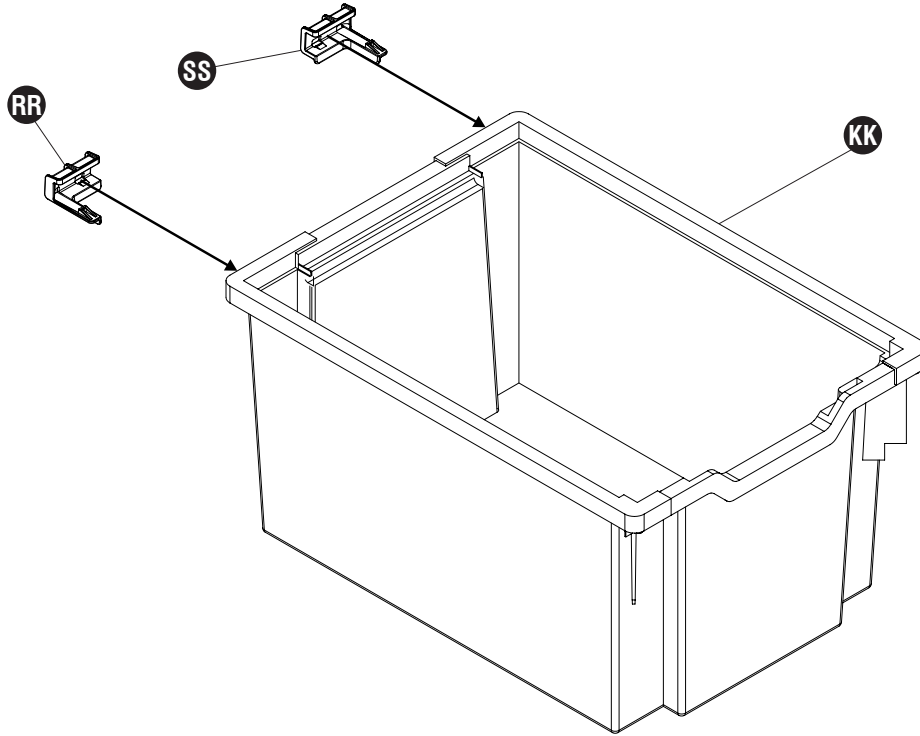

Tote stop clips are optional, if ordered they snap on the back of totes.

Les clips d'arrêt de fourre-tout sont facultatifs, s'ils sont commandés, ils se clipsent au dos des fourre-tout.
Los clips de detención de bolsas son opcionales, si se ordenan, se ajustan en la parte posterior de las bolsas.

27 KK (1)

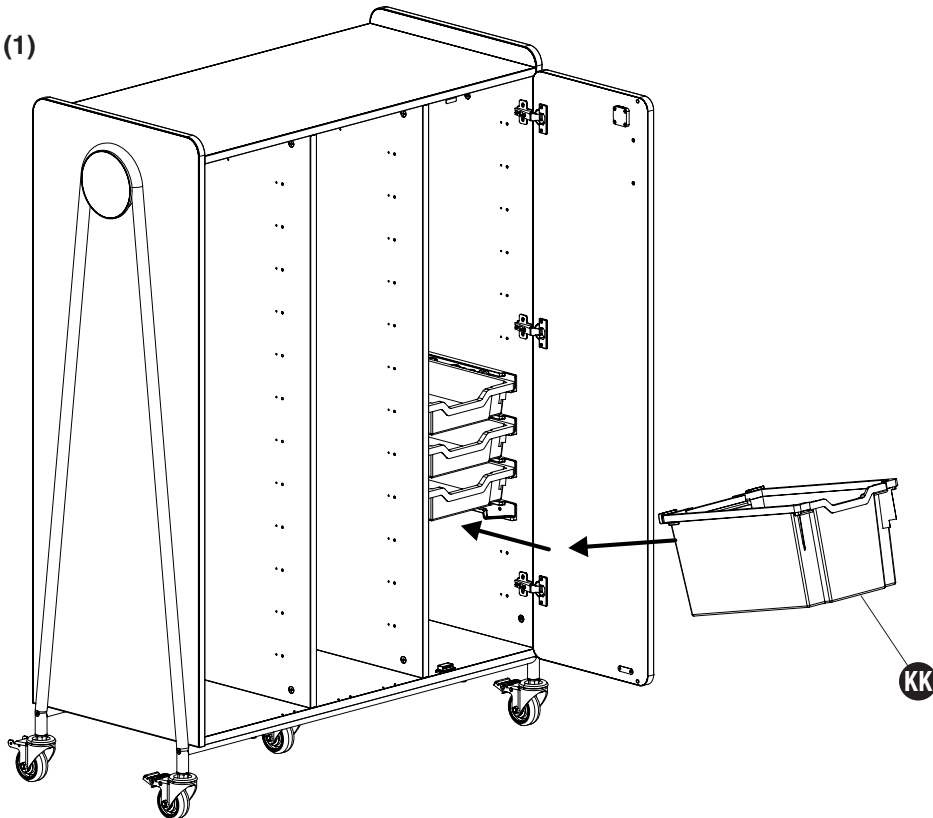

Totes with tote stop clips installed are inserted at an angle, then pushed in.

Les bacs avec des clips de butée installés sont insérés à un angle, puis enfoncés.

Las bolsas con clips de detención instalados se insertan en ángulo y luego se empujan hacia adentro.

28

MM



(2)

DD

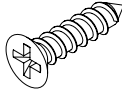

(4)

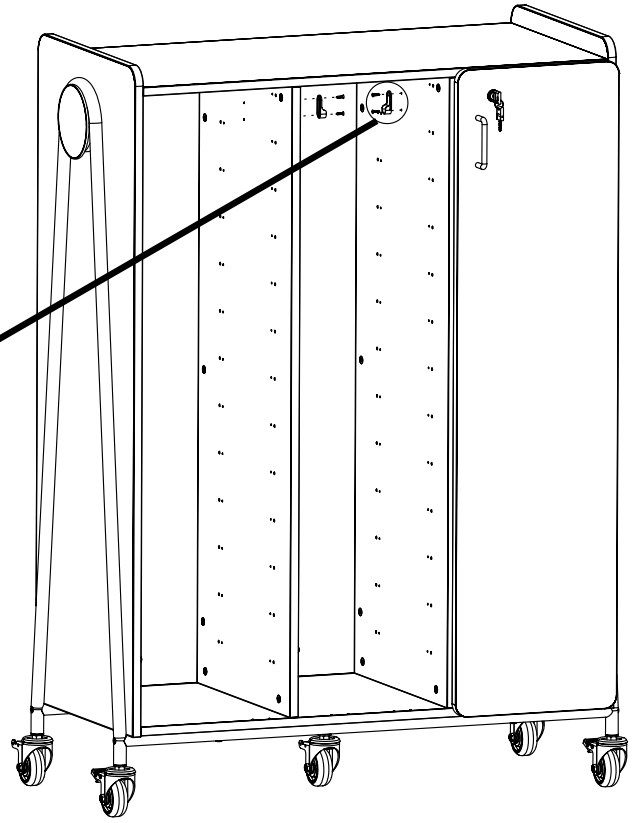
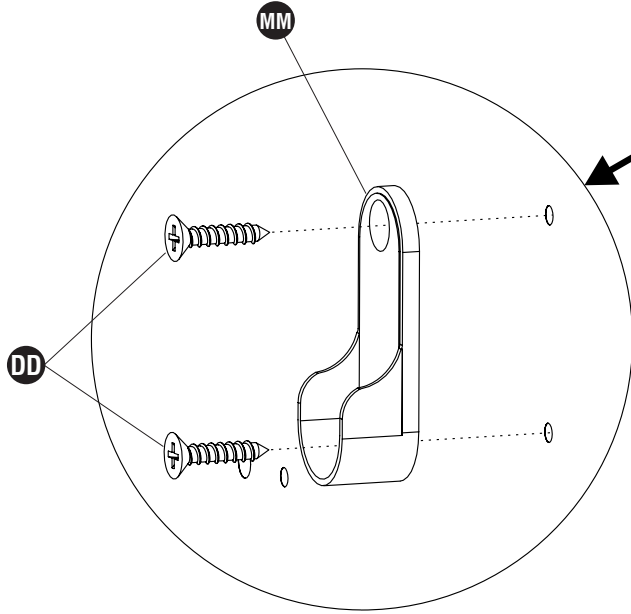

Step only for Models 3907/3908 if wardrobe bar is ordered.

Pas seulement pour les modèles 3907/3908 si la barre d'armoire est commandée.

Paso solo para los modelos 3907/3908 si se solicita la barra de guardarropa.

29

NN



(1)

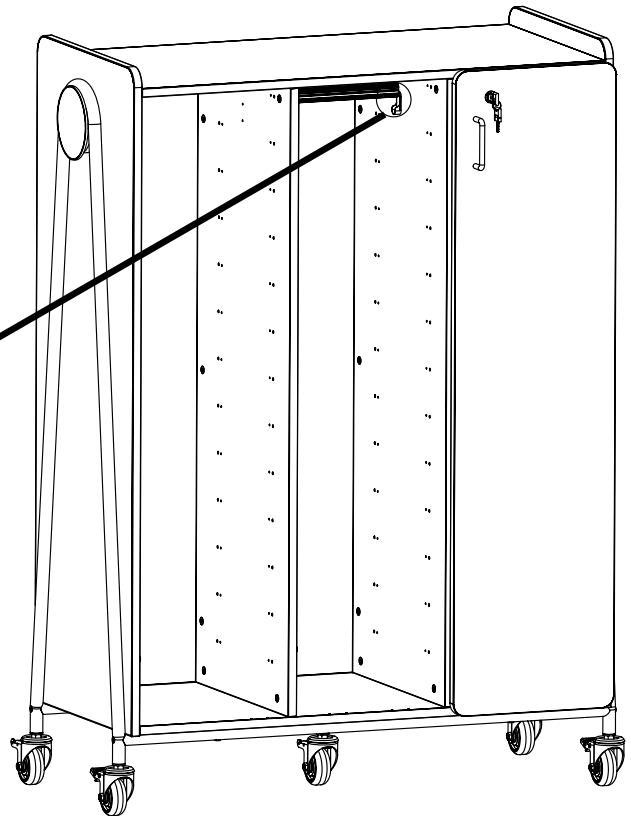
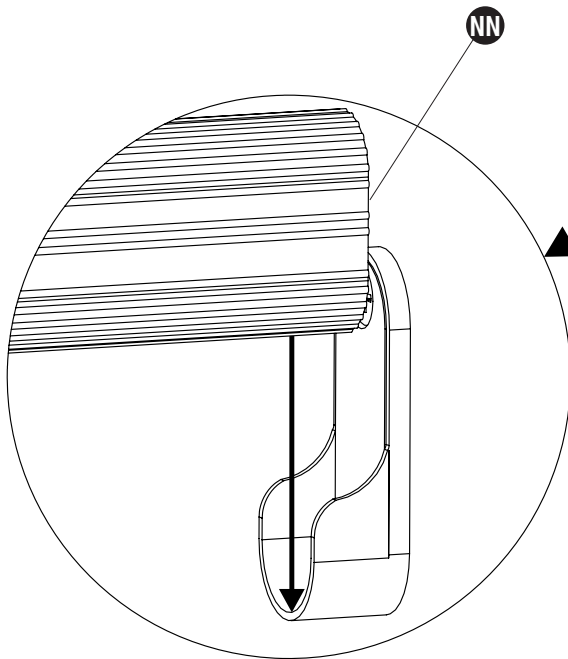

Step only for Models 3907/3908 if wardrobe bar is ordered.

Pas seulement pour les modèles 3907/3908 si la barre d'armoire est commandée.

Paso solo para los modelos 3907/3908 si se solicita la barra de guardarropa.

30 QQ (8)

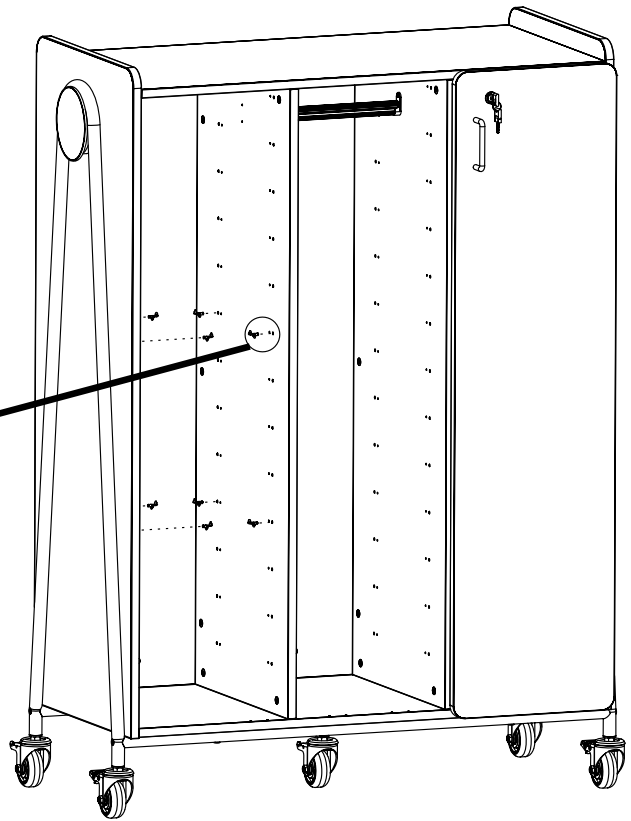
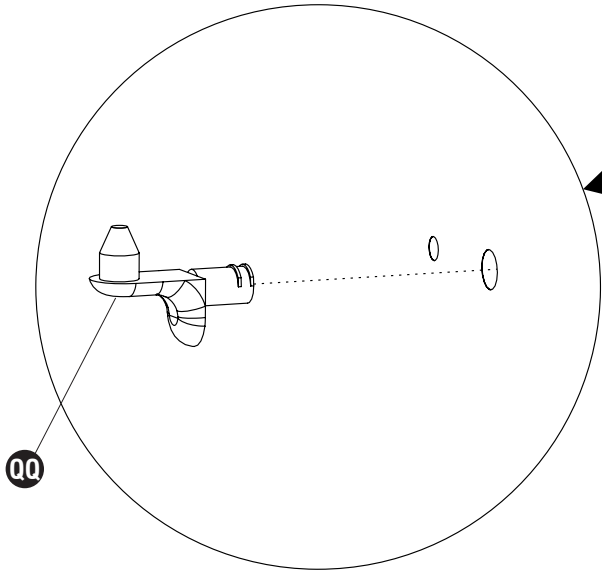
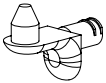

Step only if shelves are ordered.
Étape seulement si les étagères sont commandées.
Paso solo si se ordenan estantes.

31 00 (2)

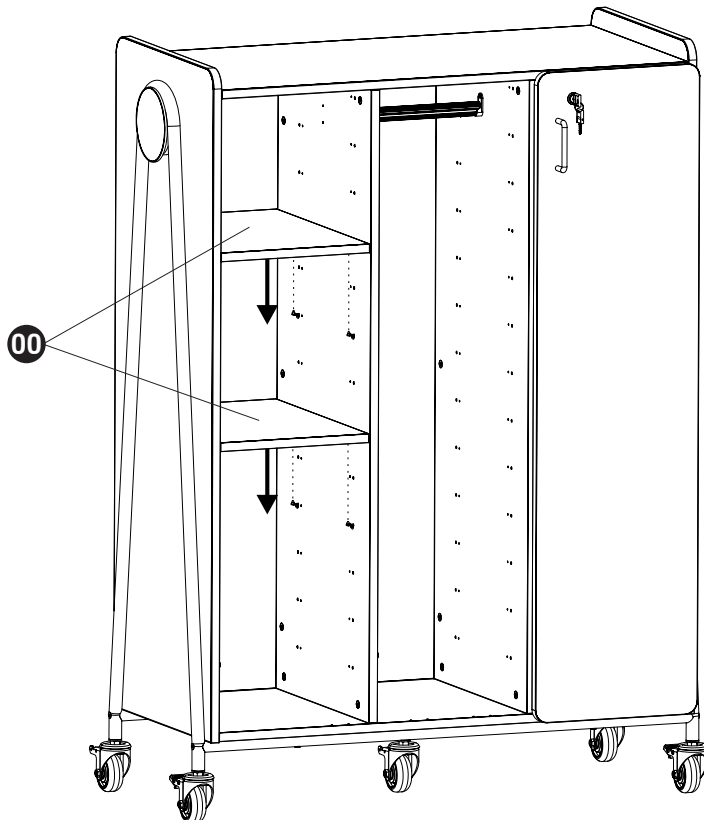
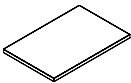

Step only if shelves are ordered.
Étape seulement si les étagères sont commandées.
Paso solo si se ordenan estantes.