

**SAFCO**<sup>®</sup>

an LDI Company  
Minneapolis, MN 55428  
www.safcoproducts.com

**Instructions**  
**INSTRUCTIONS**  
**INSTRUCCIONES**

**1702**  
**Hospitality Base Cabinet; Two Door**  
*Cabinet de Bas Hospitalité; Deux Portes*  
*Gabinete Base para Hostelería; Dos Puertas*

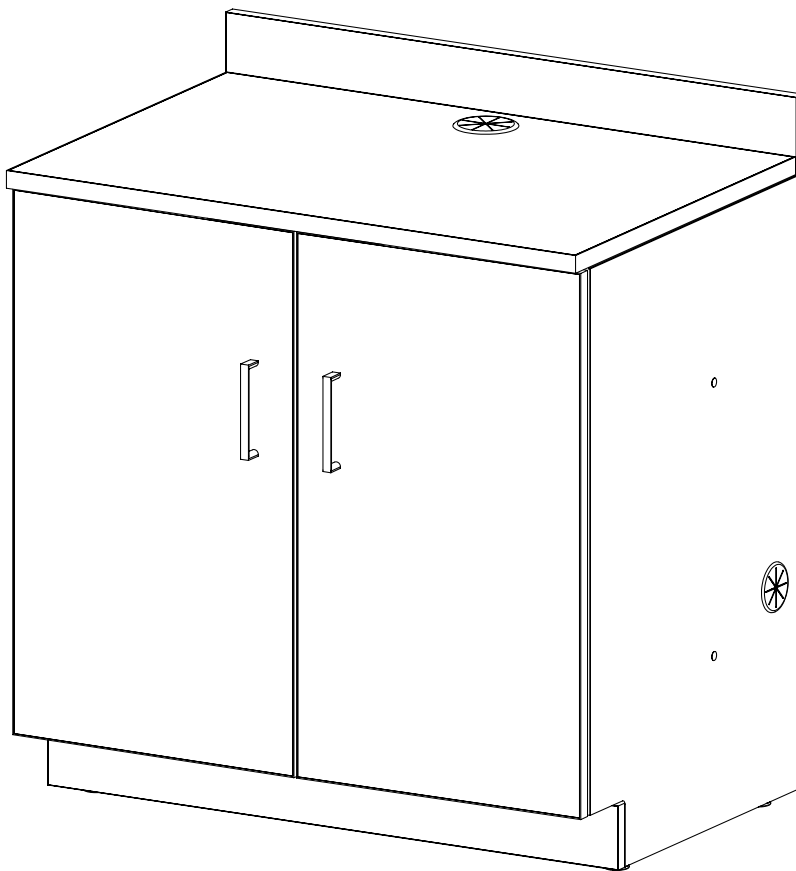

**PRODUCT WARRANTY** is available online at: [www.safcoproducts.com](http://www.safcoproducts.com)

• LA GARANTIE DU PRODUIT est  
disponible sur l'Internet : [www.safcoproducts.com](http://www.safcoproducts.com)

• LA GARANTÍA DEL PRODUCTO está  
disponible en la Internet: [www.safcoproducts.com](http://www.safcoproducts.com)

For questions or concerns, please call **1-888-971-6225**  
available Monday-Friday 7:30 AM to 5:00 PM (Central Time) (English-speaking operators)

Si vous avez des questions pour poser ou les préoccupations  
pour exprimer, connecter au **1-888-971-6225**  
de 7H30 à 17H00 (Heure centrale) (Opérateurs de langue anglaise)

Si usted tiene preguntas o preocupaciones,  
por favor llame **1-888-971-6225**  
de 7:30 AM a 5:00 PM (Hora Central) (Operadores que hablan inglés)

**TOOLS REQUIRED:** Phillips Screwdriver, Flathead Screwdriver, and Rubber Mallet  
**OUTILS REQUIS :** Tournevis cruciforme, Tournevis à Tête Plate, et Maillet en Caoutchouc  
**HERRAMIENTAS REQUERIDAS:** Destornillador Phillips, Destornillador de Cabeza Plana, y Mazo de Goma



PARTS LIST / LISTE DES PIÈCES / LISTA DE PIEZAS			
CODE / CODIGO	DESCRIPTION / DESCRIPTION / DESCRIPCIÓN	QTY. / QUANTITÉ / CANTIDAD	PART NO. / N° DE PIÈCE / NO. DE PIEZA
(A)	<b>Top Panel / Panneau Supérieur / Panel Superior</b>	1	440000004\$
(B)	<b>Bottom Panel / Panneau Du Bas / Panel Inferior</b>	1	410000019\$
(C)	<b>Left Side Panel / Panneau Latéral Gauche / Panel Lateral Izquierdo</b>	1	420000013\$
(D)	<b>Right Side Panel / Panneau Latéral Droit / Panel Lateral Derecho</b>	1	420000014\$
(E)	<b>Lower Back Panel / Panneau Arrière Inférieur / Panel Trasero Inferior</b>	1	410000017\$
(F)	<b>Upper Back Panel / Panneau Arrière Supérieur / Panel Trasero Superior</b>	1	410000018\$
(G)	<b>Toe Kick Panel / Panneau Coup de Pied D'orteil / Panel de Patada del Dedo del Pie</b>	1	420000015\$
(H)	<b>Cross Support Panel / Panneau de Support Croisé / Panel de Soporte Cruzado</b>	1	410000021\$
(I)	<b>Backsplash Panel / Panneau de Dossieret / Panel de Protector Contra Salpicaduras</b>	1	440000006\$
(J)	<b>Left Door / Porte Gauche / Puerta Izquierda</b>	1	435000003\$
(K)	<b>Right Door / Porte Droite / Puerta Derech</b>	1	435000004\$
(L)	<b>Shelf / Étagère / Estante</b>	2	445000008\$

§Note: When corresponding about parts, be sure to state color: Asian Night/Black (AN), Mahogany (MH), Vanilla Stix (VS).

§Noter: Quand correspondre au sujet de parties, soyez sûr d'affirmer la couleur: Nuit Asiatique/Noir (AN), Acajou (MH), Vanille Stix (VS).

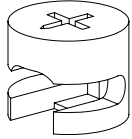
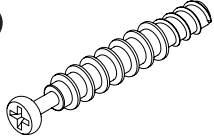
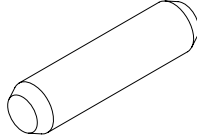
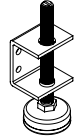
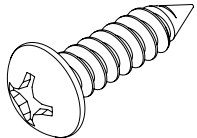
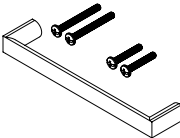
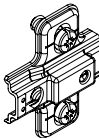
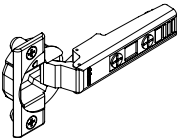
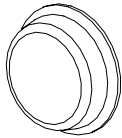
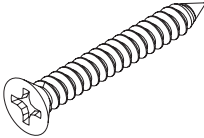
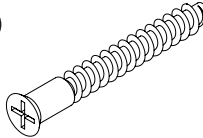
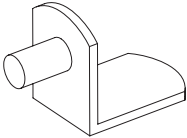
§Note: Al corresponder sobre las piezas, esté seguro declarar el color: Noche asiática/Negro (AN), Caoba (MH), Stix de Vainilla (VS).

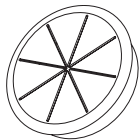
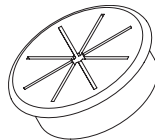
Hardware Pack / Paquet Matériel / Paquete Material: 900000350			
<p><b>M</b></p>  <p><b>Cam 15mm X 12.3mm</b> Came 15mm X 12.3mm Leva 15mm X 12.3mm</p> <p>Qty. / Qté. / Cant. 18 920000310</p>	<p><b>N</b></p>  <p><b>Cam Post 44.5mm</b> Poteau de Came 44.5mm Poste de Leva 44.5mm</p> <p>Qty. / Qté. / Cant. 18 920000504</p>	<p><b>O</b></p>  <p><b>Wood Dowel 8mm X 30mm</b> Cheville en Bois 8mm X 30mm Pasador de Madera 8mm X 30mm</p> <p>Qty. / Qté. / Cant. 22 920000309</p>	<p><b>P</b></p>  <p><b>Leveler Assembly</b> Assemblage du Niveleur Ensamblaje del Nivelador</p> <p>Qty. / Qté. / Cant. 4 960000004</p>
<p><b>Q</b></p>  <p><b>Screw #8 X 1/2"</b> Vis #8 X 1/2" Tornillo #8 X 1/2"</p> <p>Qty. / Qté. / Cant. 16 905000470</p>	<p><b>R</b></p>  <p><b>Handle &amp; Screws #8-32 X 1" &amp; 1/2"</b> Poignée avec Vis #8-32 X 1" &amp; 1/2" Mango con Tornillos #8-32 X 1/2"</p> <p>Qty. / Qté. / Cant. 2 925000001</p>	<p><b>S</b></p>  <p><b>Hinge Mounting Plate</b> Plaque de Montage de Charnière Placa de Montaje de Bisagra</p> <p>Qty. / Qté. / Cant. 4 920000569</p>	<p><b>T</b></p>  <p><b>Hinge Arm</b> Bras de Charnière Brazo de Bisagra</p> <p>Qty. / Qté. / Cant. 4 920000568</p>
<p><b>U</b></p>  <p><b>Bumper</b> Pare-chocs Parachoque</p> <p>Qty. / Qté. / Cant. 4 905000434</p>	<p><b>V</b></p>  <p><b>Screw #8 X 1 1/4"</b> Vis #8 X 1 1/4" Tornillo #8 X 1 1/4"</p> <p>Qty. / Qté. / Cant. 2 905000060</p>	<p><b>W</b></p>  <p><b>Screw 5mm X 40mm</b> Vis 5mm X 40mm Tornillo 5mm X 40mm</p> <p>Qty. / Qté. / Cant. 8 905000439</p>	<p><b>X</b></p>  <p><b>Shelf Bracket</b> Support D'étagère Soporte para Estantes</p> <p>Qty. / Qté. / Cant. 8 920000050</p>

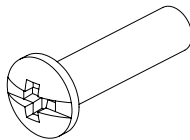
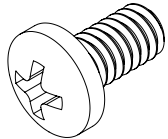
<p><b>Y</b></p>  <p><b>Grommet 80mm</b> Oeillet 80mm Ojal 80mm</p> <p>Qty. / Qté. / Cant. 1 920000057</p>	<p><b>Z</b></p>  <p><b>Grommet 60mm</b> Oeillet 60mm Ojal 60mm</p> <p>Qty. / Qté. / Cant. 2 920000056</p>	<p><b>AA</b></p>  <p><b>Hole Plug</b> Bouchon de Trou Tapón de Agujero</p> <p>Qty. / Qté. / Cant. 4 920000550</p>	<p><b>BB</b></p>  <p><b>Binding Barrel 1/4"-20 X 1 1/4"</b> Baril de Reliure 1/4"-20 X 1 1/4" Barril de Unión 1/4"-20 X 1 1/4"</p> <p>Qty. / Qté. / Cant. 2 905000477</p>
<p><b>CC</b></p>  <p><b>Screw 1/4"-20 X 1/2"</b> Vis 1/4"-20 X 1/2" Tornillo 1/4"-20 X 1/2"</p> <p>Qty. / Qté. / Cant. 2 7005</p>			

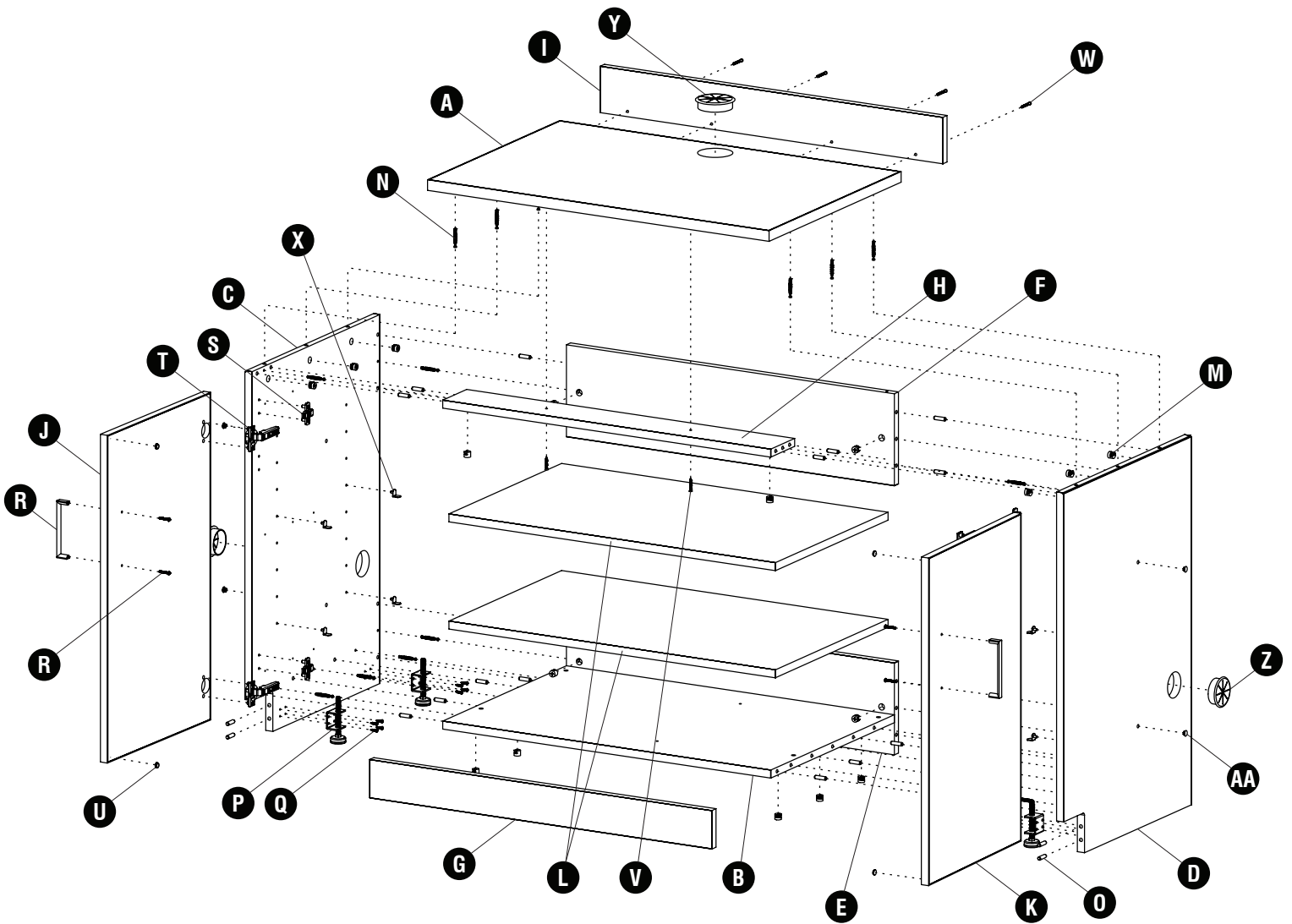

**1** **N** (6)

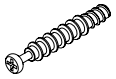

Unused holes.  
*Trous inutilisés.*  
Agujeros no utilizados.

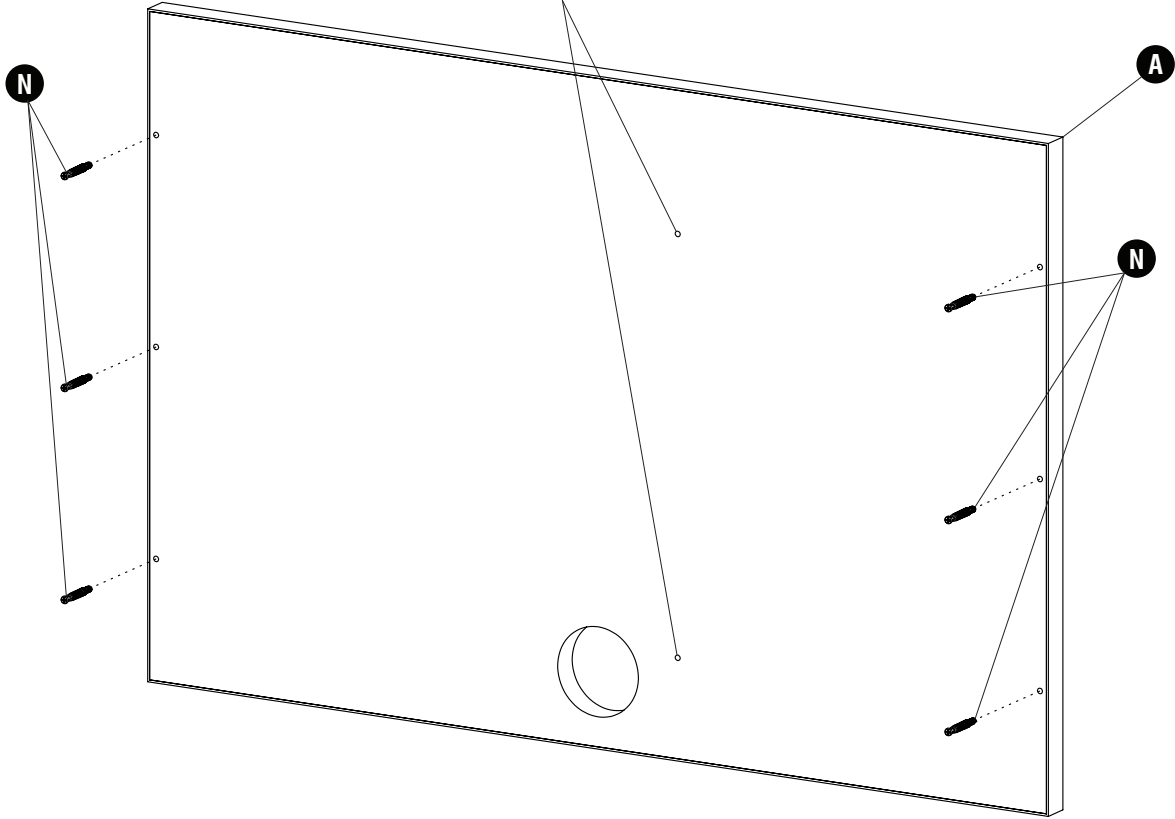



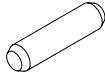

**2** **M** (6) **O** (6)

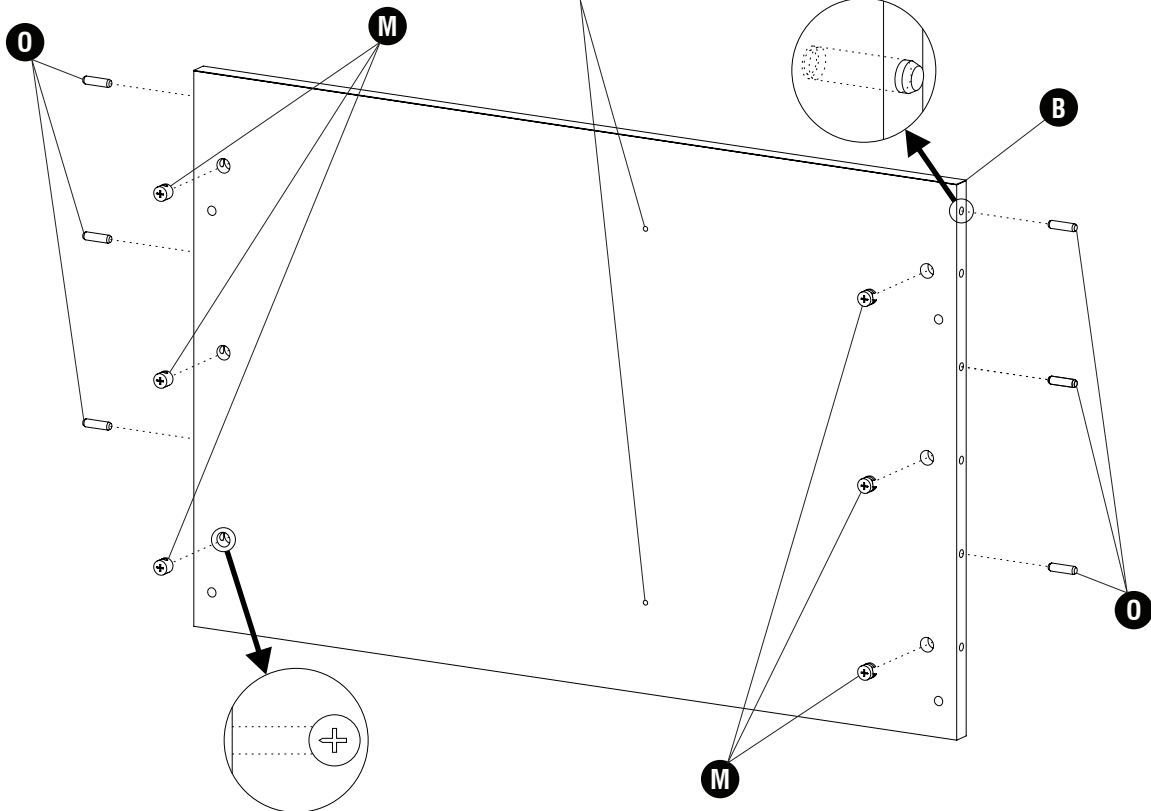

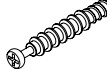
Unused holes.  
*Trous inutilisés.*  
Agujeros no utilizados.

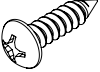

- 3** **M**  (6) **N**  (12) **O**  (4) **P**  (4) **Q**  (16) **S**  (4)

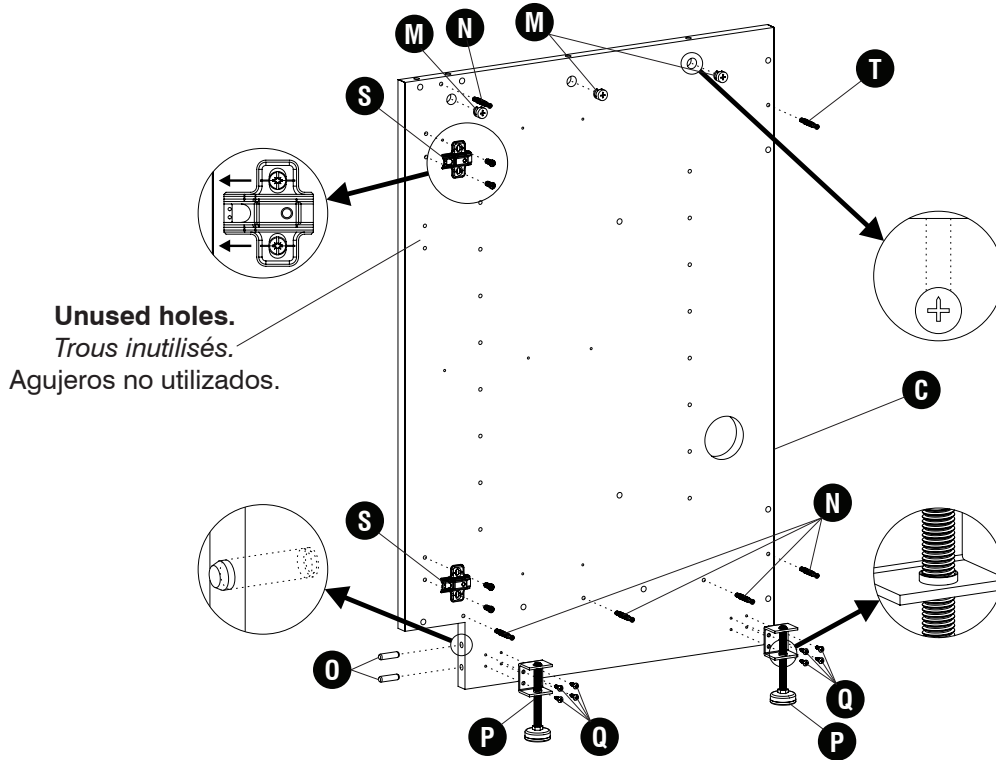

**Install leveler bracket with the threads at the bottom. Repeat step for the right panel.**

*Installer le support de niveleur avec les filetages en bas. Répétez l'étape pour le panneau de droite.*

Instale el soporte del nivelador con las roscas en la parte inferior. Repita el paso para el panel derecho.

- 4** **M**  (2) **O**  (4)

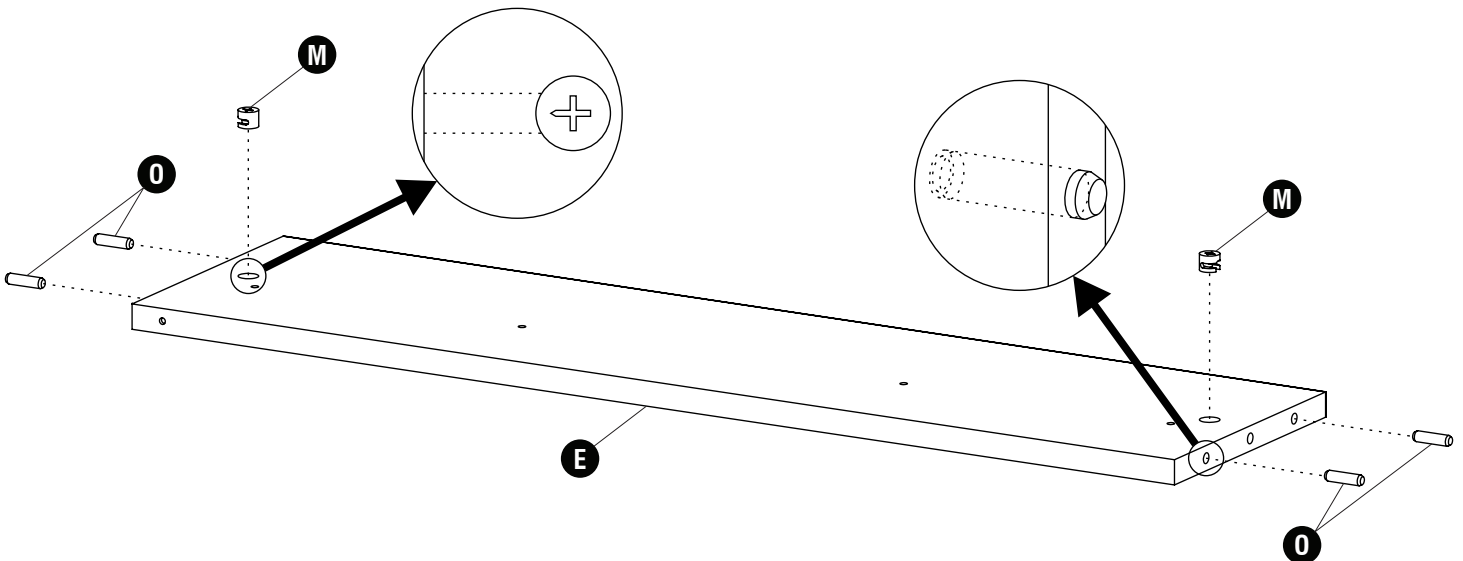

5 M  (2) 0  (4)

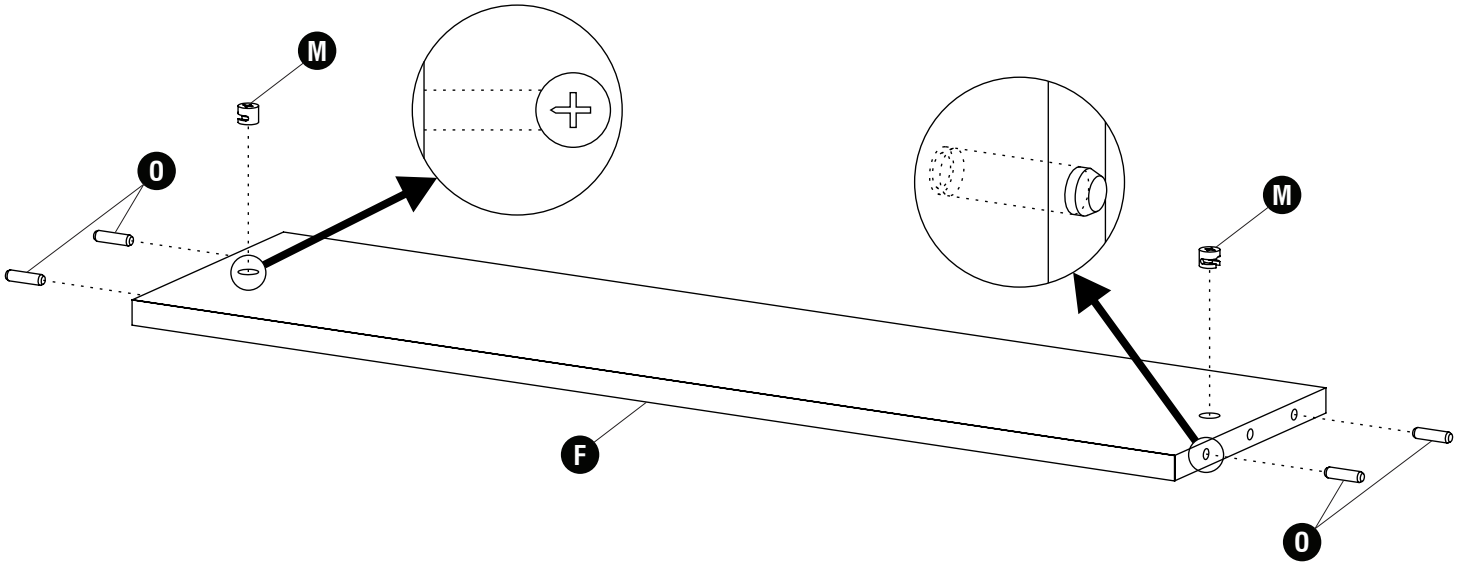

6 M  (2) 0  (4)

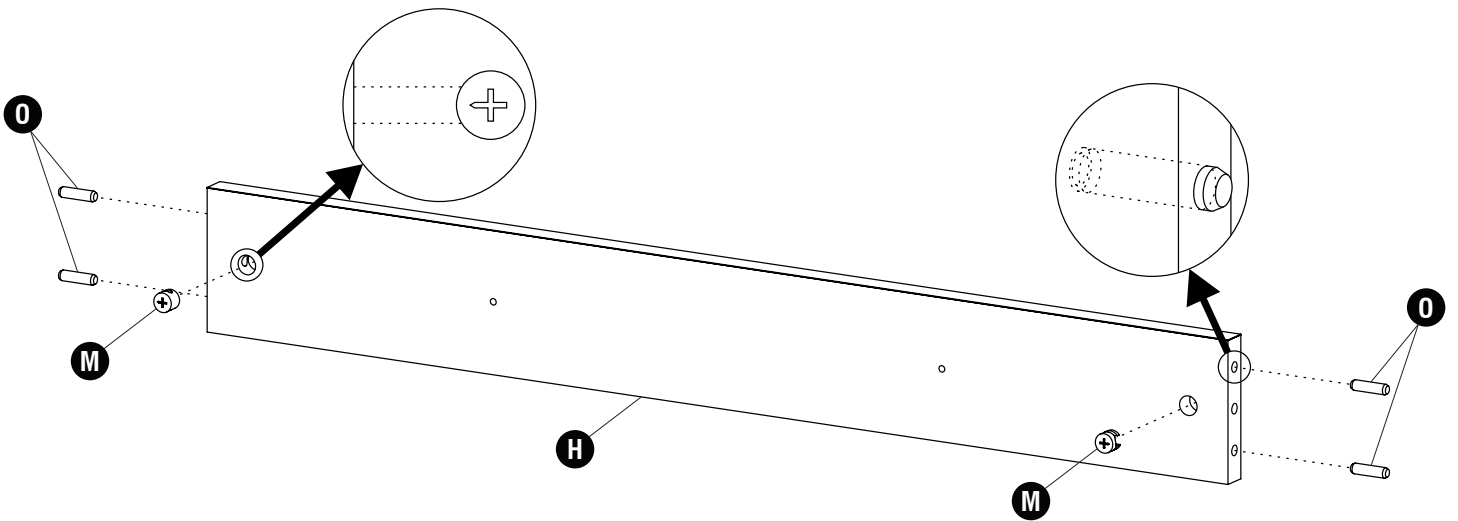

**7** **R** (2) **T** (4) **U** (4)

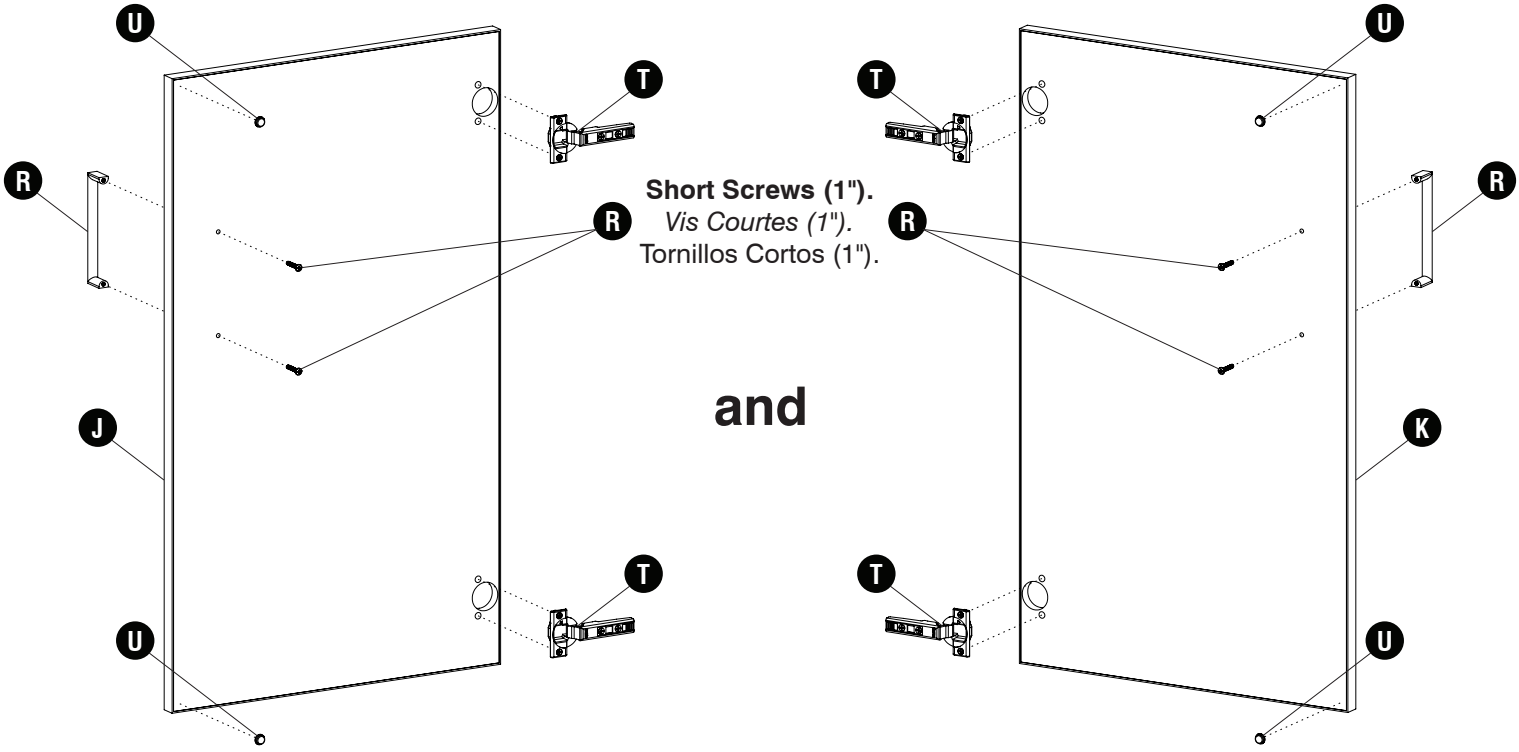

**Use a rubber mallet to fully seat hinge arms into the door.**

*Utiliser un maillet en caoutchouc pour insérer complètement les bras de charnière dans la porte.*  
*Utilice un mazo de goma para asentar completamente los brazos de las bisagras en la puerta.*

**8**

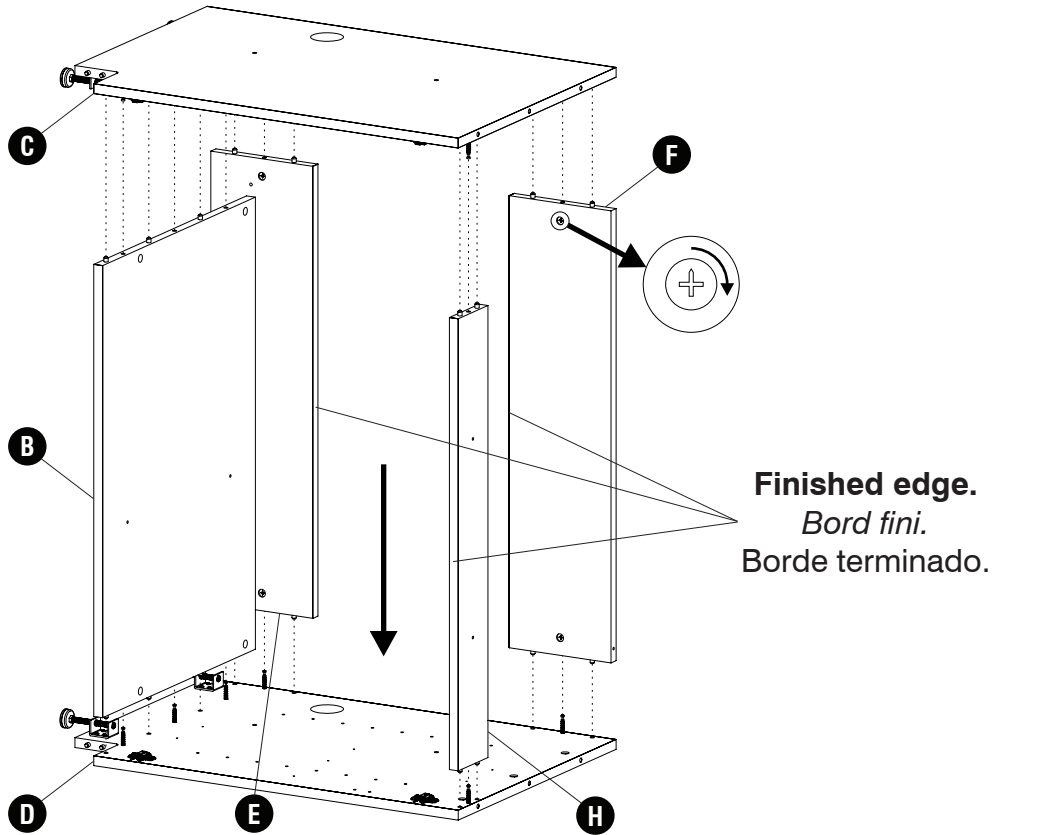

**Be sure to tighten all the cams.**  
*Assurez-vous de serrer toutes les cames.*  
*Asegúrese de apretar todas las levas.*

9

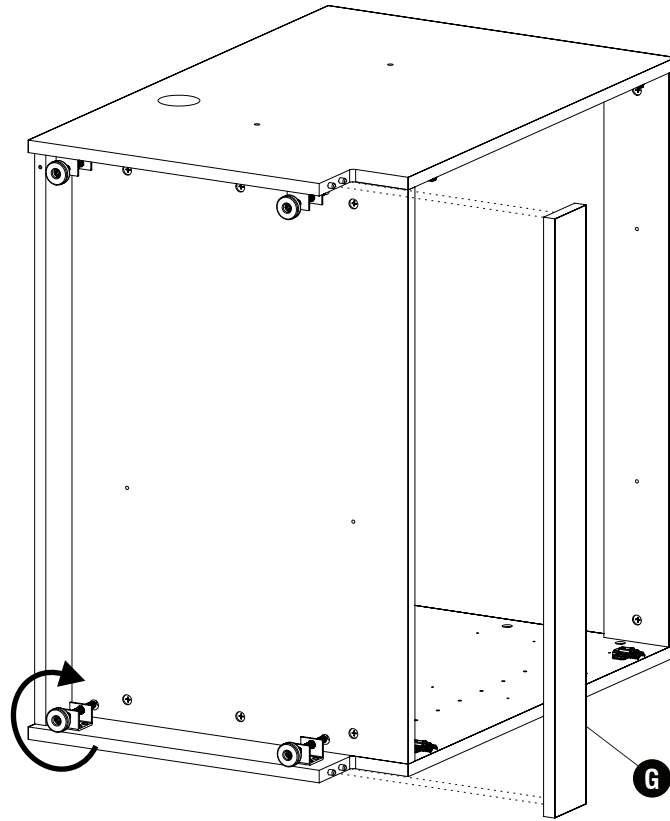

**Screw in levelers all the way before turning assembly upright.**

*Visser complètement les niveleurs avant de remettre l'assemblage à la verticale.*

*Atornille los niveladores completamente antes de colocar el conjunto en posición vertical.*

10 V (2)

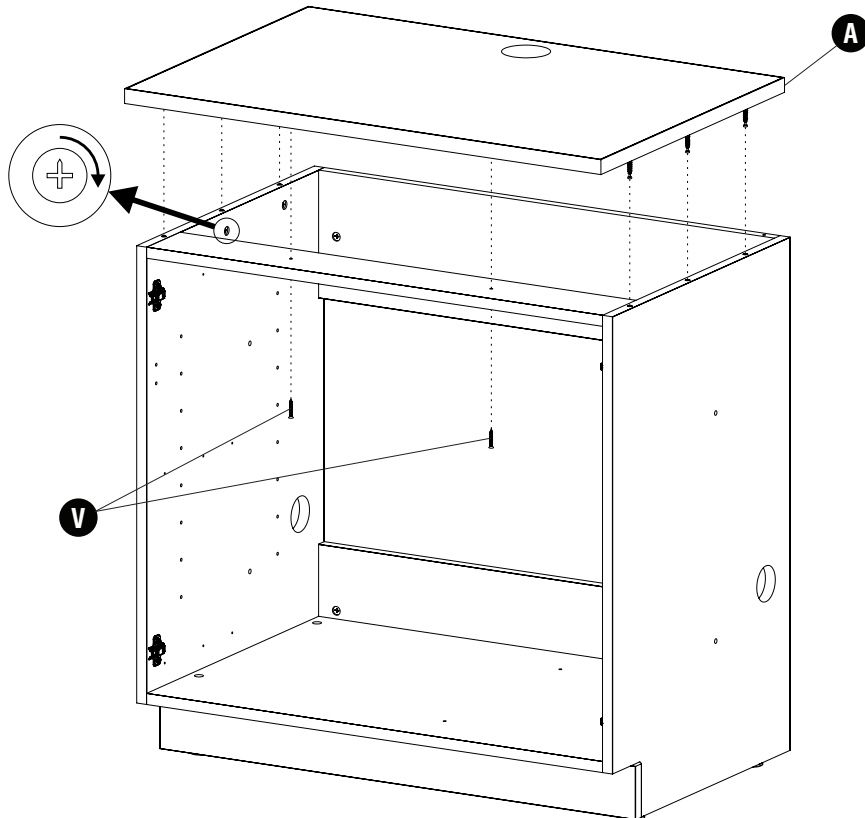

**Be sure to tighten all the cams.**

*Assurez-vous de serrer toutes les cames.*

*Asegúrese de apretar todas las levas.*



11 W

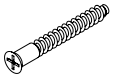

(8)

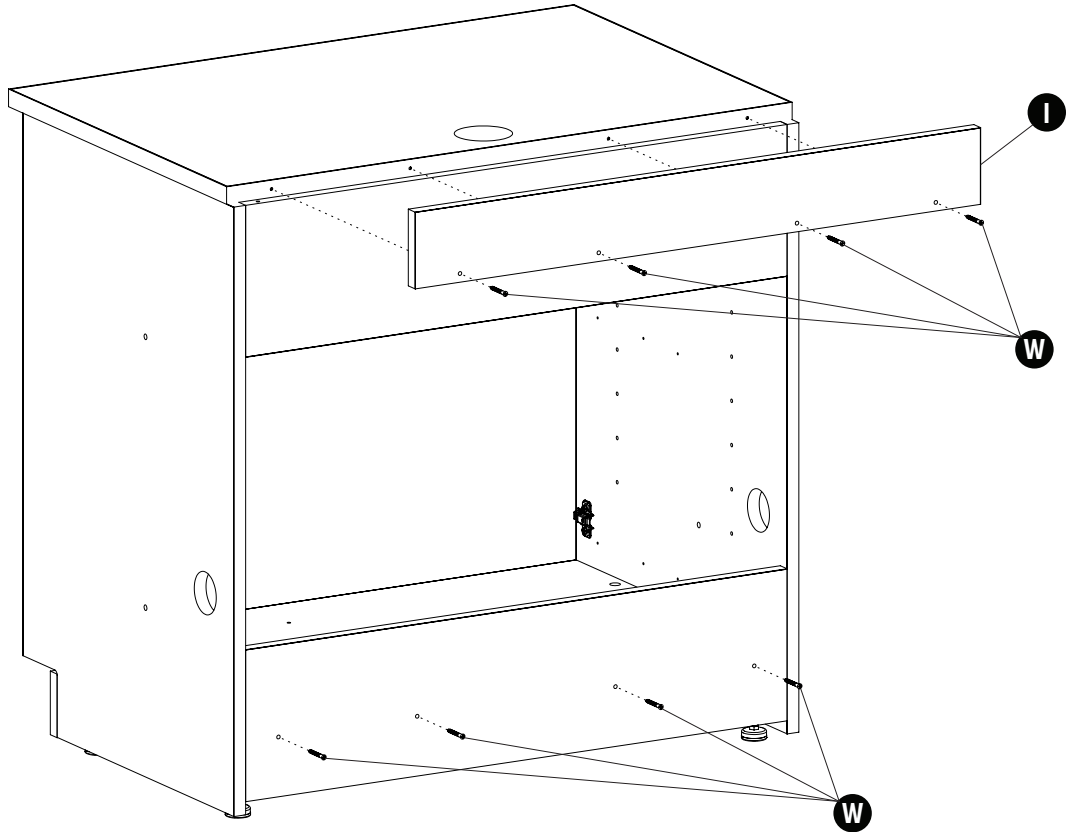

12 X

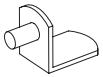

(8)

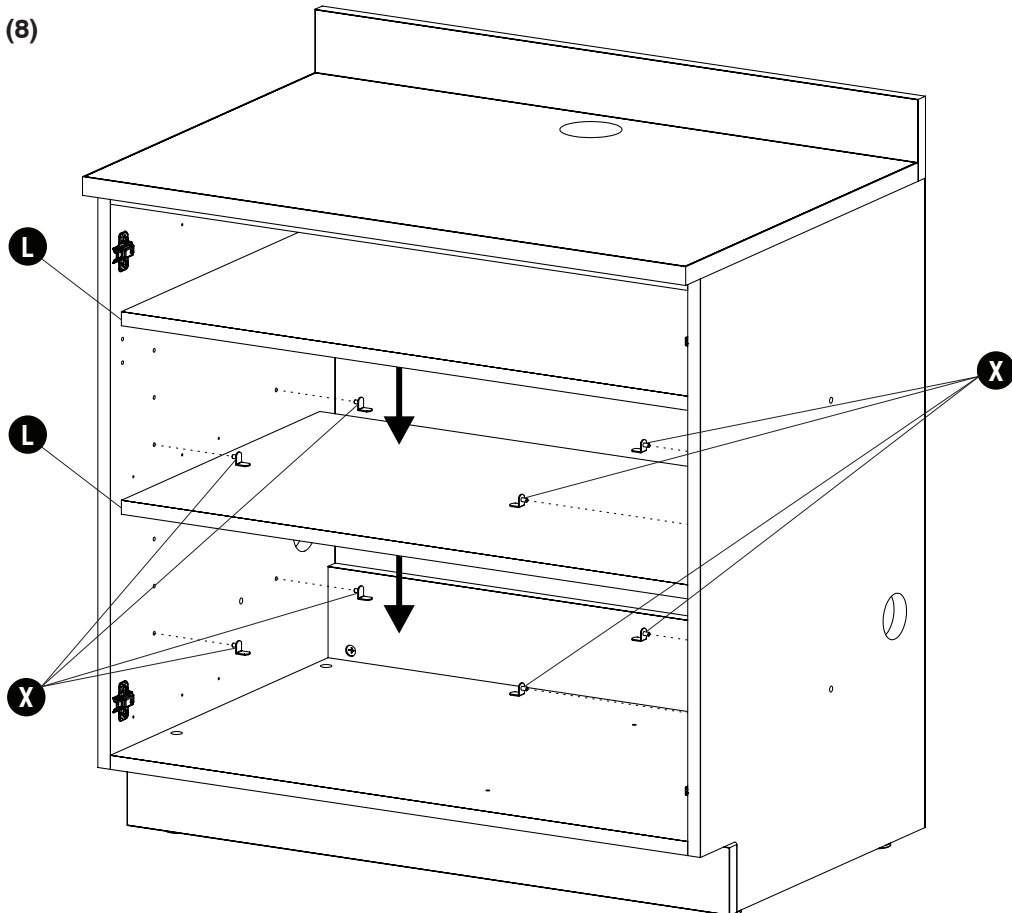

13

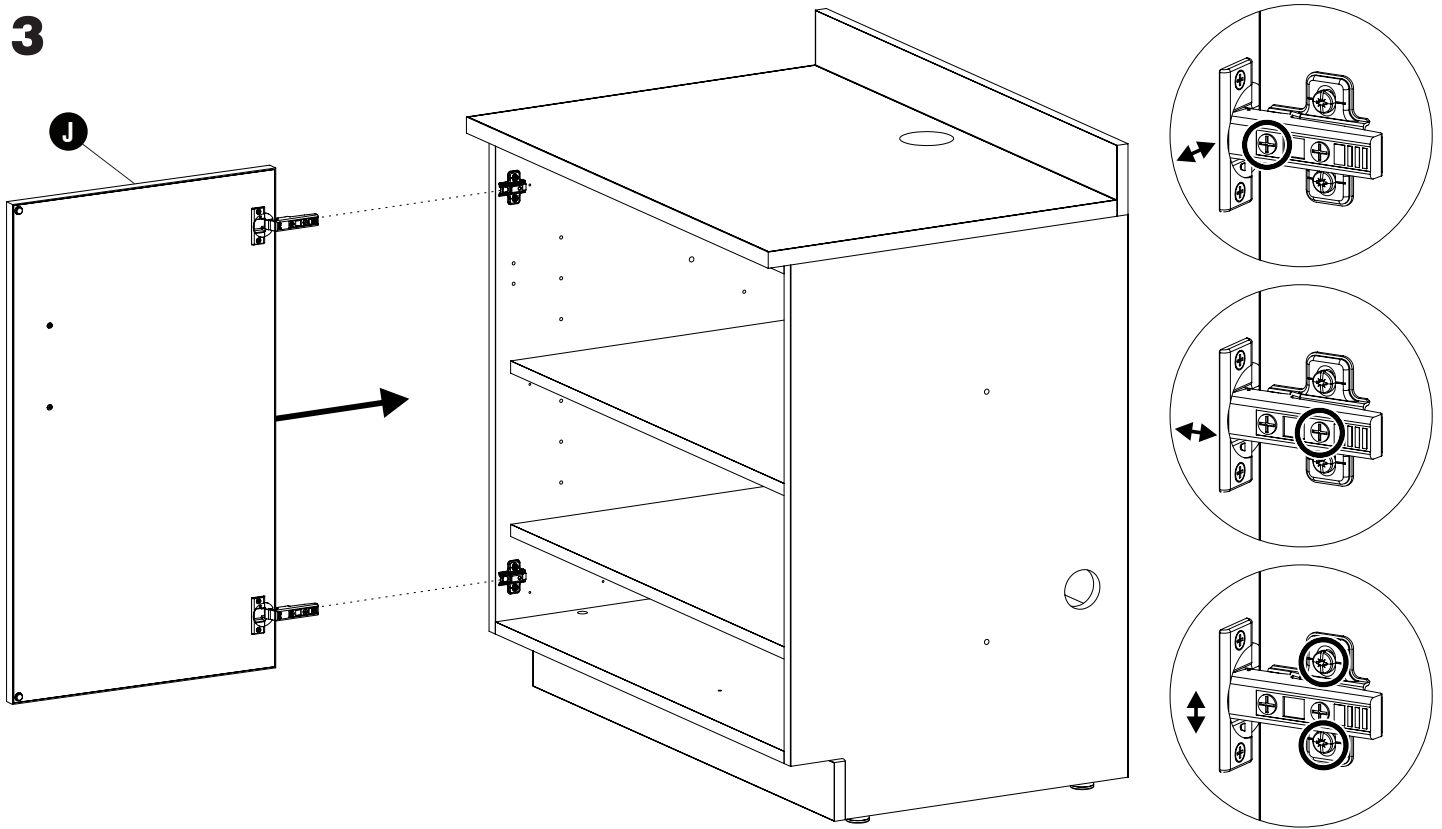

**Adjust hinges by tightening and loosening screws accordingly. Repeat step for the other door.**  
*Ajustez les charnières en serrant et en desserrant les vis en conséquence. Répétez l'étape pour l'autre porte.*  
*Ajuste las bisagras apretando y aflojando los tornillos según corresponda. Repita el paso para la otra puerta.*

14

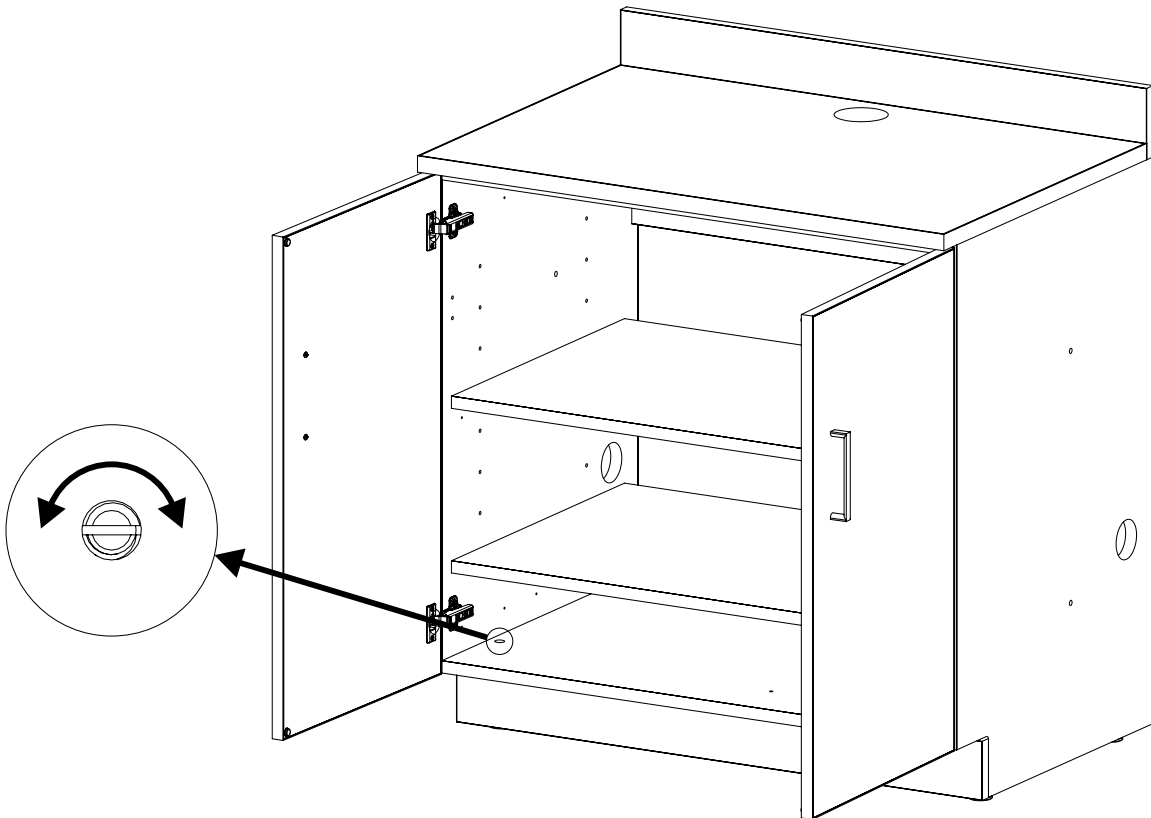

**Use a flathead screwdriver to adjust leveler height and to level the cabinet.**  
*Utiliser un tournevis à tête plate pour régler la hauteur du niveleur et pour niveler l'armoire.*  
*Use un destornillador de punta plana para ajustar la altura del nivelador y nivelar el gabinete.*

**15** Y (1) Z (2) AA (4)

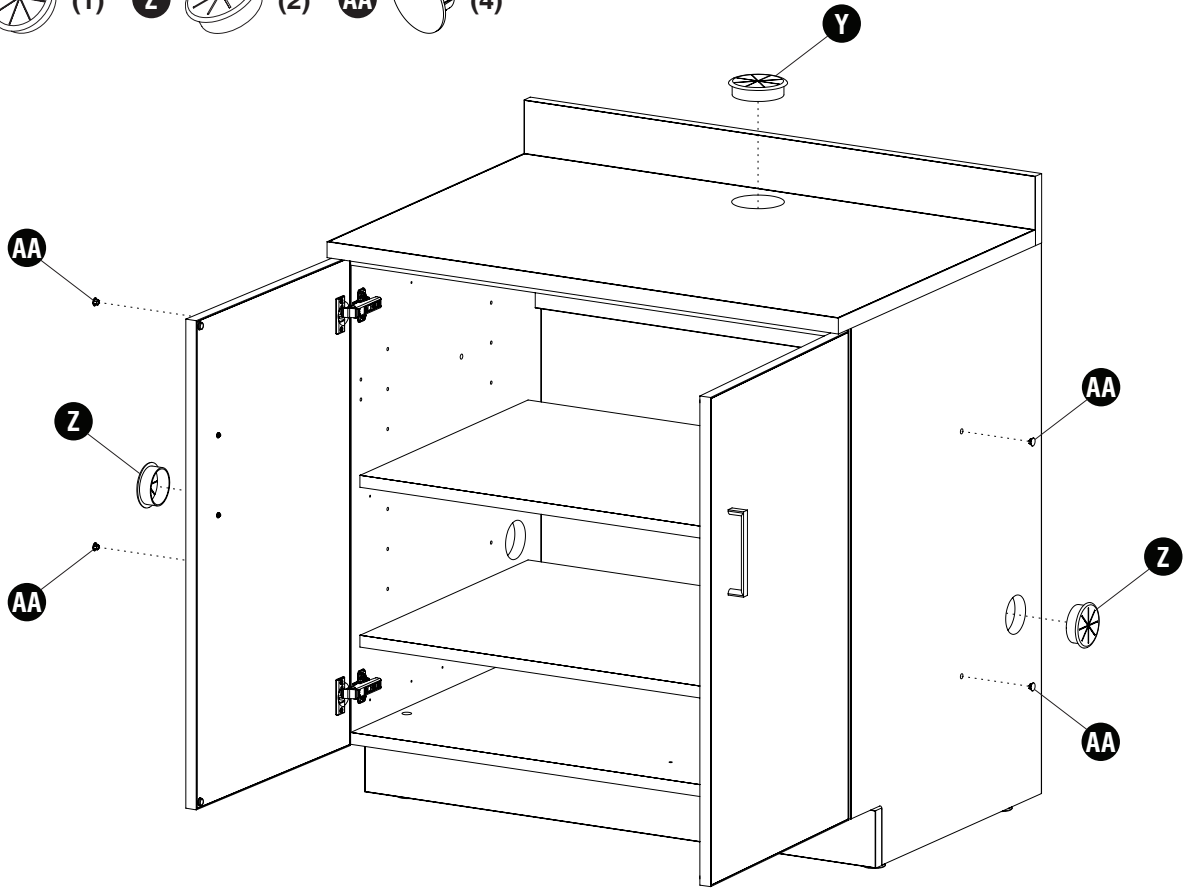

**16** Y (2) Z (4) AA (4) BB (2) CC (2)

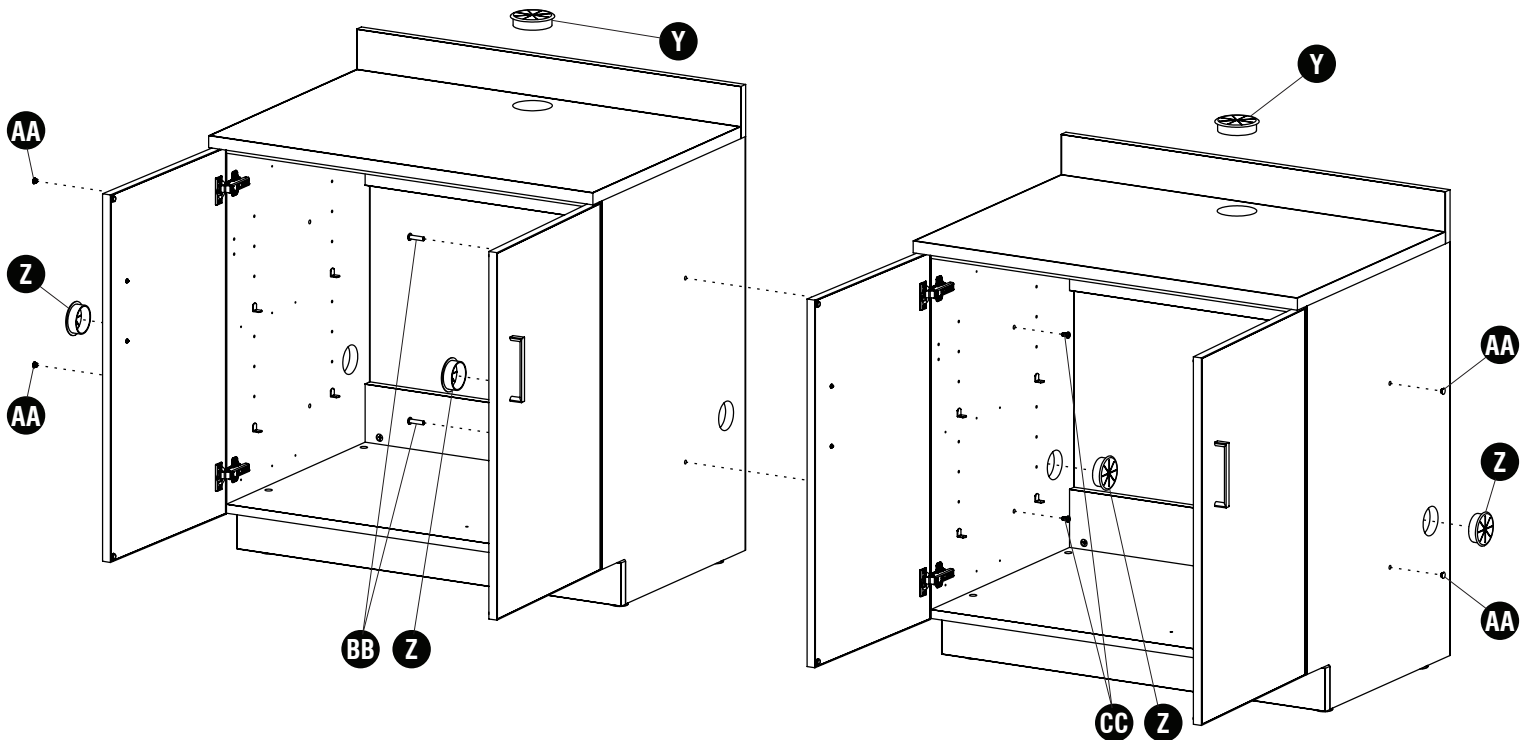

**Step only for ganging multiple cabinets together.**  
*Étape uniquement pour regrouper plusieurs armoires.*  
**Paso solo para agrupar varios gabinetes juntos.**