

ASSEMBLY INSTRUCTIONS for DUAL COLUMN 2 and 3 STAGE BASES

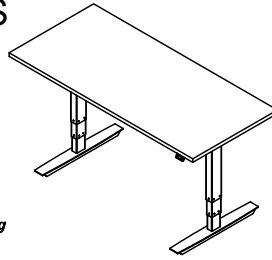
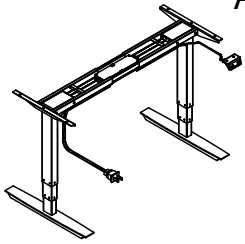

NOTE: Column Assemblies are heavy. Use care to avoid dropping column or allowing column assembly to fall during assembly or damage to internal glide system may occur!

NOTE: Please count and inspect all pieces before disposing of any carton or packing materials.

COMPONENTS: When ordering components, specific size information may be required. Contact a Mayline Customer Service Representative. 1-800-822-8037

REF. #	QTY.	DESCRIPTION	PART No.
1	2	LIFT ACTUATOR	-
2	2	FOOT w/LEVELERS	5122F2S (22" 2 Stage) - 5122FS (22" 3 Stage) 5126F2S (26" 2 Stage) - 5126FS (26" 3 Stage)
3	2	ACTUATOR FRAME	-
4	2	ADJ. CROSS BAR	-
5	2	TOP SUPPORT BRKT	A9284S
6	1	CONTROL BOX	Z550 (2 Stage) - Z551 (3 Stage)
7	1	STD. SWITCH	523SC
8	2	CABLE MANAGEMENT TRAY	-
9	1	POWER CORD	-

****OPTIONAL MEMORY SWITCH - 523MC**

HARDWARE BAG (For any missing components order PART No. A9292)

REF. #	QTY.	SPARE	DESCRIPTION	
E1	8	2	M6 x 15mm MACHINE SCREW LOCK WASHER FLAT WASHER	
E2	10	1	5mm x 20mm WOOD SCREW	
E3	1		4mm HEX WRENCH	
E4	1		5mm HEX WRENCH	
E5	4	1	M6 x 33mm MACHINE SCREW	

REPLACEMENT LEVELER
QTY 1
PART# Q714



OPTIONAL CASTERS - QTY 4
2 LOCKING/2 NON-LOCKING
PART# Q715



1. Remove the Actuator/Frame Assembly (Parts 1,3,4) from the carton and place on a clean flat surface with the frame down.
2. Carefully unfold the Lift Actuators (1) to the vertical position.

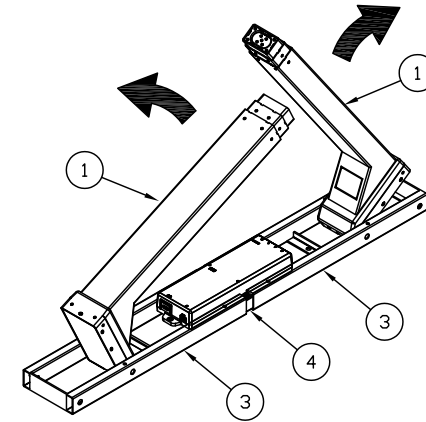

3. Insert Top Support Brackets (5) into each side of Frame Assembly (3).
4. Separate Actuator Frames (3) from Adj Cross Bars (4) enough to expose Pre-Installed Screws. Using Screws (E5) and Hex Wrench (E4), lock the Actuator Frame (3) to Lifting column (1). Tighten all Screws.

****IMPORTANT: TIGHTEN THE TWO PRE-INSTALLED SCREWS AT THE FRONT OF EACH ACTUATOR. SEE ILLUSTRATION.**

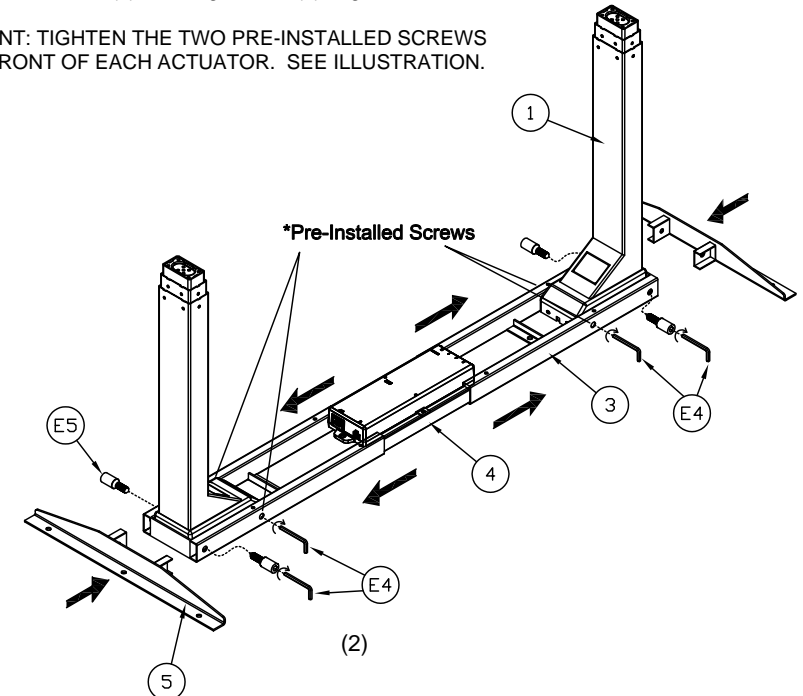

5. Place Table Top down on a clean, flat, non-abrasive surface. Place Actuator/Frame assembly in mounting location on top. Note: Use pilot holes and Top Support Brkt as a guide.

Note: Cross Bar adjustment will be required. Adjust Cross Bars (4) so they are approximately centered in the frame.

6. Attach Actuator Frames (3) and Top Support Brackets (5) to Top using Screws (E2). Do Not Over-tighten.

7. Attach Foot (2) to Actuator using Screws (E1) and Wrench (E3). Four req'd per Foot.

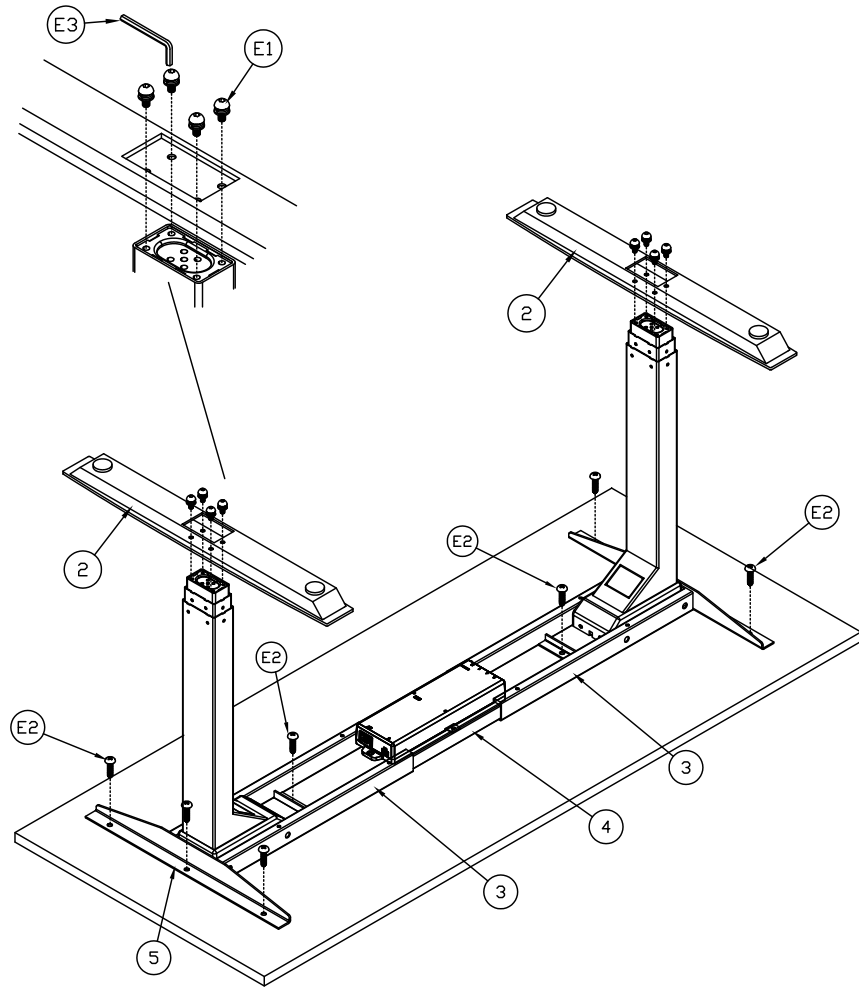

(3)

8. Position Switch (7) at desired location on front edge of top, and fasten with Screws (E2)

9. Position Cable Management Tray (8) on the frame, and fasten using Screws (E1) and wrench (E3).

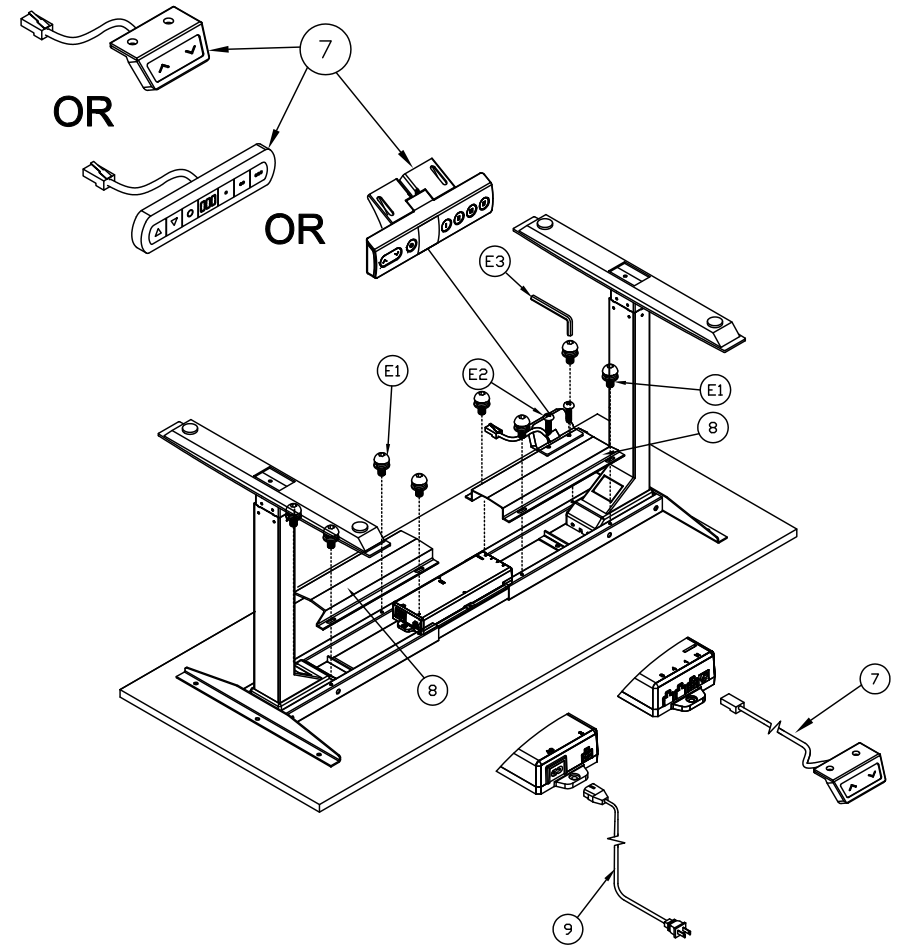



(4)

10. Carefully plug Motor Cables from Lift Actuators, Switch Cord (7), and Power Cord (9) into matching ports on Control Box (6). Use the Diagram below as a guide.

11. Using one person per side, Carefully rotate table onto the base.

12. Plug power cord into outlet and proceed with Switch Initialization. See Below

 Make sure no obstacles are in the desk's path.
Make sure the desktop is not touching any walls. 
Make sure all cords are appropriate length to accommodate the change in height.

IMPORTANT: You must INITIALIZE the desk prior to first use.

Controller Initialization- Press and hold the Down button on the controller until the desk reaches its lowest height, slightly raises, and stops. Release the down button, your desk is now ready for use. (Following the "USER MANUALS" to use your desk)

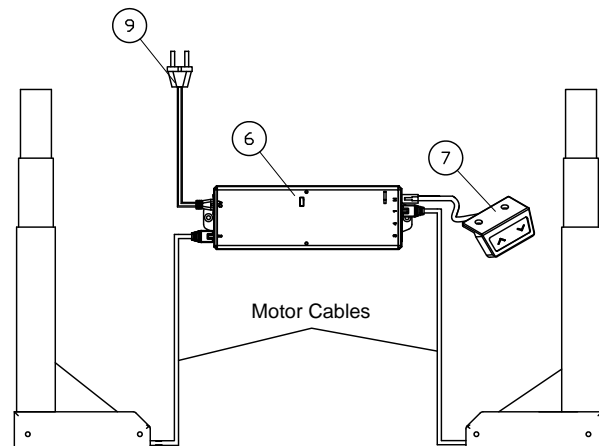

TROUBLESHOOTING

If the table is not functioning properly, it may need to be reset. Unplug the power cord for 20 seconds. Plug the power cord back in and follow the RESET procedure.

If the problems continues after the reset procedure, please contact your dealer.

If the height differential between the legs exceeds 1.5", stop the reset procedure and contact you dealer.