

MasterFile 2



Gas cylinders assist raising of lid; prevent lid from accidental closure.

Attractive brushed aluminum easy-open handles.

Adjustable sheet holder knobs (included), provide convenient storage for active documents.

Double wall construction with insulating liner for extra strength and quiet operation.

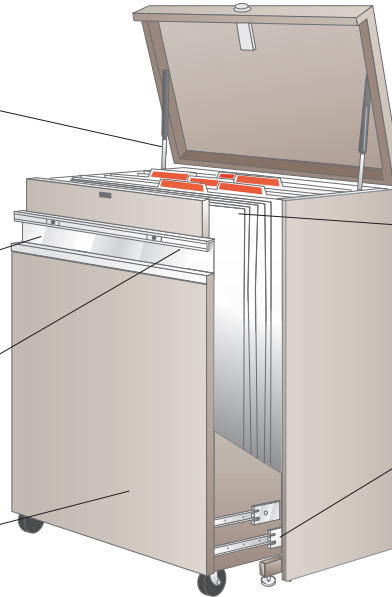

Moisture and dust seal.

Pins and posts located on 6½" centers for maximum support and multiple size filing.

Raised, full suspension drawer moves smoothly over any floor surface, provides toe space to minimize reach for last document. Stabilizer legs adjust for load compression.

MASTERFILE 2

- capacity 1,600, 3-mil active documents in one unit
- each document attached to self-adhesive, pre-punched carrier strips (order separately)
- hung vertically from pins and posts on 6½" centers
- design helps eliminate fingerprints and tears
- locking mechanism with dust and moisture seal
- carrier strips sold separately

CARRIER STRIPS

- self-adhesive
- can be cut into 100 - 24" strips, 80 - 30" strips or 50 - 48" strips
- pre-printed identification blocks for drawings
- model 6553 may be used in plan hold Masterfile 2 series files

Model	Description	Document Size W x H	W x D x H	Ship Weight
MasterFile 2				
5023AH	MasterFile 2	36 x 24"	32 x 21½ x 45"	252 lbs.
5024AH	MasterFile 2	42 x 30"	36 x 21½ x 50"	320 lbs.
5025AH	MasterFile 2	48 x 36"	56 x 21½ x 45"	393 lbs.
MasterFile 2 Accessories				
6551	Carrier Strip Film		2¼ x 217'	3 lbs.
6552	Carrier Strip Transparent		2¼ x 217'	3 lbs.
6553	Carrier Strip Transparent		2¼ x 216'	3 lbs.