

JN*****XBA**

Jurni X Base Cafe Tables

Jurni Tables de café à base X
Jurni Mesas de café base X

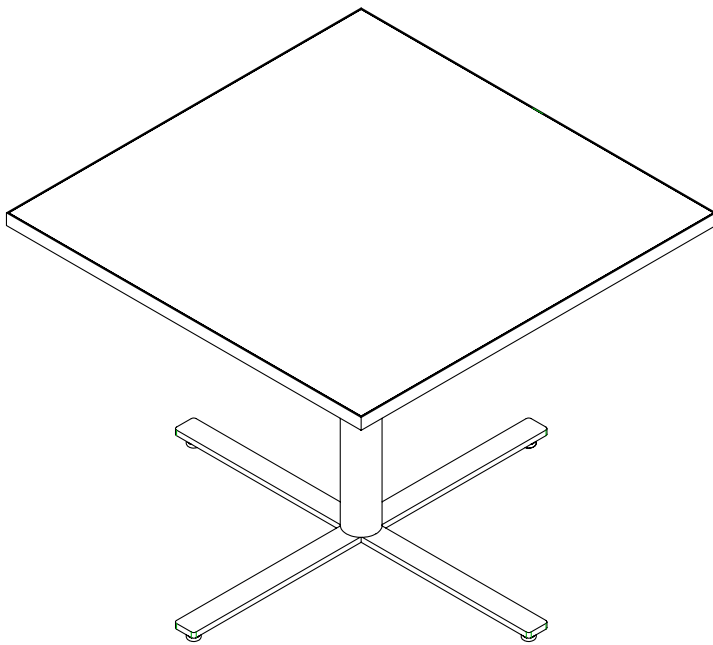

Model JN36SQNXBA29 Shown
Modèle JN36SQNXBA29 illustré
Se Muestra el Modelo JN36SQNXBA29

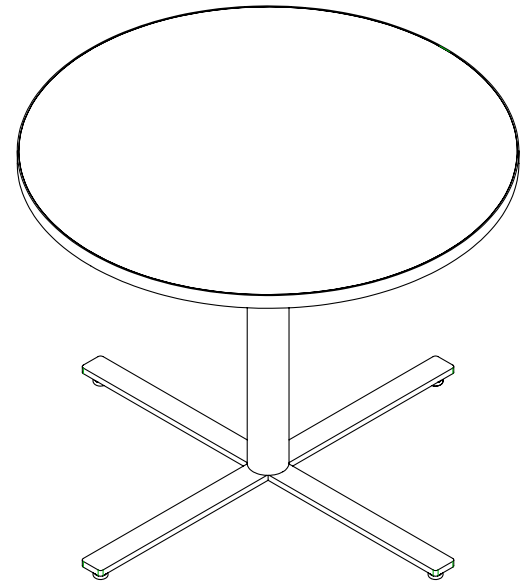

Model JN36RDNXBA29 Shown
Modèle JN36RDNXBA29 illustré
Se Muestra el Modelo JN36RDNXBA29

⚠ KEEP OUT OF REACH OF CHILDREN UNTIL ASSEMBLY IS COMPLETE, DUE TO THE PRESENCE OF SMALL OR SHARP PARTS.
ADULT ASSEMBLY REQUIRED

⚠ TENIR HORS DE PORTÉE DES ENFANTS JUSQU'À CE QUE
L'ASSEMBLAGE SOIT TERMINÉ, EN RAISON DE LA
PRÉSENCE DE PIÈCES PETITES OU TRANCHANTES.
ASSEMBLAGE ADULTE REQUIS

⚠ MANTENER FUERA DEL ALCANCE DE LOS NIÑOS HASTA QUE SE
COMPLETE EL MONTAJE, DEBIDO A LA
PRESENCIA DE PIEZAS PEQUEÑAS O AFILADAS.
SE REQUIERE MONTAJE DE ADULTOS

PRODUCT WARRANTY is available online at: **www.safcoproducts.com**

• LA GARANTIE DU PRODUIT est
disponible sur l'Internet : **www.safcoproducts.com**

• LA GARANTÍA DEL PRODUCTO está
disponible en la Internet: **www.safcoproducts.com**

For questions or concerns, please call **1-888-971-6225**
available Monday-Friday 7:30 AM to 5:00 PM (Central Time) (English-speaking operators)

Si vous avez des questions pour poser ou les préoccupations
pour exprimer, connecter au **1-888-971-6225**
de 7H30 à 17H00 (Heure centrale) (Opérateurs de langue anglaise)

Si usted tiene preguntas o preocupaciones,
por favor llame **1-888-971-6225**
de 7:30 AM a 5:00 PM (Hora Central) (Operadores que hablan inglés)

TOOLS REQUIRED: Drill with a Phillips Bit, Socket
OUTILS NÉCESSAIRES : perceuse avec un embout cruciforme, douille
HERRAMIENTAS NECESARIAS: Taladro con broca Phillips, dado

PARTS LIST / LISTE DES PIÈCES / LISTA DE PIEZAS			
CODE / CODIGO	DESCRIPTION / DESCRIPTION / DESCRIPCIÓN	QTY. / QUANTITÉ / CANTIDAD	PART NO. / N° DE PIÈCE / NO. DE PIEZA
(A)	Tabletop / <i>Dessus de Table</i> / <i>Tablerno</i> For JN36RDNXBA29 / JN36RDNXBA42 For JN42RDNXBA29 / JN42RDNXBA42 For JN36SQNXBA29 / JN36SQNXBA42 For JN42SQNXBA29 / JN42SQNXBA42	1 1 1 1	640000540\$ 640000541\$ 640000537\$ 640000538\$
(B)	X-Base / <i>Base en X</i> / <i>Base X</i>	1	620000306\$\$
(C)	Column Assembly / <i>Assemblage de la colonne</i> / <i>Montaje de columna</i> For JN36RDNXBA29 / JN42RDNXBA29 / JN36SQNXBA29 / JN42SQNXBA29 For JN36RDNXBA42 / JN42RDNXBA42 / JN36SQNXBA42 / JN42SQNXBA42	1 1	620000297\$\$ 620000298\$\$
(D)	Mounting Plate / <i>Plaque de montage</i> / <i>Placa de montaje</i>	1	620000299
(E)	Leveler 5/16"-18 / <i>Niveleur 5/16"-18</i> / <i>Nivelador 5/16"-18</i> For JN*****FXPGL (Preinstalled)	4	960000092

§Note: When corresponding about parts, be sure to state top surface and edgebanding color.

§Noter: Quand correspondre au sujet de parties, soyez sûr d'affirmer surface supérieure et couleur de la bande de chant.

§Note: Al corresponder sobre las piezas, esté seguro declarar color de la superficie superior y de los cantos.

§§Note: When corresponding about parts, be sure to state paint color.

§§Noter: Lors de la correspondance sur les pièces, assurez-vous d'indiquer la couleur de la peinture.

§§Note: Cuando corresponda sobre las piezas, asegúrese de indicar el color de la pintura.

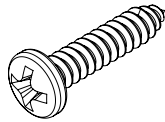
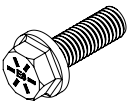
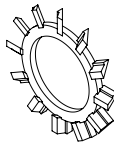
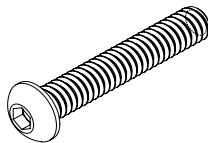
Hardware Pack / Paquet Matériel / Paquete Material: 900000461			
<div style="text-align: center; font-weight: bold; font-size: 1.2em;">F</div>  <p>Screw #12 X 1" <i>Vis #12 X 1"</i> Tornillo #12 X 1"</p> <p>Qty. / Qté. / Cant. 8 905000576</p>	<div style="text-align: center; font-weight: bold; font-size: 1.2em;">G</div>  <p>Screw 1/2"-13X1-1/2" <i>Vis 1/2"-13X1-1/2"</i> Tornillo 1/2"-13X1-1/2"</p> <p>Qty./QTÉ./Cant.: 2 905000575</p>	<div style="text-align: center; font-weight: bold; font-size: 1.2em;">H</div>  <p>Lock Washer 1/2" <i>Rondelle d'Enclenchement 1/2"</i> Arandela de Eganche 1/2"</p> <p>Qty./QTÉ./Cant.: 2 915000097</p>	<div style="text-align: center; font-weight: bold; font-size: 1.2em;">I</div>  <p>Screw 1/4"-20 X 1-1/2" <i>Vis 1/2-13 X 1-1/2"</i> Tornillo 1/2-13 X 1-1/2"</p> <p>Qty./QTÉ./Cant.: 1 905000223</p>

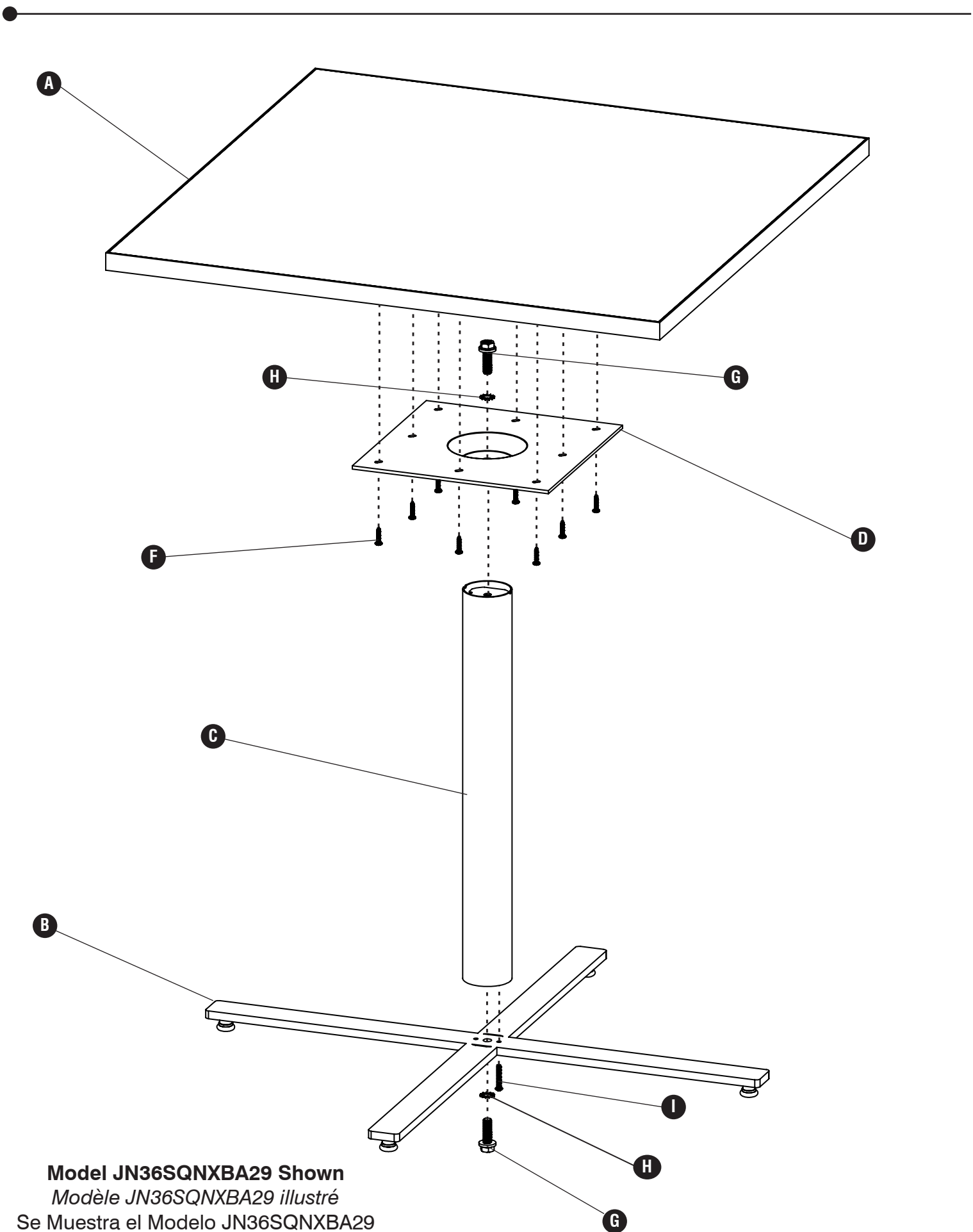

Model JN36SQNXBA29 Shown
Modèle JN36SQNXBA29 illustré
 Se Muestra el Modelo JN36SQNXBA29

- 1** **G**  (1) **H**  (1)

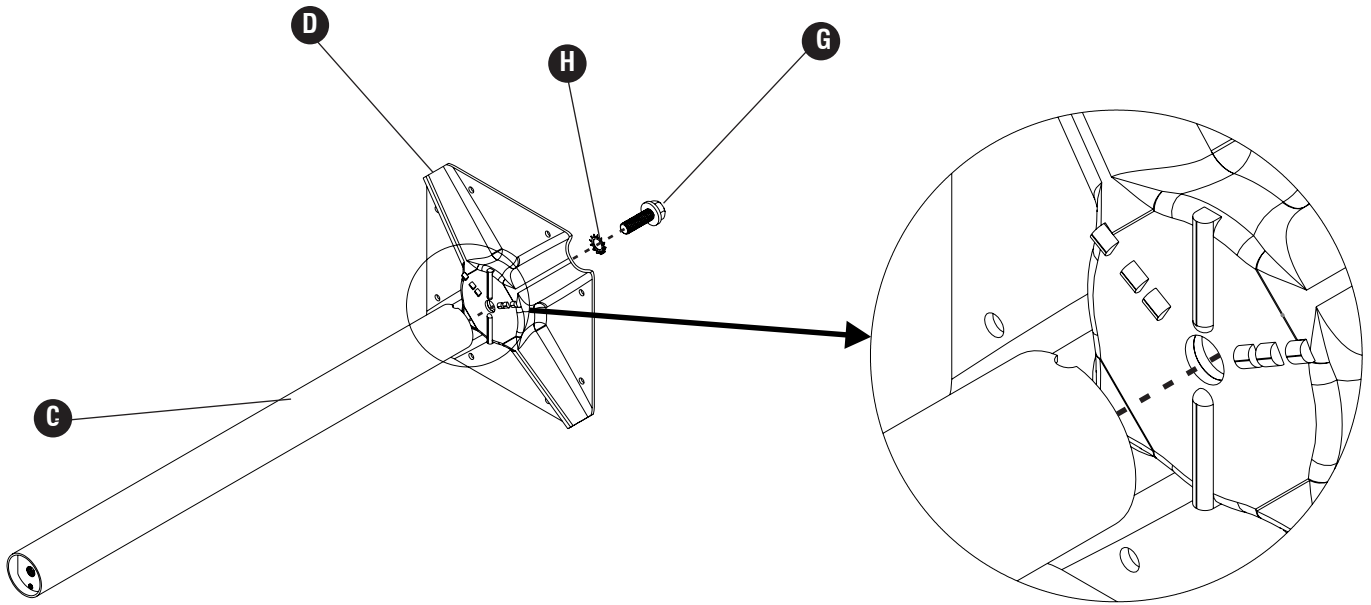

- 2** **G**  (1) **H**  (1) **I**  (1)

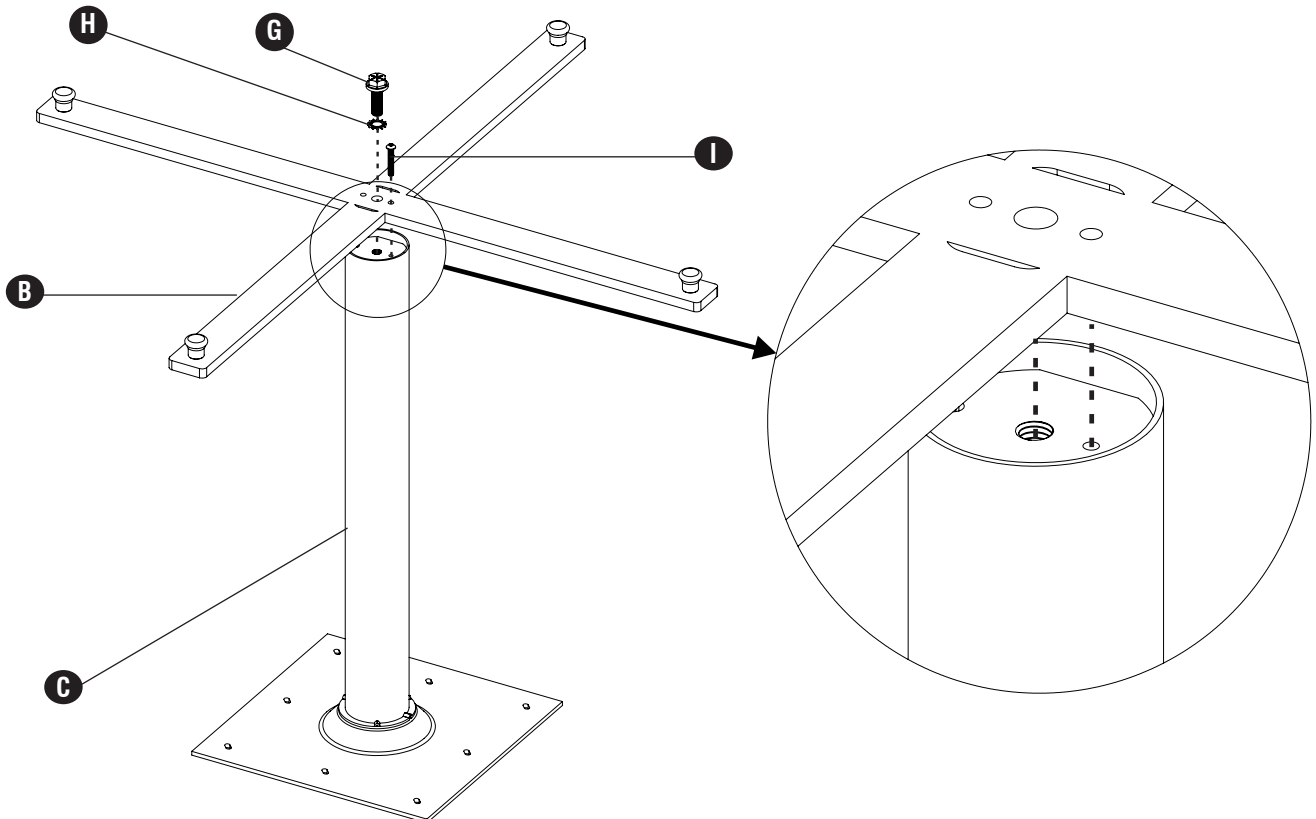

3

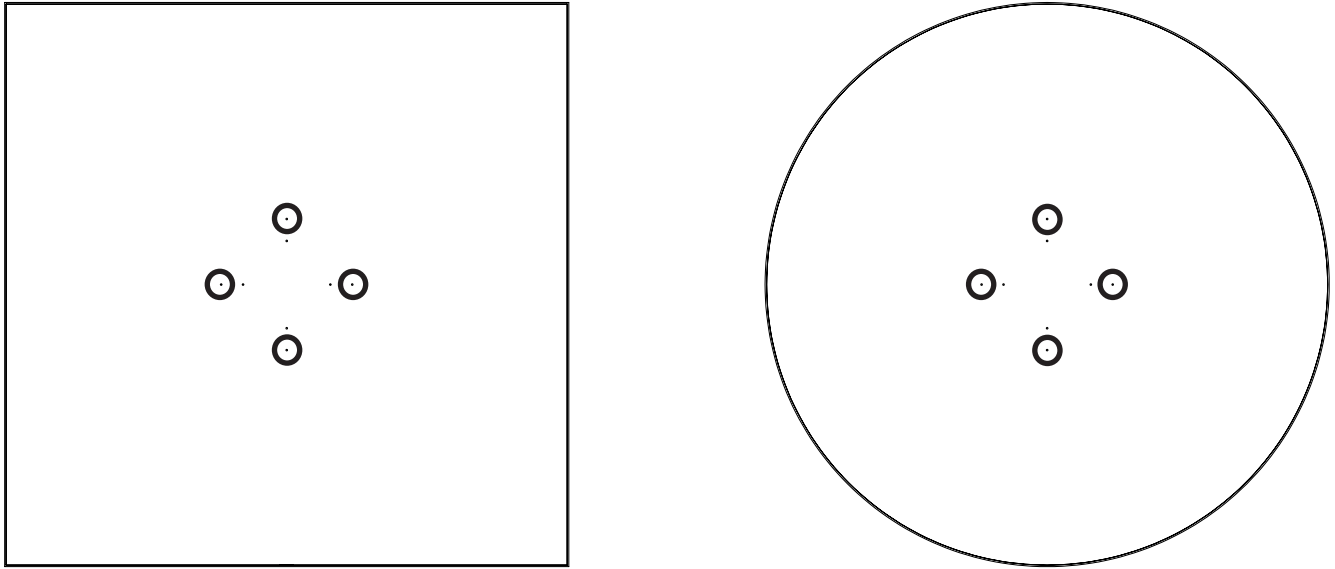

Circled holes will be used for the Mounting Plate.

Les trous encerclés seront utilisés pour la plaque de montage.

Se utilizarán orificios circulares para la placa de montaje.

4

F



(8)

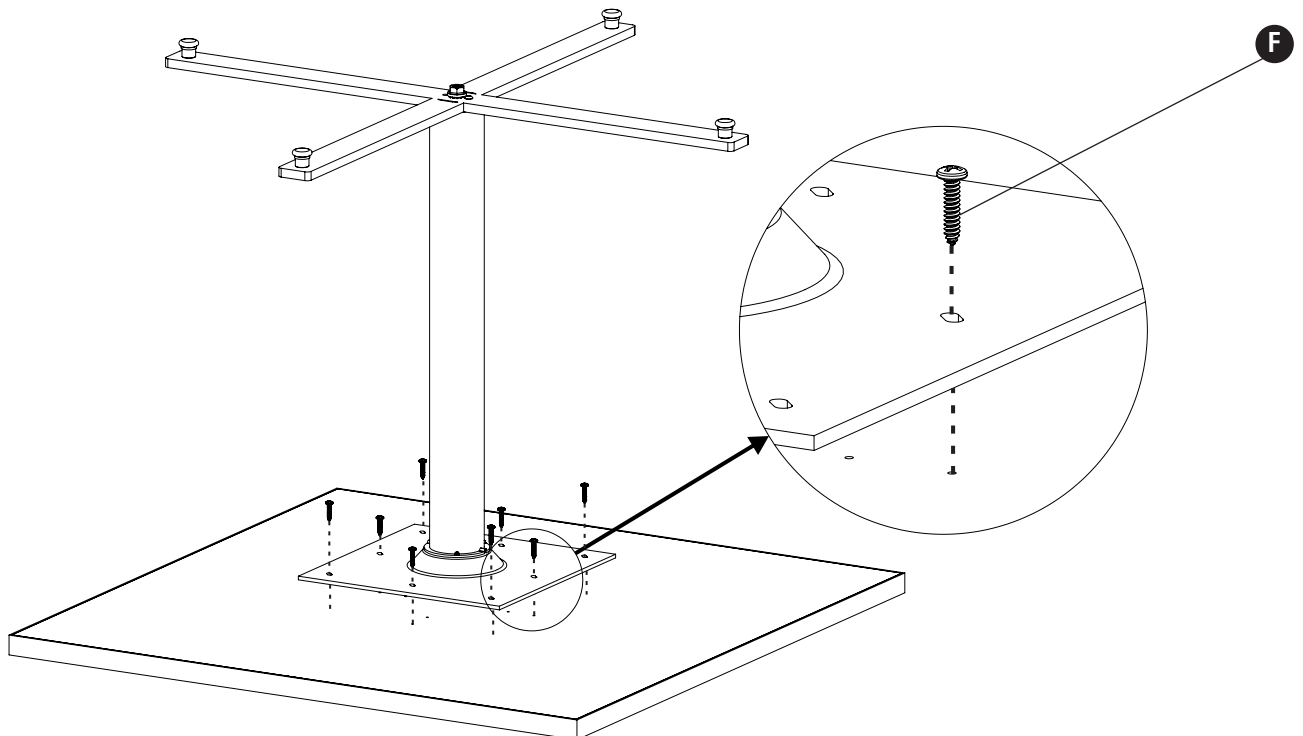

Install Mounting Plate to Top using screws. Use Pilot holes first.

Installez la plaque de montage sur le dessus à l'aide de vis. Utilisez d'abord les trous pilotes.

Instale la placa de montaje en la parte superior usando tornillos. Utilice agujeros piloto primero.

5

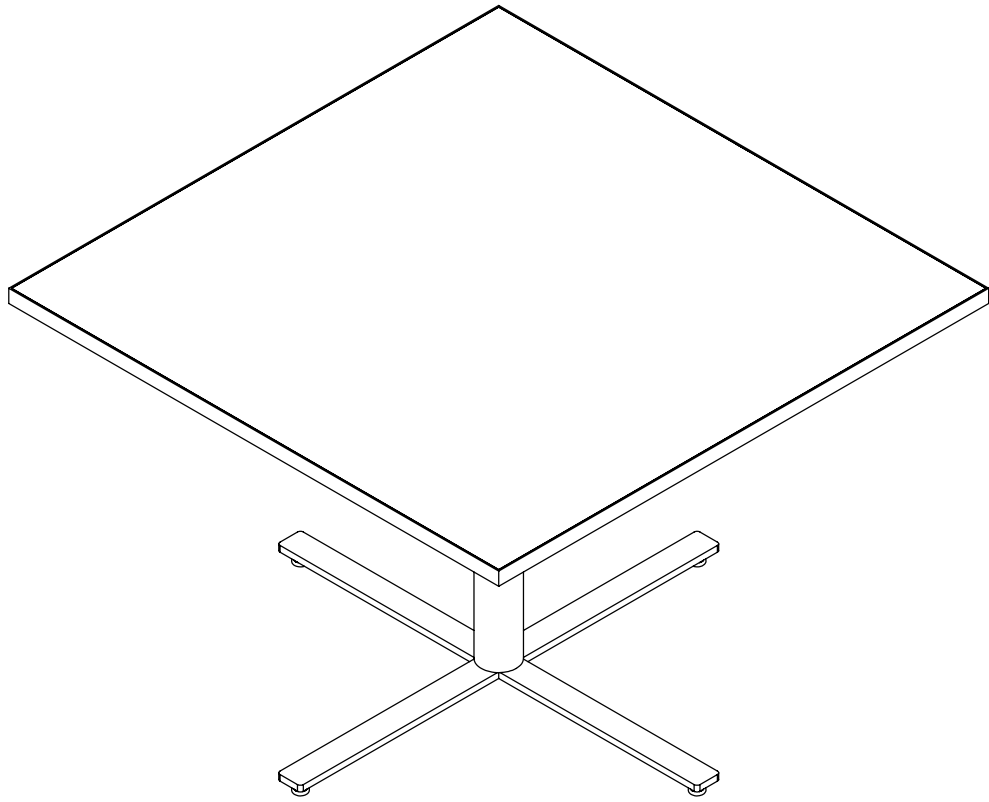

Flip the table over and adjust the levelers to level the table, if needed.
Retournez la table et ajustez les niveleurs pour niveler la table, si nécessaire.
Voltee la mesa y ajuste los niveladores para nivelar la mesa, si es necesario.