

JN*****FXP**

Jurni Post Leg Tables

Jurni Tables de Jambe de Poteau
Jurni Mesas con Patas de Poste

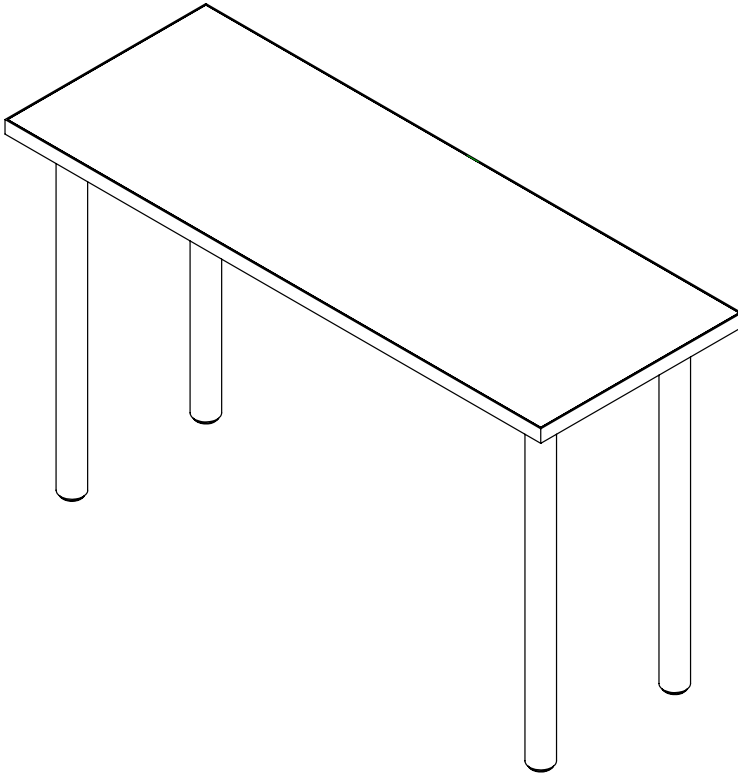

Model JN5418NFXPGL Shown
Modèle JN5418NFXPGL illustré
Se Muestra el Modelo JN5418NFXPGL

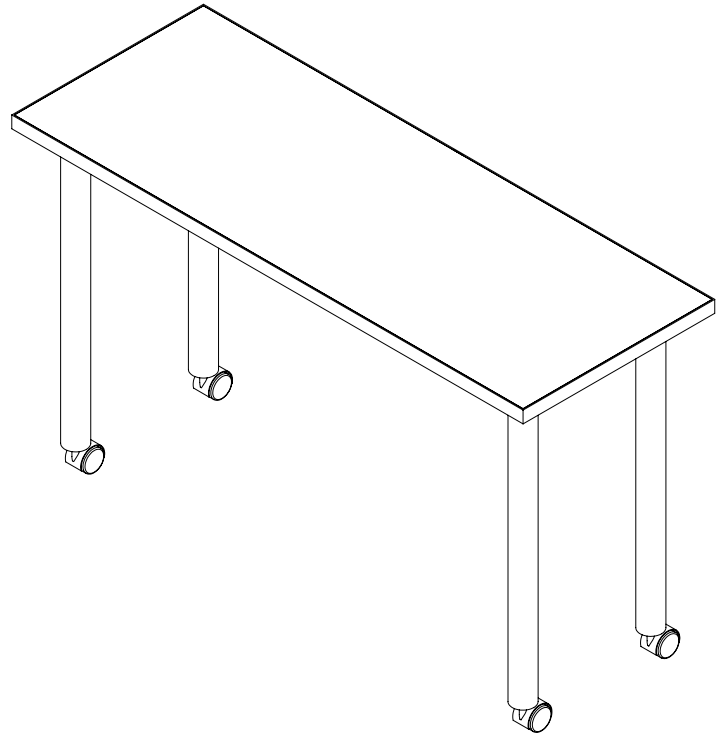

Model JN5418NFXPCA Shown
Modèle JN5418NFXPCA illustré
Se Muestra el Modelo JN5418NFXPCA

⚠ KEEP OUT OF REACH OF CHILDREN UNTIL ASSEMBLY IS COMPLETE, DUE TO THE PRESENCE OF SMALL OR SHARP PARTS.
ADULT ASSEMBLY REQUIRED

⚠ TENIR HORS DE PORTÉE DES ENFANTS JUSQU'À CE QUE
L'ASSEMBLAGE SOIT TERMINÉ, EN RAISON DE LA
PRÉSENCE DE PIÈCES PETITES OU TRANCHANTES.
ASSEMBLAGE ADULTE REQUIS

⚠ MANTENER FUERA DEL ALCANCE DE LOS NIÑOS HASTA QUE SE
COMPLETE EL MONTAJE, DEBIDO A LA
PRESENCIA DE PIEZAS PEQUEÑAS O AFILADAS.
SE REQUIERE MONTAJE DE ADULTOS

PRODUCT WARRANTY is available online at: www.safcoproducts.com

• LA GARANTIE DU PRODUIT est
disponible sur l'Internet : www.safcoproducts.com

• LA GARANTÍA DEL PRODUCTO está
disponible en la Internet: www.safcoproducts.com

For questions or concerns, please call **1-888-971-6225**
available Monday-Friday 7:30 AM to 5:00 PM (Central Time) (English-speaking operators)

Si vous avez des questions pour poser ou les préoccupations
pour exprimer, connecter au **1-888-971-6225**
de 7H30 à 17H00 (Heure centrale) (Opérateurs de langue anglaise)

Si usted tiene preguntas o preocupaciones,
por favor llame **1-888-971-6225**
de 7:30 AM a 5:00 PM (Hora Central) (Operadores que hablan inglés)

TOOLS REQUIRED: Drill with a Phillips Bit, Wrench, Mallet
OUTILS REQUIS : Percer avec un foret Phillips, Une Clé, Un Maillet
HERRAMIENTAS REQUERIDAS: Taladro con broca Phillips, Llave Inglesa, Mazo

PARTS LIST / LISTE DES PIÈCES / LISTA DE PIEZAS			
CODE / CODIGO	DESCRIPTION / DESCRIPTION / DESCRIPCIÓN	QTY. / QUANTITÉ/ CANTIDAD	PART NO. / N° DE PIECE / NO. DE PIEZA
(A)	Tabletop / Dessus de Table / Tablero		
	For JN4818NFXPGL / JN4818NFXPCA	1	640000470\$
	For JN4824NFXPGL / JN4824NFXPCA	1	640000471\$
	For JN4830NFXPGL / JN4830NFXPCA	1	640000472\$
	For JN5418NFXPGL / JN5418NFXPCA	1	640000473\$
	For JN5424NFXPGL / JN5424NFXPCA	1	640000474\$
	For JN5430NFXPGL / JN5430NFXPCA	1	640000475\$
	For JN6018NFXPGL / JN6018NFXPCA	1	640000476\$
	For JN6024NFXPGL / JN6024NFXPCA	1	640000477\$
	For JN6030NFXPGL / JN6030NFXPCA	1	640000478\$
	For JN6618NFXPGL / JN6618NFXPCA	1	640000479\$
	For JN6624NFXPGL / JN6624NFXPCA	1	640000480\$
	For JN6630NFXPGL / JN6630NFXPCA	1	640000481\$
	For JN7218NFXPGL / JN7218NFXPCA	1	640000482\$
	For JN7224NFXPGL / JN7224NFXPCA	1	640000483\$
	For JN7230NFXPGL / JN7230NFXPCA	1	640000484\$
	For JN4818EFXPGL / JN4818EFXPCA	1	640000485\$
	For JN4824EFXPGL / JN4824EFXPCA	1	640000488\$
	For JN4830EFXPGL / JN4830EFXPCA	1	640000491\$
	For JN5418EFXPGL / JN5418EFXPCA	1	640000494\$
	For JN5424EFXPGL / JN5424EFXPCA	1	640000497\$
	For JN5430EFXPGL / JN5430EFXPCA	1	640000503\$
	For JN6018EFXPGL / JN6018EFXPCA	1	640000506\$
	For JN6024EFXPGL / JN6024EFXPCA	1	640000509\$
	For JN6030EFXPGL / JN6030EFXPCA	1	640000512\$
	For JN6618EFXPGL / JN6618EFXPCA	1	640000515\$
	For JN6624EFXPGL / JN6624EFXPCA	1	640000518\$
	For JN6630EFXPGL / JN6630EFXPCA	1	640000521\$
	For JN7218EFXPGL / JN7218EFXPCA	1	640000524\$
	For JN7224EFXPGL / JN7224EFXPCA	1	640000527\$
	For JN7230EFXPGL / JN7230EFXPCA	1	640000530\$
	For JN4818GFXPGL / JN4818GFXPCA	1	640000486\$
	For JN4824GFXPGL / JN4824GFXPCA	1	640000489\$
	For JN4830GFXPGL / JN4830GFXPCA	1	640000492\$
	For JN5418GFXPGL / JN5418GFXPCA	1	640000495\$
	For JN5424GFXPGL / JN5424GFXPCA	1	640000498\$
	For JN5430GFXPGL / JN5430GFXPCA	1	640000504\$
	For JN6018GFXPGL / JN6018GFXPCA	1	640000507\$
	For JN6024GFXPGL / JN6024GFXPCA	1	640000510\$
	For JN6030GFXPGL / JN6030GFXPCA	1	640000513\$
	For JN6618GFXPGL / JN6618GFXPCA	1	640000516\$
	For JN6624GFXPGL / JN6624GFXPCA	1	640000519\$
	For JN6630GFXPGL / JN6630GFXPCA	1	640000522\$
	For JN7218GFXPGL / JN7218GFXPCA	1	640000525\$
	For JN7224GFXPGL / JN7224GFXPCA	1	640000528\$

PARTS LIST / LISTE DES PIÈCES / LISTA DE PIEZAS

CODE / CODIGO	DESCRIPTION / DESCRIPTION / DESCRIPCIÓN	QTY / QUANTITÉ / CANTIDAD	PART NO. / N° DE PIÈCE / NO. DE PIEZA
(A)	Tabletop / Dessus de Table / Tablerno		
	For JN7230GFXPGL / JN7230GFXPCA	1	640000531§
	For JN4818MFXPGL / JN4818MFXPCA	1	640000487§
	For JN4824MFXPGL / JN4824MFXPCA	1	640000490§
	For JN4830MFXPGL / JN4830MFXPCA	1	640000493§
	For JN5418MFXPGL / JN5418MFXPCA	1	640000496§
	For JN5424MFXPGL / JN5424MFXPCA	1	640000499§
	For JN5430MFXPGL / JN5430MFXPCA	1	640000505§
	For JN6018MFXPGL / JN6018MFXPCA	1	640000508§
	For JN6024MFXPGL / JN6024MFXPCA	1	640000511§
	For JN6030MFXPGL / JN6030MFXPCA	1	640000514§
	For JN6618MFXPGL / JN6618MFXPCA	1	640000517§
	For JN6624MFXPGL / JN6624MFXPCA	1	640000520§
	For JN6630MFXPGL / JN6630MFXPCA	1	640000523§
	For JN7218MFXPGL / JN7218MFXPCA	1	640000526§
	For JN7224MFXPGL / JN7224MFXPCA	1	640000529§
For JN7230MFXPGL / JN7230MFXPCA	1	640000532§	
(B)	Stiffener / Raidisseur / Rigidizador		
	For JN6018*FXP** / JN6024*FXP** / JN6030*FXP** / JN6618*FXP** / JN6624*FXP** / JN6630*FXP**	1	610000564
	For JN7218*FXP** / JN7224*FXP** / JN723*FXP**	1	610000565
(C)	Column Assembly / Assemblage de la colonne / Montaje de columna		
	For JN*****FXPGL	4	620000308§§
	For JN*****FXPCA	4	620000301§§
(D)	Leveler 5/16"-18 / Niveleur 5/16"-18 / Nivelador 5/16"-18		
	For JN*****FXPGL (Preinstalled)	4	960000092

§Note: When corresponding about parts, be sure to state top surface and edgebanding color.

§Noter: Quand correspondre au sujet de parties, soyez sûr d'affirmer surface supérieure et couleur de la bande de chant.

§Note: Al corresponder sobre las piezas, esté seguro declarar color de la superficie superior y de los cantos.

§§Note: When corresponding about parts, be sure to state paint color.

§§Noter: Lors de la correspondance sur les pièces, assurez-vous d'indiquer la couleur de la peinture.

§§Note: Cuando corresponda sobre las piezas, asegúrese de indicar el color de la pintura.

Hardware Pack / Paquet Matériel / Paquete Material:
900000455 (JN**FXPCA)**

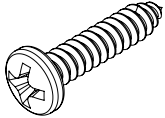
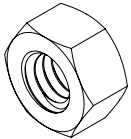
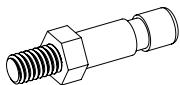
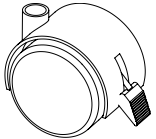
<p>E</p>  <p>Screw #12 X 1" <i>Vis #12 X 1"</i> Tornillo #12 X 1"</p> <p>Qty. / Qté. / Cant. 32 905000576</p>	<p>F</p>  <p>Nut 5/16"-18 <i>Écrou 5/16"-18</i> Tuerca 5/16"-18</p> <p>Qty. / Qté. / Cant. 4 910000057</p>	<p>G</p>  <p>Caster Stem 5/16"-18 <i>Tige de Roulette 5/16"-18</i> Vastago de Rueda 5/16"-18</p> <p>Qty. / Qté. / Cant. 4 970000093</p>	<p>H</p>  <p>Caster Wheel 2" <i>Roulette 2"</i> Rueda Giratoria 2"</p> <p>Qty. / Qté. / Cant. : 4 970000092</p>
--	---	---	--

Only for Post Leg Casters, Uniquement pour les roulettes Post Leg, Solo para ruedas con patas de poste,

Hardware Pack / Paquet Matériel / Paquete Material:
900000454 (JN**FXPGL)**

E



Screw #12 X 1"
Vis #12 X 1"
Tornillo #12 X 1"

Qty. / Qté. / Cant. 32
905000576

Only for Post Leg Glides
Uniquement pour les patins Post Leg
Solo para deslizadores posteriores a las piernas

Hardware Pack / Paquet Matériel / Paquete Material:
900000453 (Stiffener)

I

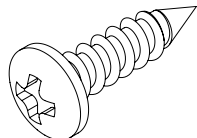

Screw #10 X 3/4"
Vis #10 X 3/4"
Tornillo #10 X 3/4"

Qty. / Qté. / Cant. 5
X11

Only for tables 60" or larger
Uniquement pour les tables de 60" ou plus
Solo para mesas de 60" o más grandes

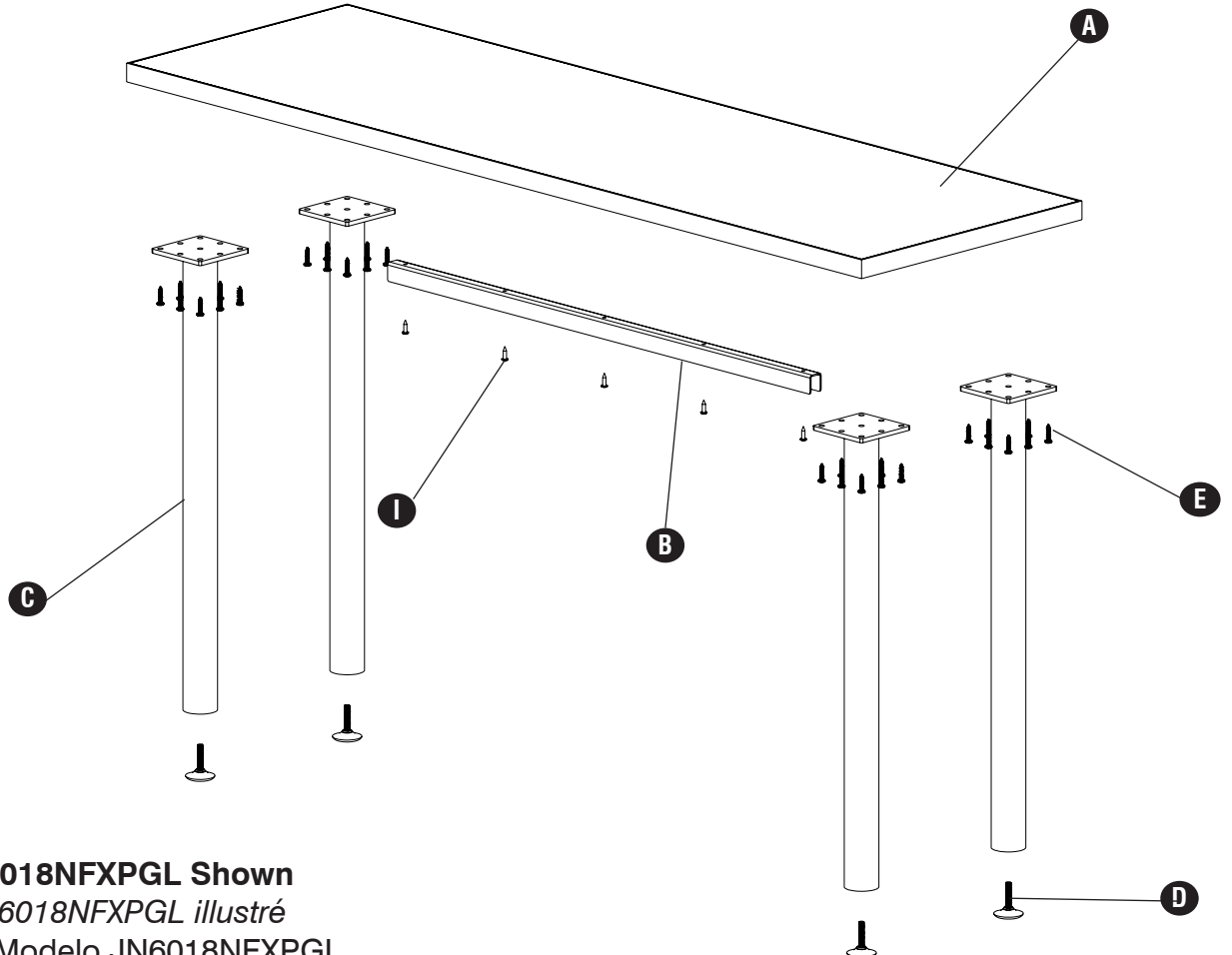

Model JN6018NFXPGL Shown
Modèle JN6018NFXPGL illustré
Se Muestra el Modelo JN6018NFXPGL

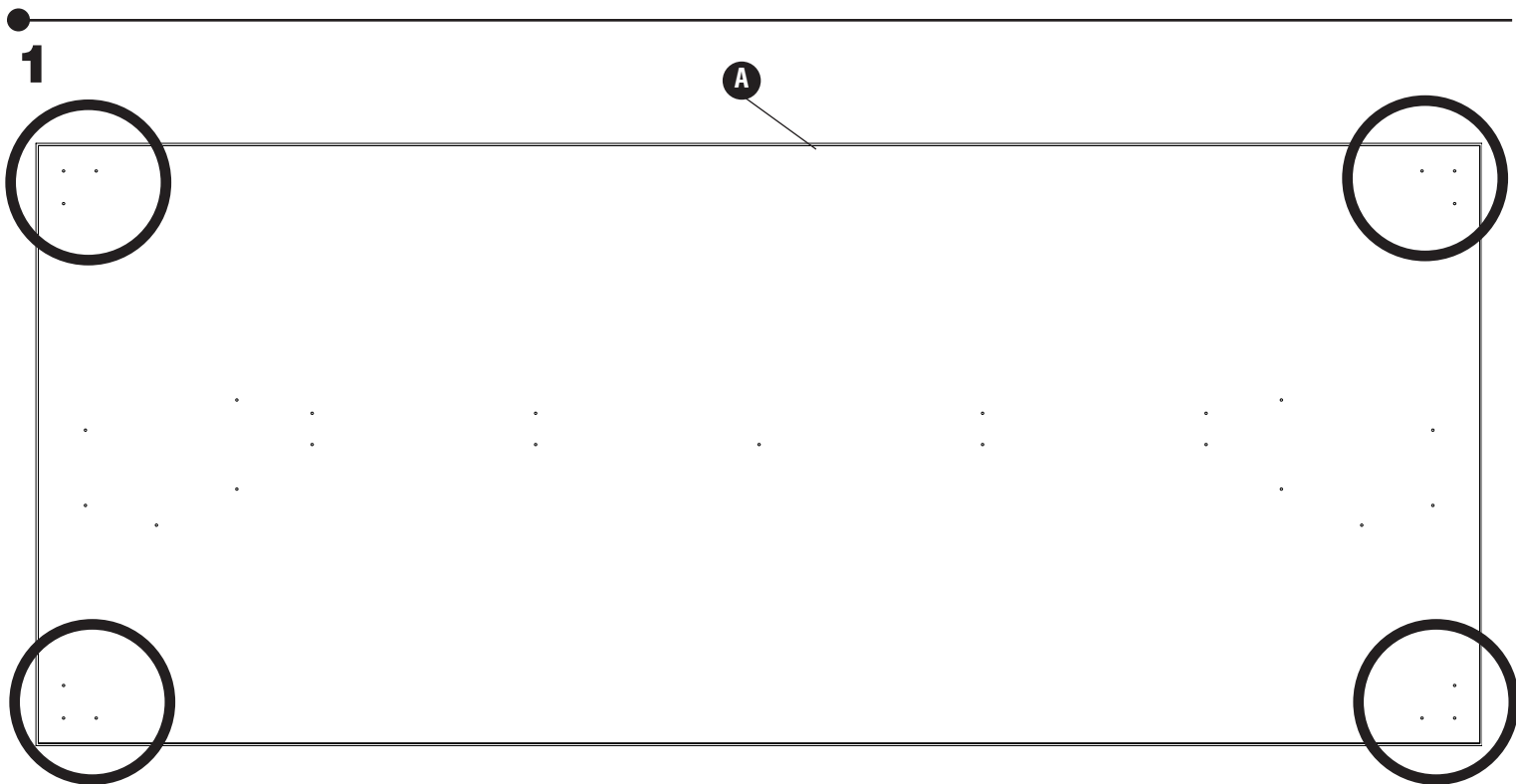

Circled holes will be used for the Post Legs.
Les trous encerclés seront utilisés pour les pieds de poteau.
Se utilizarán agujeros en círculos para las patas del poste.

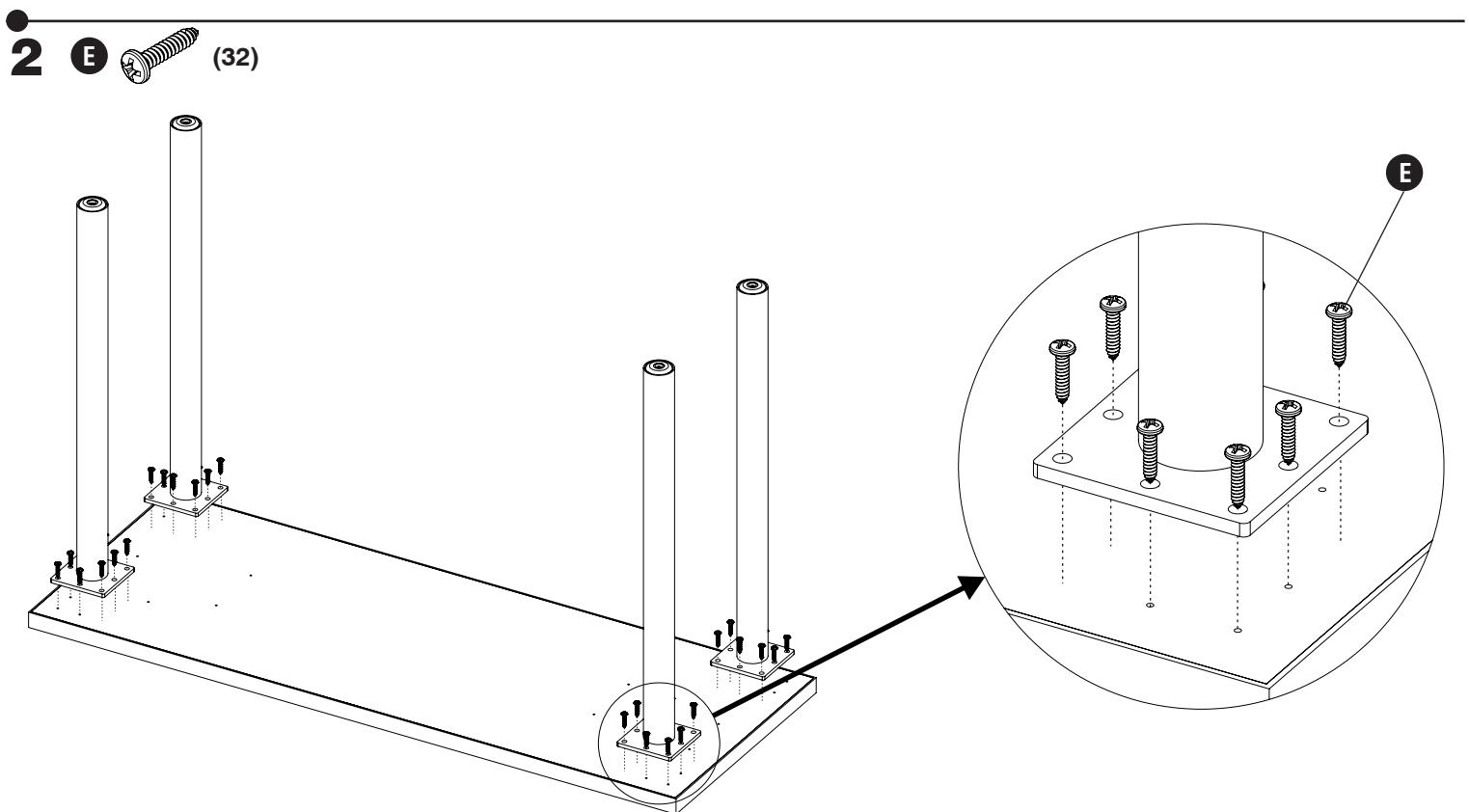

Install screws to secure legs to the top. Use Pilot holes first.
Installez les vis pour fixer les pieds au dessus. Utilisez d'abord les trous pilotes.
Instale tornillos para asegurar las patas a la parte superior. Utilice agujeros piloto primero.

3 **I** (5)

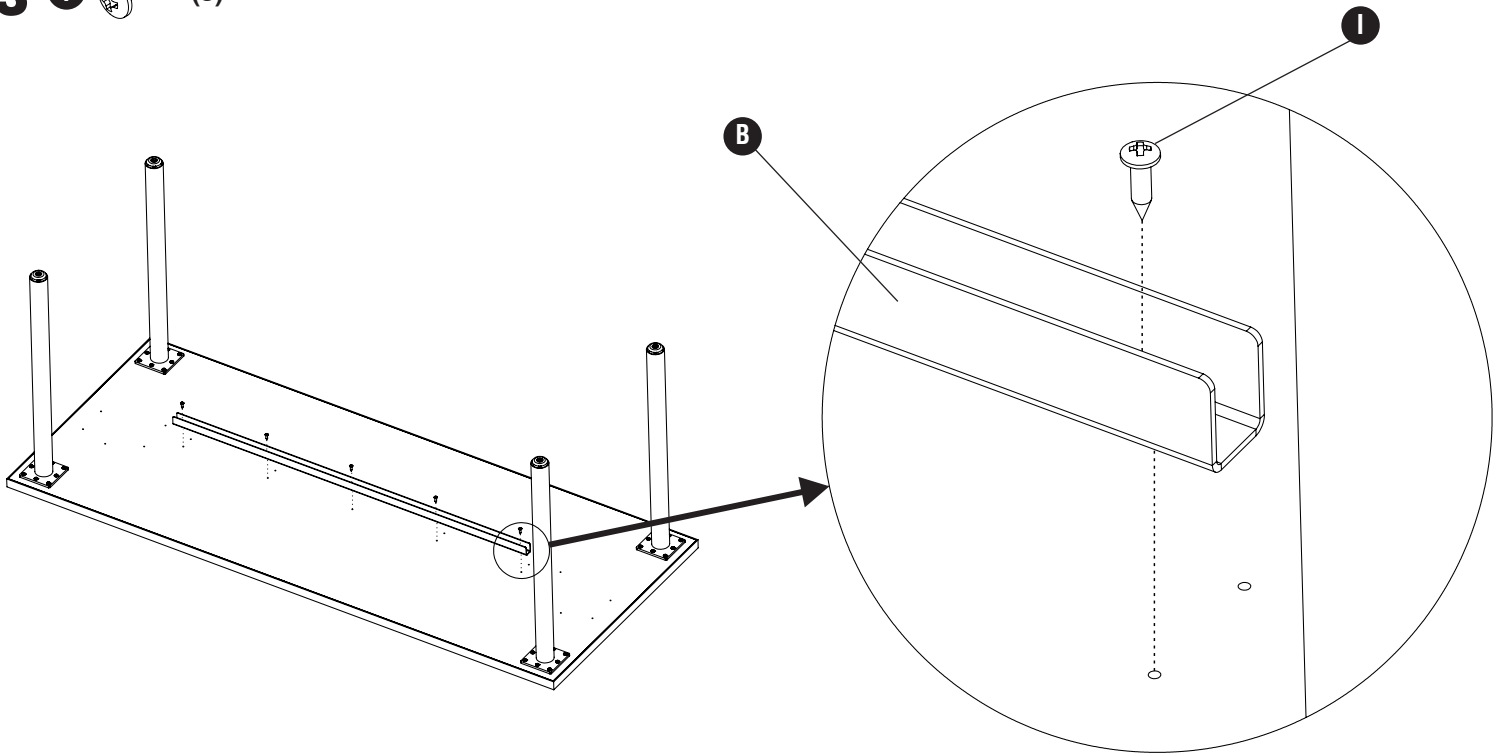

If a Stiffener is included, install using the 5 pilot holes in the center of the table.
Si un raidisseur est inclus, installez en utilisant les 5 trous pilotes au centre de la table.
Si se incluye un refuerzo, instale usando los 5 agujeros piloto en el centro de la tabla.

4 **F** (4) **G** (4)

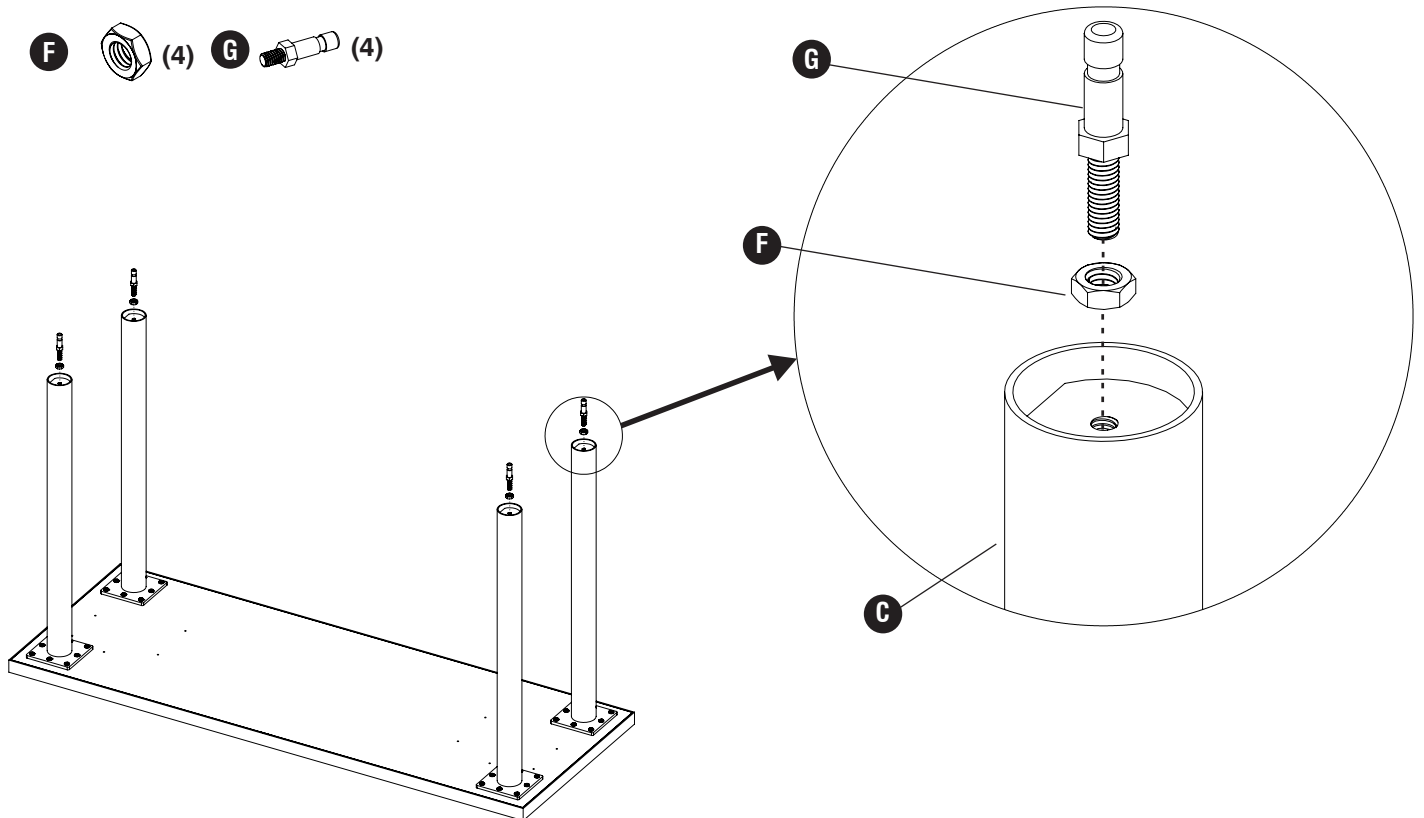

For legs with casters only.
Pour pieds à roulettes uniquement.
Solo para patas con ruedas.

5 H (4)

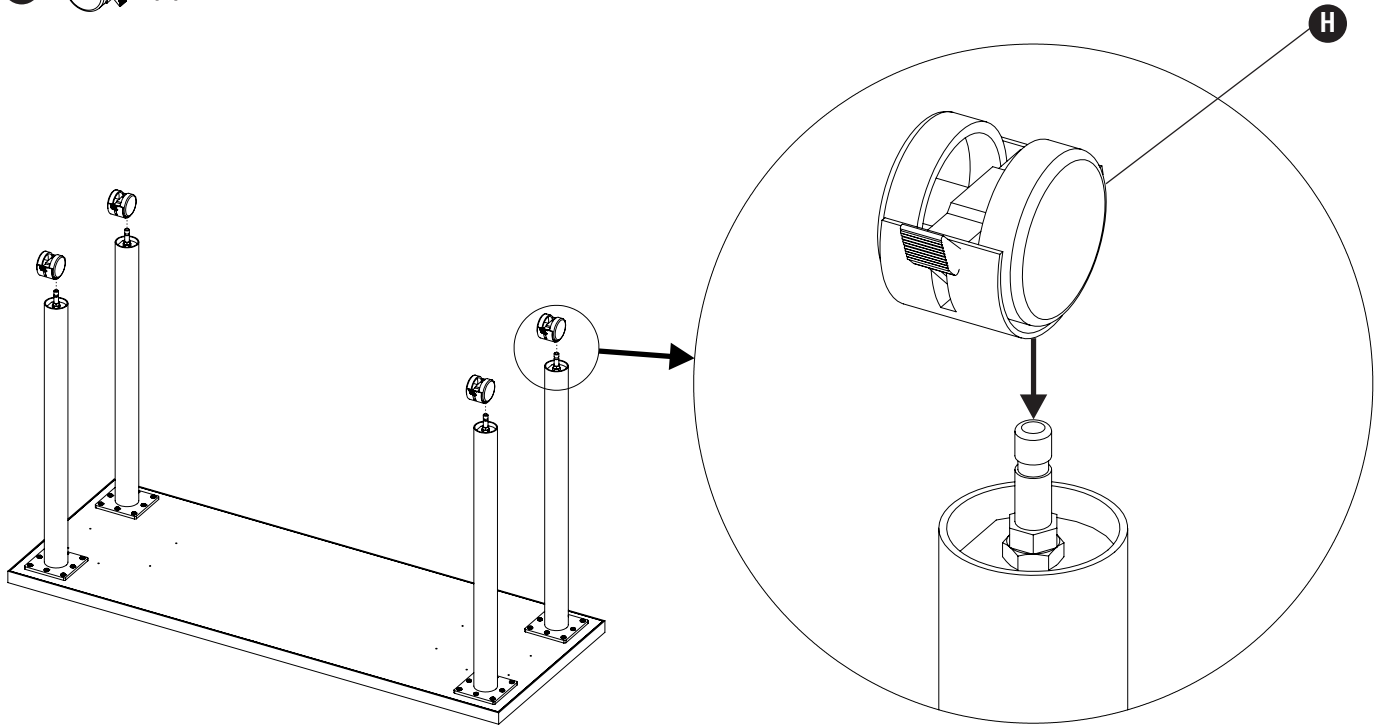

For Legs with Casters only. Install Casters on stem, use a mallet if needed.

Pour pieds avec roulettes uniquement. Installez les roulettes sur la tige, utilisez un maillet si nécessaire.

Solo para patas con ruedas. Instale las ruedas en el vástago, use un mazo si es necesario.

6

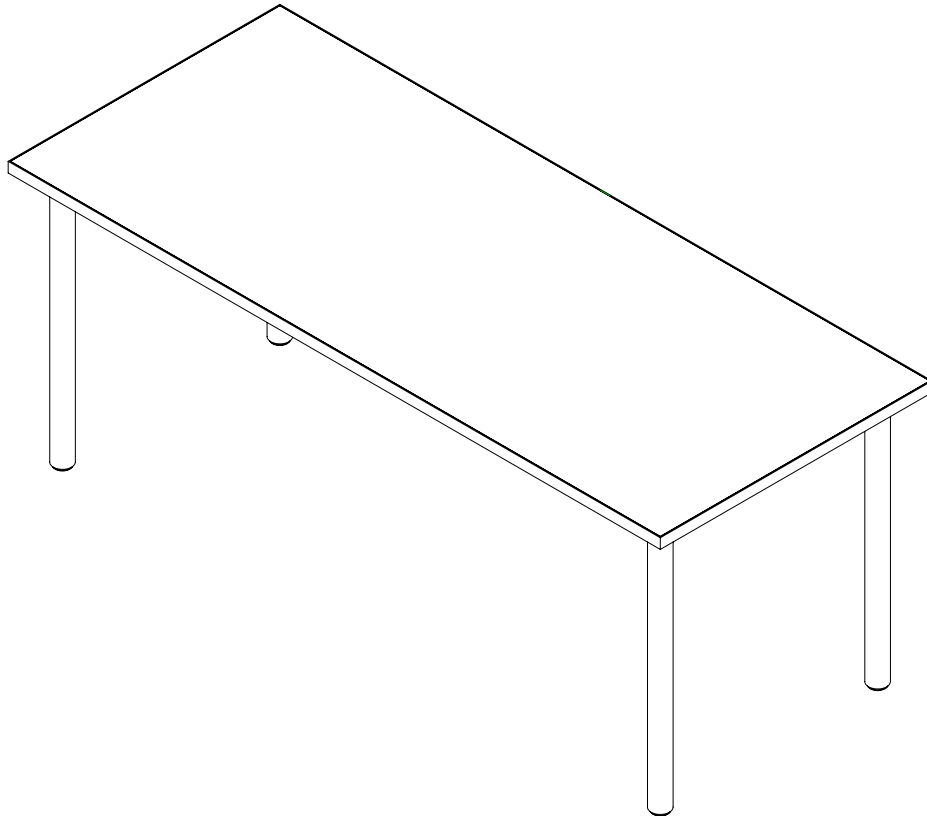

Flip the table over and adjust the levelers or casters to level the table. Periodically, re-tighten as needed.

Retournez la table et ajustez les niveleurs ou les roulettes pour niveler la table. Périodiquement, resserrez au besoin.

Voltee la mesa y ajuste los niveladores o ruedas para nivelar la mesa. Periódicamente, vuelva a apretar según sea necesario.