

JN***FXT****
Jurni T-Leg Tables
Jurni Tables à pieds en T
Jurni Mesas con patas en T

Model JN4830NFXTGL Shown
Modèle JN4830NFXTGL illustré
Se muestra el modelo JN4830NFXTGL

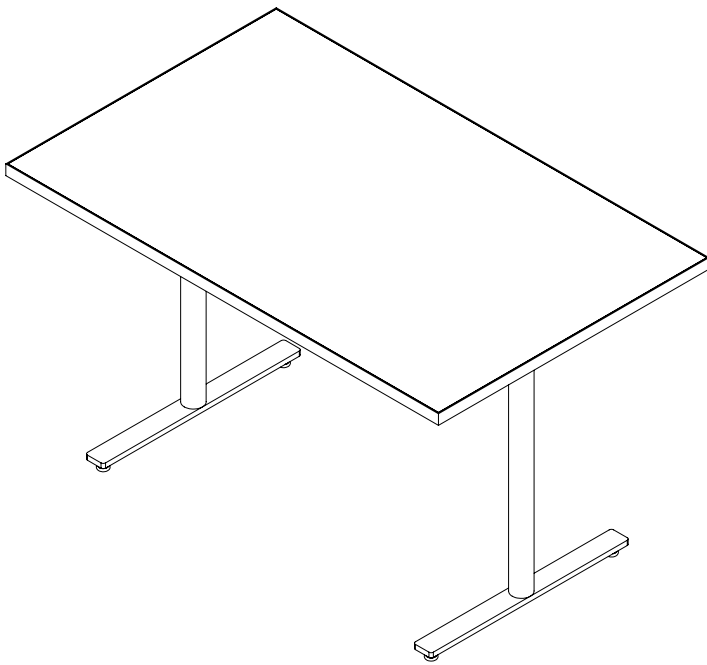
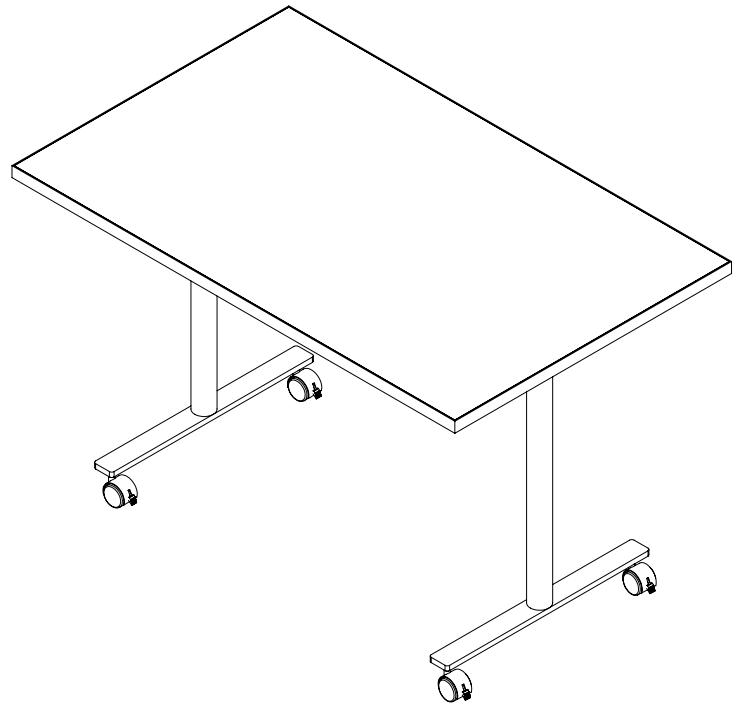

Model JN4830NFXTCA Shown
Modèle JN4830NFXTCA illustré
Se muestra el modelo JN4830NFXTCA

⚠ KEEP OUT OF REACH OF CHILDREN UNTIL ASSEMBLY IS COMPLETE, DUE TO THE PRESENCE OF SMALL OR SHARP PARTS.
ADULT ASSEMBLY REQUIRED

⚠ TENIR HORS DE PORTÉE DES ENFANTS JUSQU'À CE QUE
L'ASSEMBLAGE SOIT TERMINÉ, EN RAISON DE LA
PRÉSENCE DE PIÈCES PETITES OU TRANCHANTES.
ASSEMBLAGE ADULTE REQUIS

⚠ MANTENER FUERA DEL ALCANCE DE LOS NIÑOS HASTA QUE SE
COMPLETE EL MONTAJE, DEBIDO A LA
PRESENCIA DE PIEZAS PEQUEÑAS O AFILADAS.
SE REQUIERE MONTAJE DE ADULTOS

PRODUCT WARRANTY is available online at: **www.safcoproducts.com**

• LA GARANTIE DU PRODUIT est
disponible sur l'Internet : **www.safcoproducts.com**

• LA GARANTÍA DEL PRODUCTO está
disponible en la Internet: **www.safcoproducts.com**

For questions or concerns, please call **1-888-971-6225**
available Monday-Friday 7:30 AM to 5:00 PM (Central Time) (English-speaking operators)

Si vous avez des questions pour poser ou les préoccupations
pour exprimer, connecter au **1-888-971-6225**
de 7H30 à 17H00 (Heure centrale) (Opérateurs de langue anglaise)

Si usted tiene preguntas o preocupaciones,
por favor llame **1-888-971-6225**
de 7:30 AM a 5:00 PM (Hora Central) (Operadores que hablan inglés)

TOOLS REQUIRED: Drill with a Phillips Bit, Socket, Allen Wrench
OUTILS REQUIS : Percer avec un embout Phillips, une douille, une clé Allen
HERRAMIENTAS REQUERIDAS: Taladro con broca Phillips, dado, llave Allen

PARTS LIST / LISTE DES PIÈCES / LISTA DE PIEZAS			
CODE / CODIGO	DESCRIPTION / DESCRIPTION / DESCRIPCIÓN	QTY. / QUANTITÉ / CANTIDAD	PART NO. / N° DE PIÈCE / NO. DE PIEZA
(A)	Tabletop / Dessus de Table / Tablero		
	For JN4818NFXTGL / JN4818NFXTCA	1	640000470\$
	For JN4824NFXTGL / JN4824NFXTCA	1	640000471\$
	For JN4830NFXTGL / JN4830NFXTCA	1	640000472\$
	For JN5418NFXTGL / JN5418NFXTCA	1	640000473\$
	For JN5424NFXTGL / JN5424NFXTCA	1	640000474\$
	For JN5430NFXTGL / JN5430NFXTCA	1	640000475\$
	For JN6018NFXTGL / JN6018NFXTCA	1	640000476\$
	For JN6024NFXTGL / JN6024NFXTCA	1	640000477\$
	For JN6030NFXTGL / JN6030NFXTCA	1	640000478\$
	For JN6618NFXTGL / JN6618NFXTCA	1	640000479\$
	For JN6624NFXTGL / JN6624NFXTCA	1	640000480\$
	For JN6630NFXTGL / JN6630NFXTCA	1	640000481\$
	For JN7218NFXTGL / JN7218NFXTCA	1	640000482\$
	For JN7224NFXTGL / JN7224NFXTCA	1	640000483\$
	For JN7230NFXTGL / JN7230NFXTCA	1	640000484\$
	For JN4818EFXTGL / JN4818EFXTCA	1	640000485\$
	For JN4824EFXTGL / JN4824EFXTCA	1	640000488\$
	For JN4830EFXTGL / JN4830EFXTCA	1	640000491\$
	For JN5418EFXTGL / JN5418EFXTCA	1	640000494\$
	For JN5424EFXTGL / JN5424EFXTCA	1	640000497\$
	For JN5430EFXTGL / JN5430EFXTCA	1	640000503\$
	For JN6018EFXTGL / JN6018EFXTCA	1	640000506\$
	For JN6024EFXTGL / JN6024EFXTCA	1	640000509\$
	For JN6030EFXTGL / JN6030EFXTCA	1	640000512\$
	For JN6618EFXTGL / JN6618EFXTCA	1	640000515\$
	For JN6624EFXTGL / JN6624EFXTCA	1	640000518\$
	For JN6630EFXTGL / JN6630EFXTCA	1	640000521\$
	For JN7218EFXTGL / JN7218EFXTCA	1	640000524\$
	For JN7224EFXTGL / JN7224EFXTCA	1	640000527\$
	For JN7230EFXTGL / JN7230EFXTCA	1	640000530\$
	For JN4818GFXTGL / JN4818GFXTCA	1	640000486\$
	For JN4824GFXTGL / JN4824GFXTCA	1	640000489\$
	For JN4830GFXTGL / JN4830GFXTCA	1	640000492\$
	For JN5418GFXTGL / JN5418GFXTCA	1	640000495\$
	For JN5424GFXTGL / JN5424GFXTCA	1	640000498\$
	For JN5430GFXTGL / JN5430GFXTCA	1	640000504\$
	For JN6018GFXTGL / JN6018GFXTCA	1	640000507\$
	For JN6024GFXTGL / JN6024GFXTCA	1	640000510\$
	For JN6030GFXTGL / JN6030GFXTCA	1	640000513\$
	For JN6618GFXTGL / JN6618GFXTCA	1	640000516\$
	For JN6624GFXTGL / JN6624GFXTCA	1	640000519\$
	For JN6630GFXTGL / JN6630GFXTCA	1	640000522\$
	For JN7218GFXTGL / JN7218GFXTCA	1	640000525\$
	For JN7224GFXTGL / JN7224GFXTCA	1	640000528\$
	For JN7230GFXTGL / JN7230GFXTCA	1	640000531\$
	For JN4818MFXTGL / JN4818MFXTCA	1	640000487\$
	For JN4824MFXTGL / JN2418MFXTCA	1	640000490\$

§Note: When corresponding about parts, be sure to state top surface and edgbanding color.

§Note: Quand correspondre au sujet de parties, soyez sûr d'affirmer surface supérieure et couleur de la bande de chant.

§Note: Al corresponder sobre las piezas, esté seguro declarar color de la superficie superior y de los cantos.

PARTS LIST / LISTE DES PIÈCES / LISTA DE PIEZAS

CODE / CODIGO	DESCRIPTION / DESCRIPTION / DESCRIPCIÓN	QTY. / QUANTITÉ / CANTIDAD	PART NO. / N° DE PIÈCE / NO. DE PIEZA
Ⓐ	Tabletop / Dessus de Table / Tablero		
	For JN4830MFXTGL / JN4830MFXTCA	1	640000493\$
	For JN5418MFXTGL / JN5418MFXTCA	1	640000496\$
	For JN5424MFXTGL / JN5424MFXTCA	1	640000499\$
	For JN5430MFXTGL / JN5430MFXTCA	1	640000505\$
	For JN6018MFXTGL / JN6018MFXTCA	1	640000508\$
	For JN6024MFXTGL / JN6024MFXTCA	1	640000511\$
	For JN6030MFXTGL / JN6030MFXTCA	1	640000514\$
	For JN6618MFXTGL / JN6618MFXTCA	1	640000517\$
	For JN6624MFXTGL / JN6624MFXTCA	1	640000520\$
	For JN6630MFXTGL / JN6630MFXTCA	1	640000523\$
	For JN7218MFXTGL / JN7218MFXTCA	1	640000526\$
	For JN7224MFXTGL / JN7224MFXTCA	1	640000529\$
	For JN7230MFXTGL / JN7230MFXTCA	1	640000532\$
Ⓑ	Stiffener / Raidisseur / Rigidizador		
	For JN6018*FXT** / JN6024*FXT** / JN6030*FXT** / JN6618*FXT** / JN6624*FXT** / JN6630*FXT**	1	610000564
	For JN7218*FXT** / JN7224*FXT** / JN723*FXT**	1	610000565
Ⓒ	Mounting Plate / Plaque de montage / Placa de montaje	2	620000285
Ⓓ	Column Assembly / Assemblage de la colonne / Montaje de columna		
	For JN*****FXPGL	4	620000300\$\$
	For JN*****FXPCA	4	620000301\$\$
Ⓔ	Mainbar / Barre Principale / Barra Principal		
	For JN*****FXTGL	2	620000307
	For JN*****FXTCA	2	620000282
Ⓕ	Leveler 5/16"-18 / Niveleur 5/16"-18 / Nivelador 5/16"-18		
	For JN*****FXTGL (Preinstalled)	4	960000092

§Note: When corresponding about parts, be sure to state top surface and edgebanding color.

§Noter: Quand correspondre au sujet de parties, soyez sûr d'affirmer surface supérieure et couleur de la bande de chant.



§Note: Al corresponder sobre las piezas, esté seguro declarar color de la superficie superior y de los cantos.

§§Note: When corresponding about parts, be sure to state paint color.



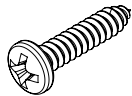
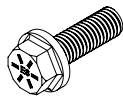

§§Noter: Lors de la correspondance sur les pièces, assurez-vous d'indiquer la couleur de la peinture.

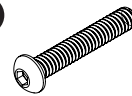
§§Note: Cuando corresponda sobre las piezas, asegúrese de indicar el color de la pintura.

TOOLS REQUIRED: Drill with a Phillips Bit, Socket, Allen Wrench
OUTILS REQUIS : Percer avec un embout Phillips, une douille, une clé Allen
HERRAMIENTAS REQUERIDAS: Taladro con broca Phillips, dado, llave Allen

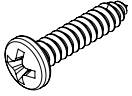
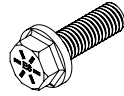
HARDWARE PACK / PAQUET MATÉRIAL / PAQUETE MATERIAL 900000456 (JN****FXTGL)			
G 	H 	I 	J 
Screw #12 X 1" Vis #12 X 1" Tornillo #12 X 1" Qty./QTÉ./Cant.: 16 905000576	Screw 1/2"-13X1-1/2" Vis 1/2"-13X1-1/2" Tornillo 1/2"-13X1-1/2" Qty./QTÉ./Cant.: 4 905000575	Lock Washer 1/2" Rondelle d'Enclenchement 1/2" Arandela de Eganche 1/2" Qty./QTÉ./Cant.: 4 915000097	Screw 1/4"-20 X 1-1/2" Vis 1/4"-20 X 1-1/2" Tornillo 1/4"-20 X 1-1/2" Qty./QTÉ./Cant.: 2

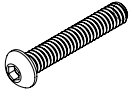
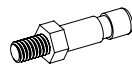
Only for Post Leg Glides
Uniquement pour les patins Post Leg
 Solo para deslizadores posteriores a las piernas

HARDWARE PACK / PAQUET MATÉRIAL / PAQUETE MATERIAL 900000457 (JN****FXTCA)		
G 	H 	I 
Screw #12 X 1" Vis #12 X 1" Tornillo #12 X 1" Qty./QTÉ./Cant.: 16 905000576	Screw 1/2"-13X1-1/2" Vis 1/2"-13X1-1/2" Tornillo 1/2"-13X1-1/2" Qty./QTÉ./Cant.: 4 905000575	Lock Washer 1/2" Rondelle d'Enclenchement 1/2" Arandela de Eganche 1/2" Qty./QTÉ./Cant.: 4 915000097
J 	K 	L 
Screw 1/4"-20 X 1-1/2" Vis 1/4"-20 X 1-1/2" Tornillo 1/4"-20 X 1-1/2" Qty./QTÉ./Cant.: 2	Caster Stem 5/16"-18 Tige de Roulette 5/16"-18 Vástago de Rueda 5/16"-18 Qty./QTÉ./Cant.: 4 970000093	Caster Wheel 2" Roulette 2" Rueda Giratoria 2" Qty./QTÉ./Cant.: 4 970000092

Only for Post Leg Casters, Uniquement pour les roulettes Post Leg,
 Solo para ruedas con patas de poste

HARDWARE PACK PAQUET MATÉRIAL PAQUETE MATERIAL 900000453 (Stiffener)
M 
Screw #10 X 3/4" Vis #10 X 3/4" Tornillo #10 X 3/4" Qty. / Qté. / Cant. 5 X11

Only for tables 60" or larger
Uniquement pour les tables de 60" ou plus
 Solo para mesas de 60" o más grandes

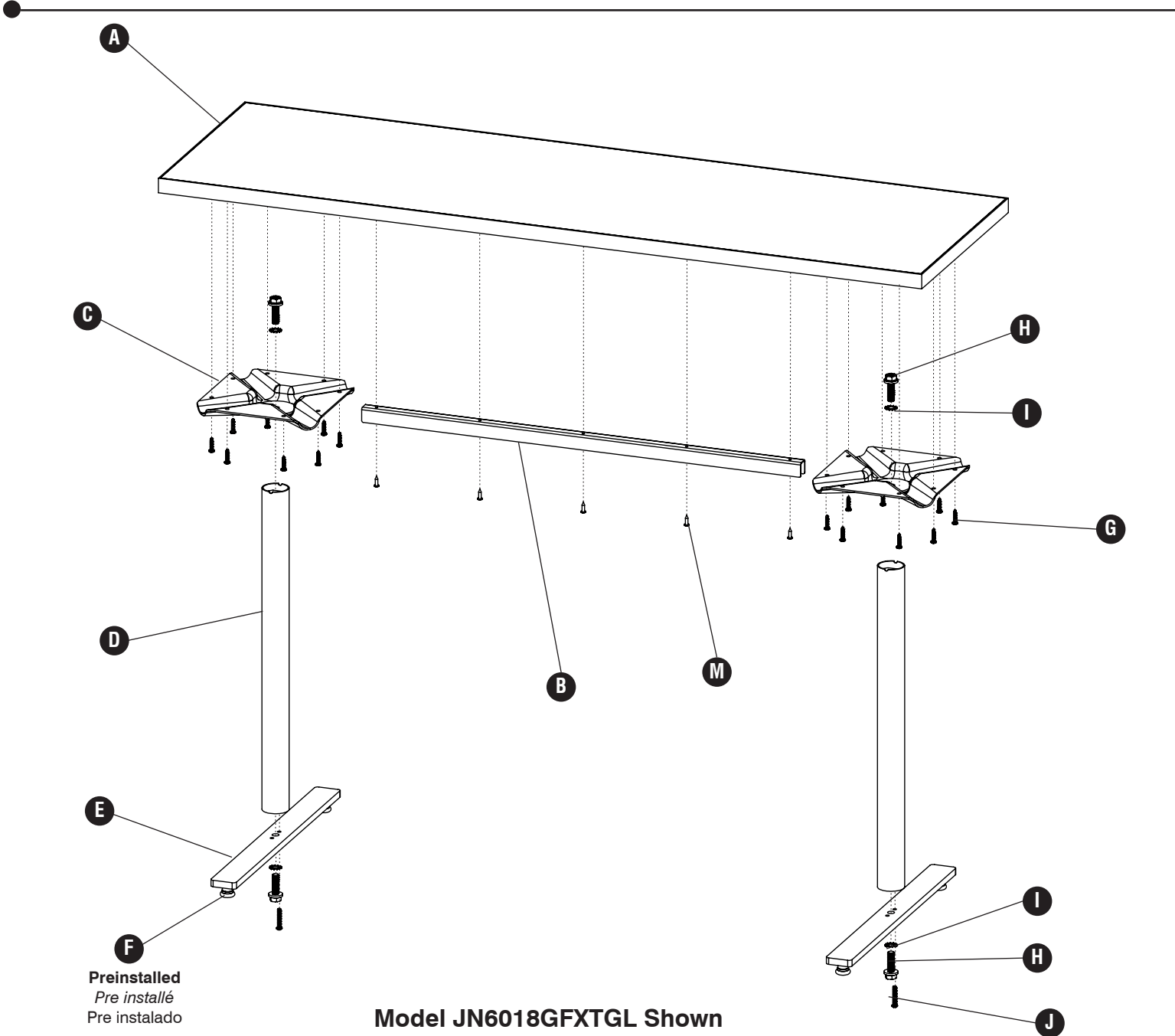

Preinstalled
 Pre installé
 Pre instalado

Model JN6018GFXTGL Shown
Modèle JN6018GFXTGL illustré
 Se Muestra el Modelo JN6018GFXTGL

1 H (2) I (2)

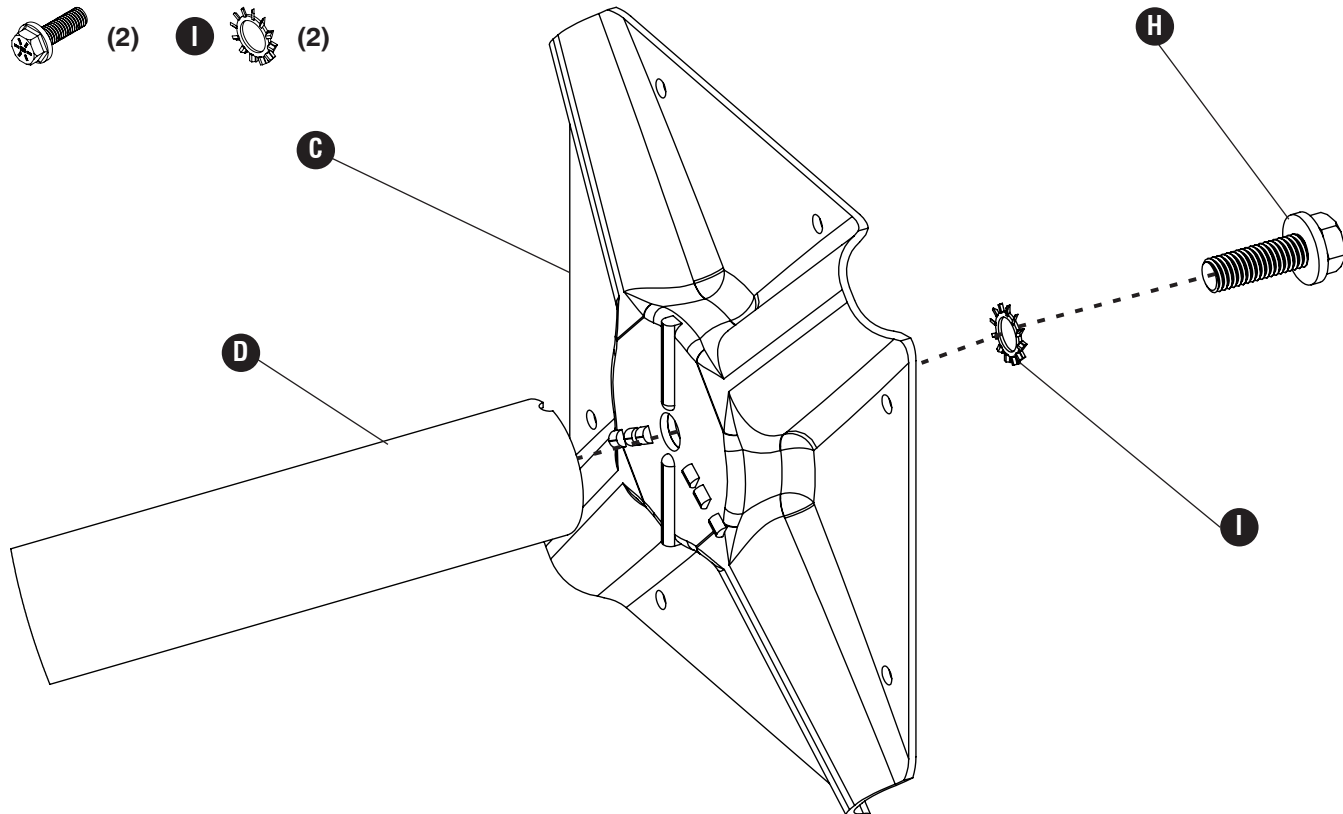

Make sure groove in Column matches the bottom of the Mounting Plate.

Assurez-vous que la rainure de la colonne correspond au bas de la plaque de montage.

Asegúrese de que la ranura de la columna coincida con la parte inferior de la placa de montaje.

2 H (2) I (2) J (2)

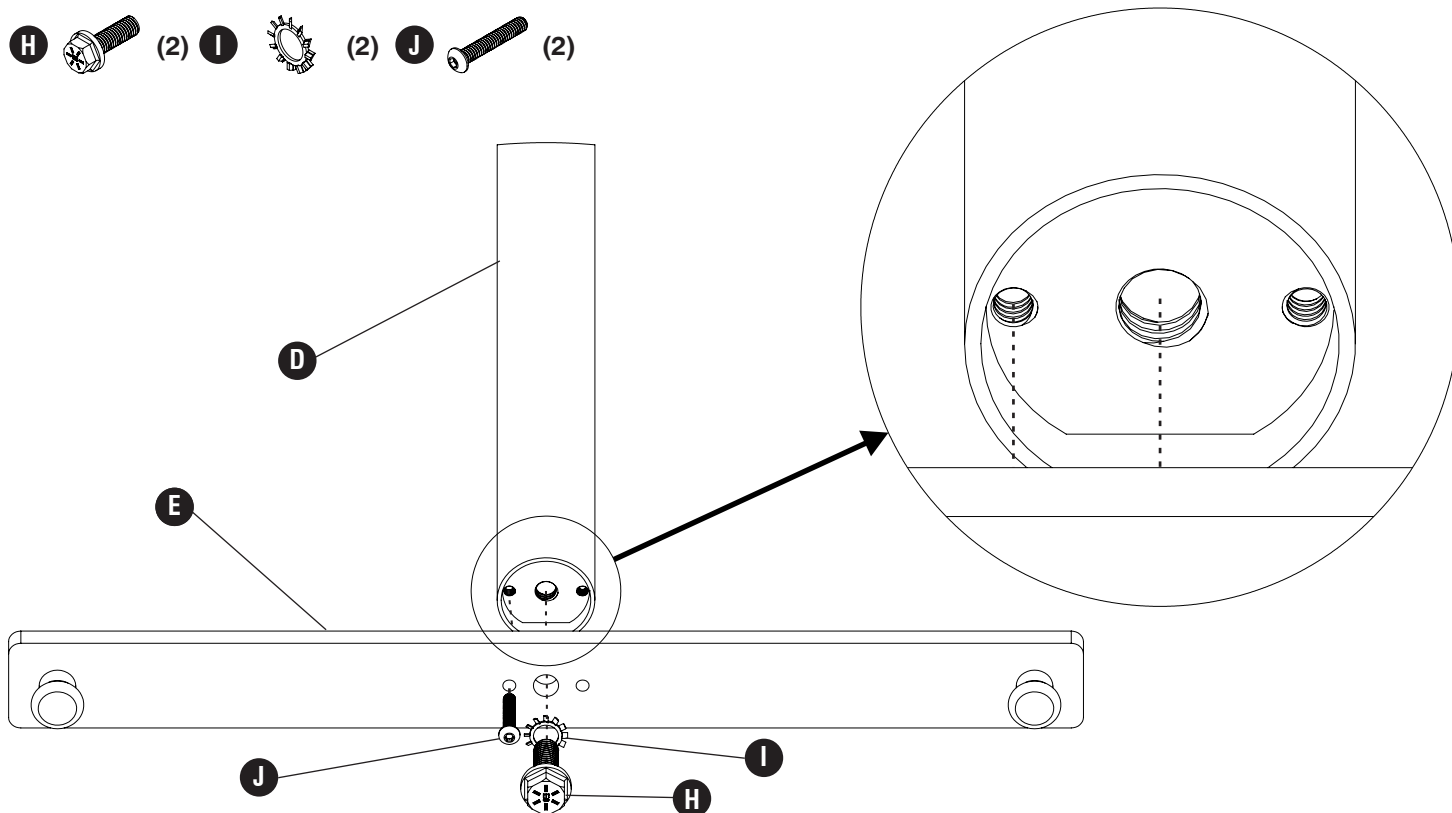

3 **K**  (4)

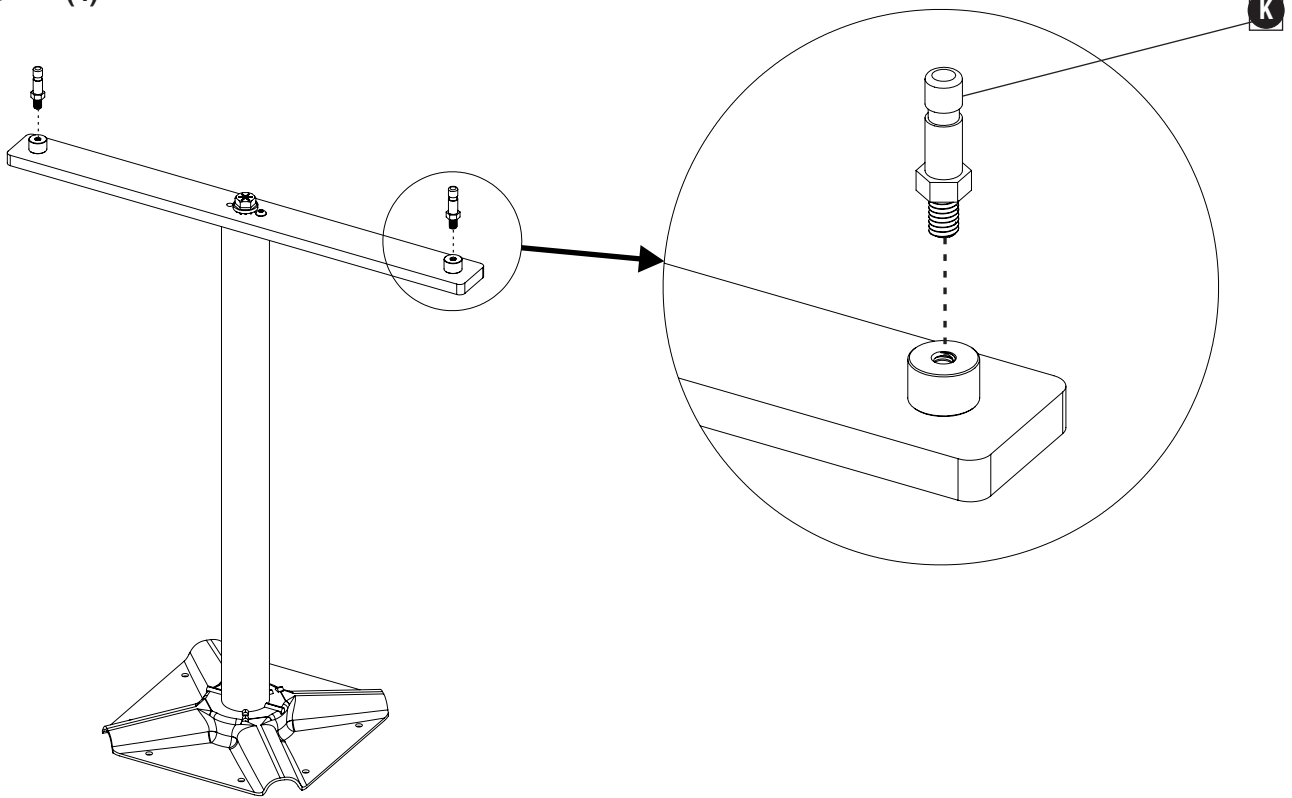

For legs with casters only.
Pour pieds à roulettes uniquement.
Solo para patas con ruedas.

4 **L**  (4)

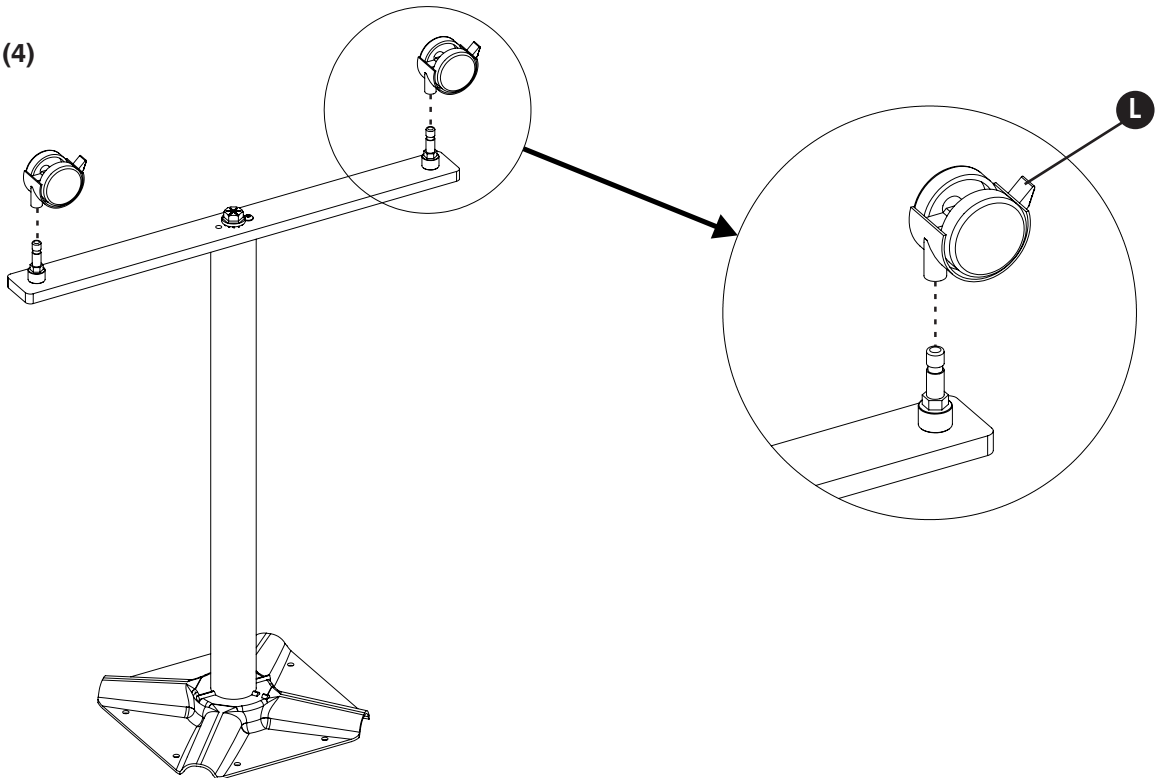

For Legs with Casters only. Install Casters on stem, use a mallet if needed.
Pour pieds avec roulettes uniquement. Installez les roulettes sur la tige, utilisez un maillet si nécessaire.
Solo para patas con ruedas. Instale las ruedas en el vástago, use un mazo si es necesario.

5

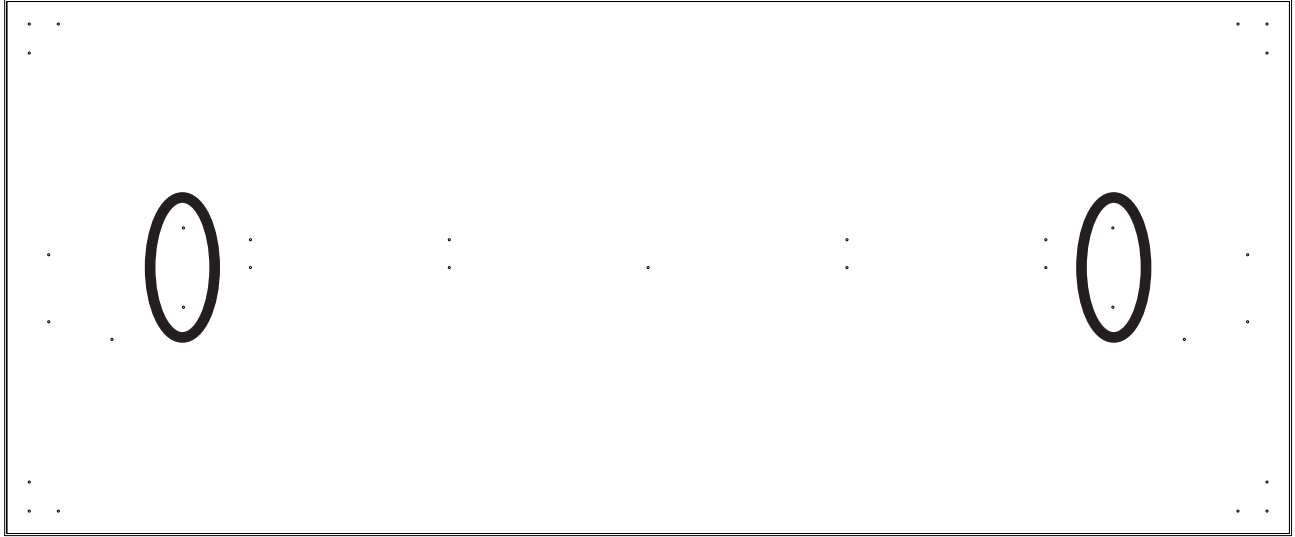

Circled holes will be used for the Mounting Plate attachment.

Les trous encerclés seront utilisés pour la fixation de la plaque de montage.

Circled holes will be used for the Mounting Plate attachment.

6 G (16)

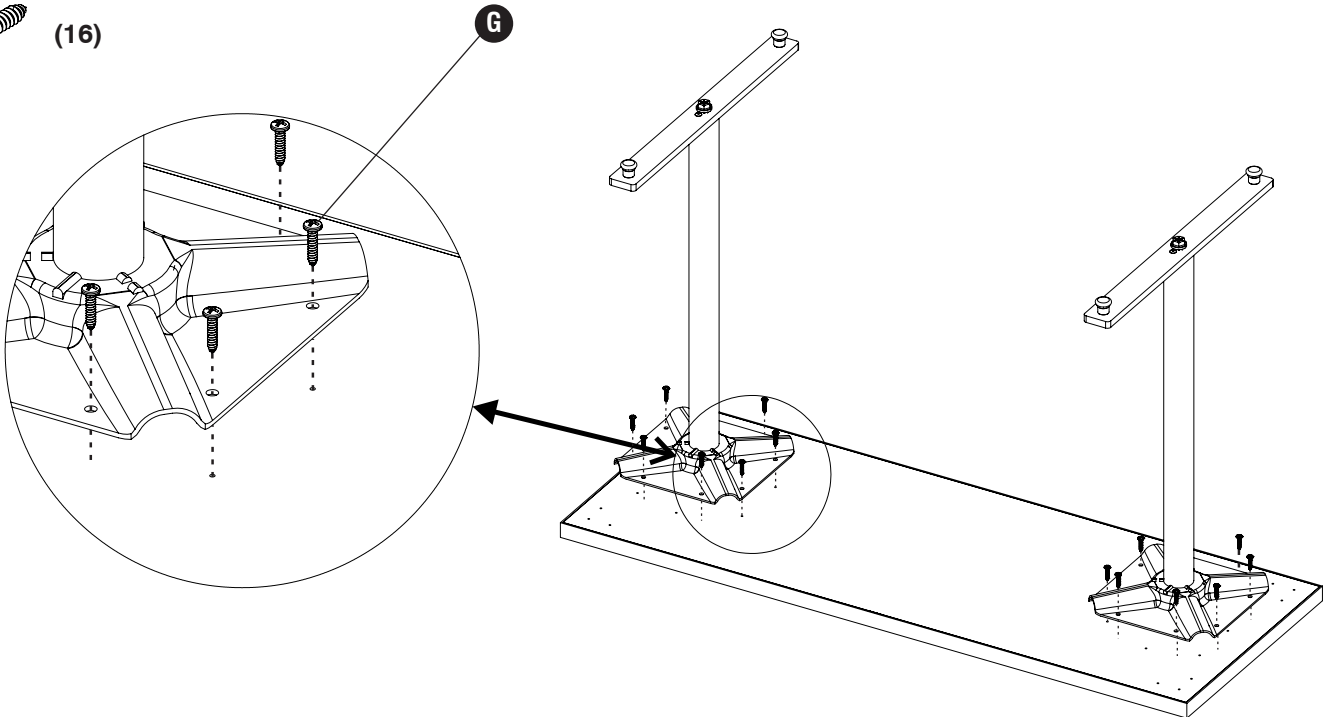

Attach the Mounting Plates to the Top using the pilot holes first.

Fixez les plaques de montage au dessus en utilisant d'abord les avant-trous.

Fije las placas de montaje a la parte superior utilizando primero los orificios guía.

7 M (5)

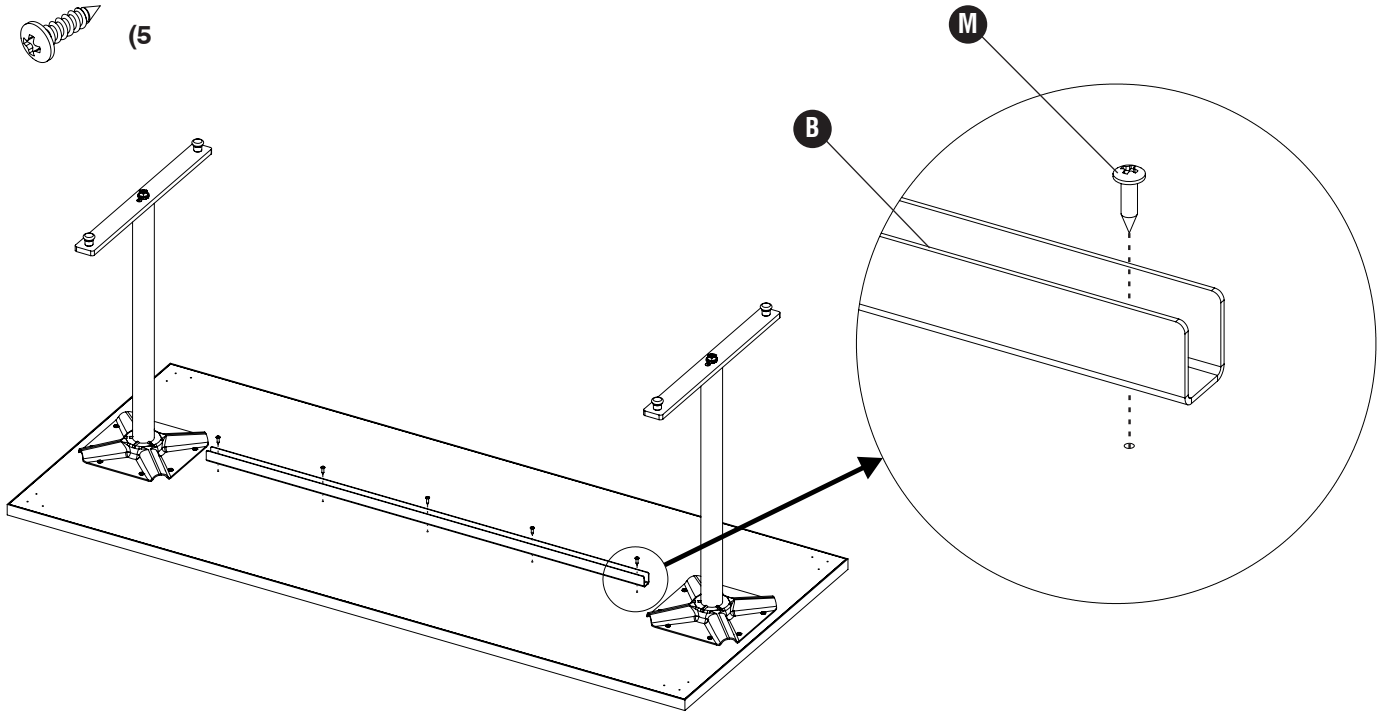

If a Stiffener is included, install using the 5 pilot holes in the center of the table.
Si un raidisseur est inclus, installez en utilisant les 5 trous pilotes au centre de la table.
Si se incluye un refuerzo, instale usando los 5 agujeros piloto en el centro de la tabla.

8

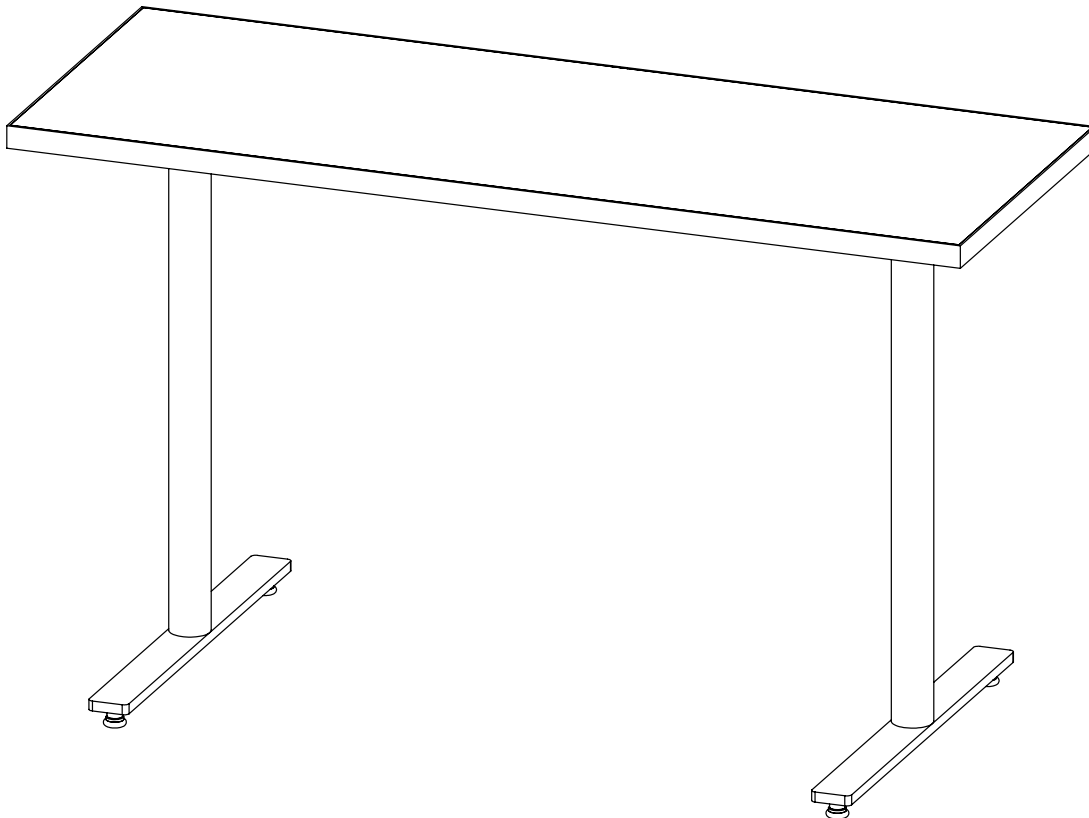

Flip the table over and adjust the levelers or casters to level the table. Periodically, re-tighten as needed.
Retournez la table et ajustez les niveleurs ou les roulettes pour niveler la table. Périodiquement, resserrez au besoin.
Voltee la mesa y ajuste los niveladores o ruedas para nivelar la mesa. Periódicamente, vuelva a apretar según sea necesario.