

Sorter and Sorter Shelving

INSTRUCTIONS

1. Place sorter with the top side down on a non-abrasive surface.
2. Locate plastic package containing double faced tape.
3. Clean both surfaces where double-faced tape is to be applied. Use any common cleaning agent to remove traces of grease or dirt. Surface must be dry before applying tape. Use only the 3M 4416 double-faced tape provided.
4. Refer to Figure 1. Apply tape as shown to bottom of sorter.

NOTE: It is the responsibility of the end user to follow all specific local, state and federal occupational safety and health standards applicable in the workplace. Extra installation support (anchors) may be necessary in some areas.

5. Install shelves per instructions on reverse side of this sheet.

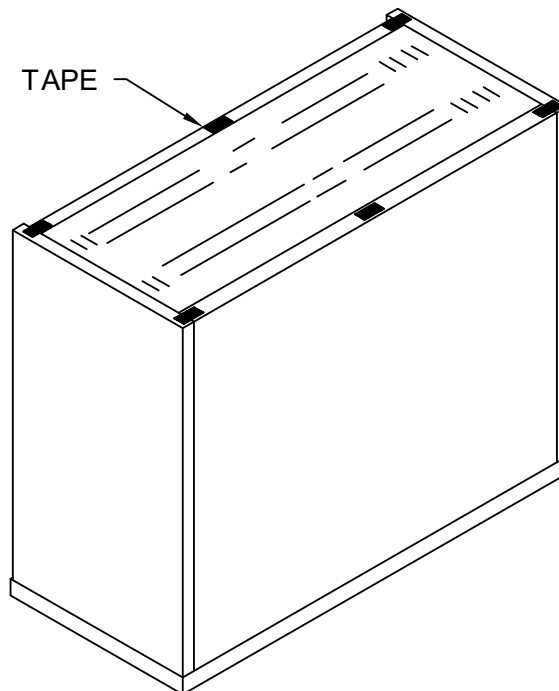

(1)

Sorter Shelving

INSTALLATION INSTRUCTIONS

1. Remove shelves and shelf supports from cartons. Keep same size shelves, supports, etc., together. (Shelves have beveled fronts with curved thumbcut; shelf supports have rows of loops).
2. Pre-configured sorter models use a combination of 11" wide and 12" wide shelves; shelves are either 12" or 15" deep. Refer to table below for the size and number of columns (of shelves) for each sorter width.

Pre-Configured Sorters -- Shelf Width

Sorter Width	Total # of Columns	# of Columns By Shelf Width
24"	2	2 Columns of 11" Wide Shelving
36"	3	2 Columns of 11" Wide / 1 Column of 12" Wide
48"	4	2 Columns of 11" Wide / 2 Columns of 12" Wide
60"	5	2 Columns of 11" Wide / 3 Columns of 12" Wide
72"	6	2 Columns of 11" Wide / 4 Columns of 12" Wide

3. To install shelf supports, begin at either end of sorter. Determine the location of each shelf support by measuring to the proper slot (in sorter bottom) with the selected shelf width -- or count by slots (1" apart) to find the correct one.
4. Shelf supports are installed with their feet in the bottom slots and the top tab inserted in the slotted strip protruding down from the inside top of the sorter. Make sure that the side of the shelf support with loops closest to the edge fits toward the front of the sorter.
5. After all the shelf supports are installed (11" or 12" apart as required), install the shelves as follows:
 - a. Pre-configured sorters (L" or G" follows sorter model number, i.e., SC6048G): the shelving provided with the sorter will allow for 3" high pockets, although you can install the shelves to create any height pocket on 1/2" intervals (loops are 1/2" apart).
 - b. Custom sorter configurations ("E" follows sorter model number, i.e., SC6048E): install shelves at intervals as desired by the specifier or customer.
6. Begin installing shelves at either the left or right end columns, starting at the bottom and working up the column until it is filled with shelves. Then move on to the next column until columns are filled with shelves.
7. The actual installation of shelves is simple. Begin by inserting each shelf carefully between the correct loops, keeping it level; slide it slowly inward a few inches. After it ramps upwards slightly, you can push it in more quickly all the way into the sorter, where it will drop into place (you may need to tap it lightly). If installed properly, it will be locked firmly in place so that if you try to pull it straight back out of the sorter, it will not move. (To remove the shelf from the cabinet, it must be lifted first, then pulled out).