

ASSEMBLY INSTRUCTIONS MAYTRIX™ LAN FURNITURE CORNER WORK SURFACE

NOTE: Please count and inspect all pieces before disposing of any carton or packing materials.

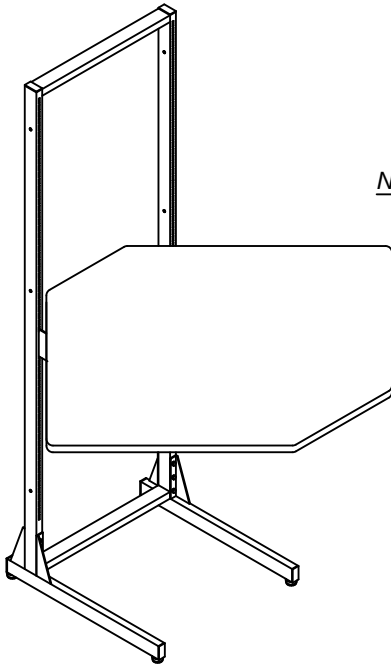

COMPONENTS: When ordering components, specific color and/or size information may be required. Contact a Safco Customer Service Representative. 1-888-971-6225

REF.#	QTY.	DESCRIPTION	PART No.	
1	1	R.H. SUPPORT BRACKET	A4567 **	
2	1	L.H. SUPPORT BRACKET	B3570 **	** Denotes Color Code
3	1	CORNER TOP	CALL ~**	~~Denotes Size

HARDWARE BAG (PART No. A4930) *for individual item, order that part number

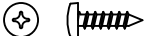
REF. #	QTY.	DESCRIPTION	PART No.	
E1	8	#10 X 3/4 SCREW	X11*	

1. Assemble Legs (B & C) to Frame per instructions included with those components.

2. Select height desired for Work Surface (D) and install Left and Right Brackets (E & F).

3. Position Work Surface (D) on brackets. Engage all work surface Screws (H), but do not tighten, this will aid with bracket / work surface alignment.

When aligned, tighten all screws.

