

4-POST SHELVING

(See Pages 1 thru 4)

COMPONENTS:

1. Uprights
2. Bottom Shelf Support
3. Standard Shelf Support
4. Non-slotted Shelf Canopy
5. Slotted Shelf
6. Shelf Reinforcement
7. Common Stop

TOOLS REQUIRED:

1. Rubber Mallet

HEAVY DUTY 4-POST SHELVING

(See Pages 1, 5 & 6)

COMPONENTS:

1. Uprights
2. Bottom Shelf Support
3. X-ray Shelf Support
4. Non-slotted Shelf Canopy
5. Slotted Shelf
6. X-ray Std./Btm. Shelf Reinforcement
7. Common Stop

4-POST ACCESSORIES

(See Pages 7 thru 16)

COMPONENTS:

1. Upper and lower spreaders
2. Shelf reinforcements
3. Slide attachment bracket kits
4. Drawers
5. Drawer lock
6. Partition supports and partitions
7. Support bar
8. 18" Shelves
9. 36" Shelves

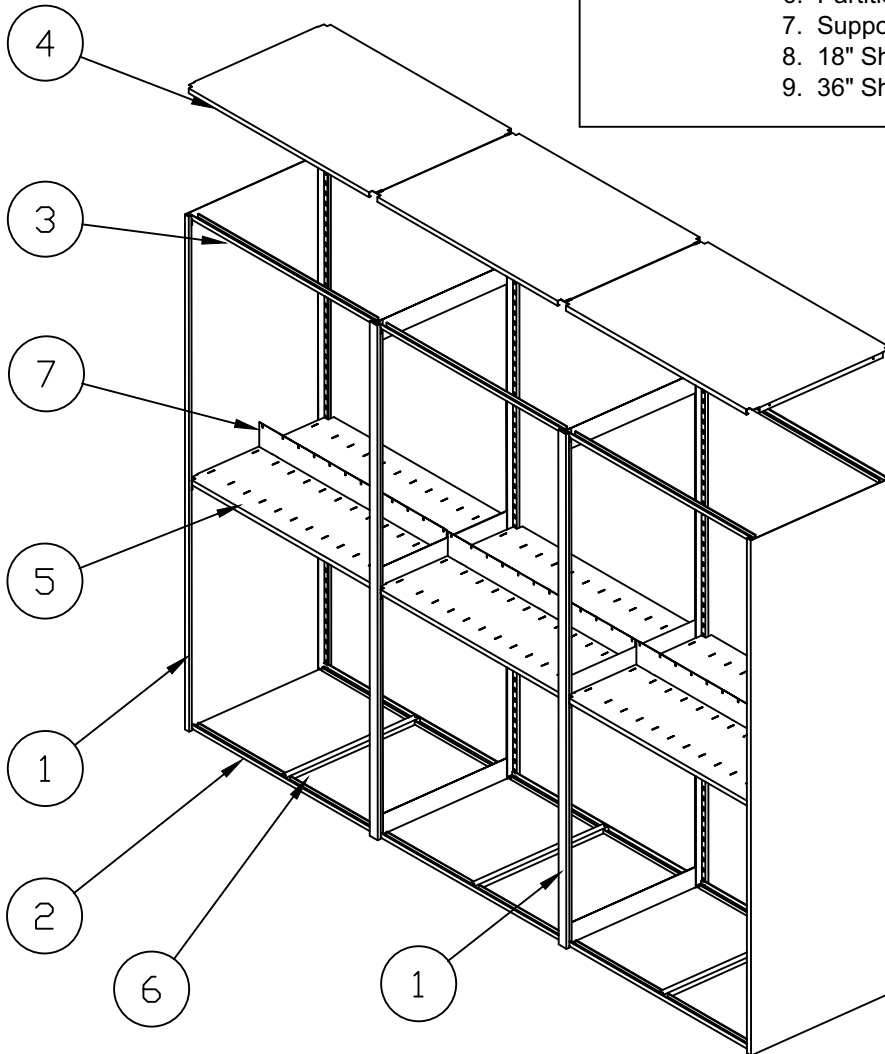

The components of the basic 4-Post System are:

1. **VERTICAL UPRIGHTS:** Three styles are used:

- A.) Open 'T'
- B.) Closed 'T'
- C.) Closed 'L'

Closed 'L' uprights are located at either end of a 4-Post range. Open and Closed 'T' are located internally in a 4-Post range. Each style contains tapered slots vertically along the uprights to accept the shelf supports which are positioned horizontally. The narrow portion of the tapered slots must face downward. Tapered slots are at 1-1/2" vertical spacing.

Crowned Tapered Slots in each upright are identification marks that will aid in the even spacing of shelves and accessories.

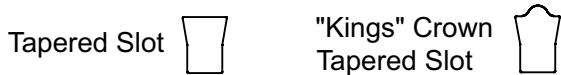

2 & 3. **SHELF SUPPORTS:** Two styles are used:

- A.) Standard shelf supports
- B.) Bottom shelf supports

The supports are inserted into the slots of the vertical upright to form the horizontal support for the shelf. Standard shelf supports are Pebble Gray in color. The bottom shelf supports are Graphite in color and are used only at the bottom of the unit. Supports should be secured into place with a rubber mallet.

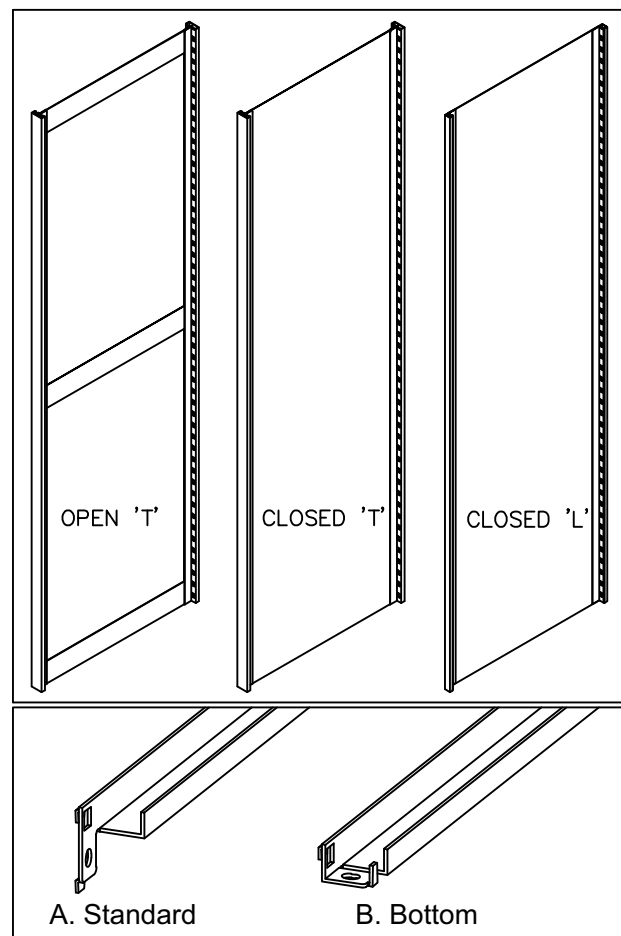

4. **SHELF REINFORCEMENT BARS:**

Reinforcements are used on "Double Face Shelves (24" and 30" shelving only). These bars are positioned across the shelf supports to add strength to the shelf. Shelf reinforcement quantities are illustrated in the matrix to the right. 

NOTE: Adjust the reinforcement position if it interferes with shelf slots.

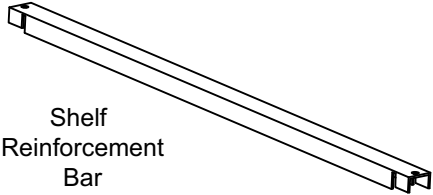

Shelf Reinforcement Bar

Shelf Depth	Shelf Width				
	24"	30"	36"	42"	48"
18"	1	1	1	1	2
24"	1	1	1	1	2
30"	2	2	2	2	2
36"	2	2	2	3	3

5 & 6. **SHELVES:** three styles are used:

- A.) Single Face Slotted.
Depth is either 12" or 15". Two rows of slots exist for divider installation. Three slots are also located in the back of the shelf for the center/back stop installation.
- B.) Double Face Slotted.
Depth is either 23" or 30". Four rows of slots exist for the divider installation. Three slots are also located in the middle of the shelf for the center/back stop installation.
- C.) Single & Double Face Non-slotted.
Shelves are positioned on the shelf supports and also used as the canopy top which is typically a non-slotted shelf.

7. **COMMON STOPS:**

Placed in the back of single face and middle of double face shelves. Held in place by dividers.

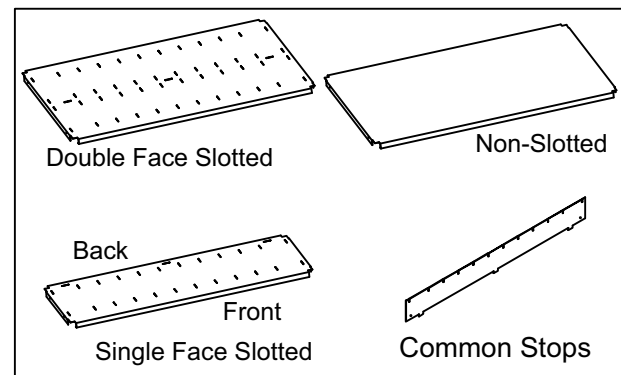

4-POST Reference Shelf

Assembly Instructions

COMPONENTS:

1. Reference Shelf Assembly (1)
2. Stabilizer Bracket (1)
3. R.H. End Bracket Slide Assembly (1)
4. L.H. End Bracket Slide Assembly (1)
5. 10-32 x 3/8 Pan Head Screw (4)
6. 10-32 KEPS Nut (4)
7. 1/4-20 x 1/2 Hex Head Screw (2)
8. 1/4-20 KEPS Nut (2)

Secure stabilizer bracket to reference shelf end with #10-32 x 1/2 screws and KEPS nut. DO NOT TIGHTEN hardware until reference shelf is installed.

Slide the reference shelf on the end bracket slide assemblies, notches are provided on the back side of the shelf. Slide the shelf back until the front of the slide is resting with the flat fold of the shelf.

Now tighten the stabilizer bracket hardware. Be sure that the slide brackets are parallel.

Pullout Reference Shelf Model numbers:

Model:	W	H
EF24RS	24"	12"
EF30RS	30"	12"
EF36RS	36"	12"
EF42RS	42"	12"
EF48RS	48"	12"

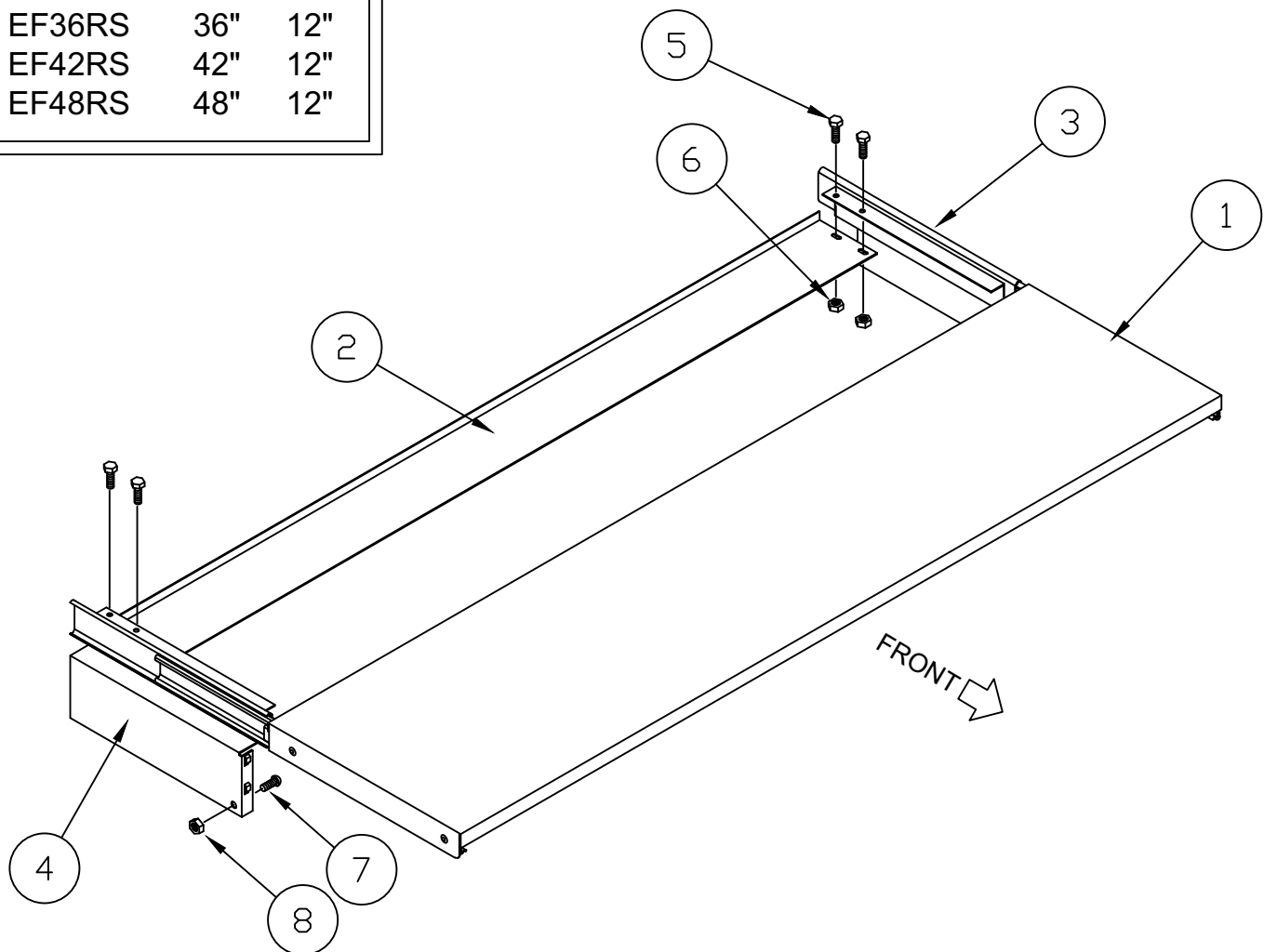

When a Pull-Out Reference Shelf is used,

Set each reference shelf end bracket assembly into slots in upright.

Using the holes in the bracket as pilot holes, drill 2 holes (1/4" diameter) into the upright. Secure the bracket to the upright with 1/4-20 x 1/2 screw and nut. Do both brackets.

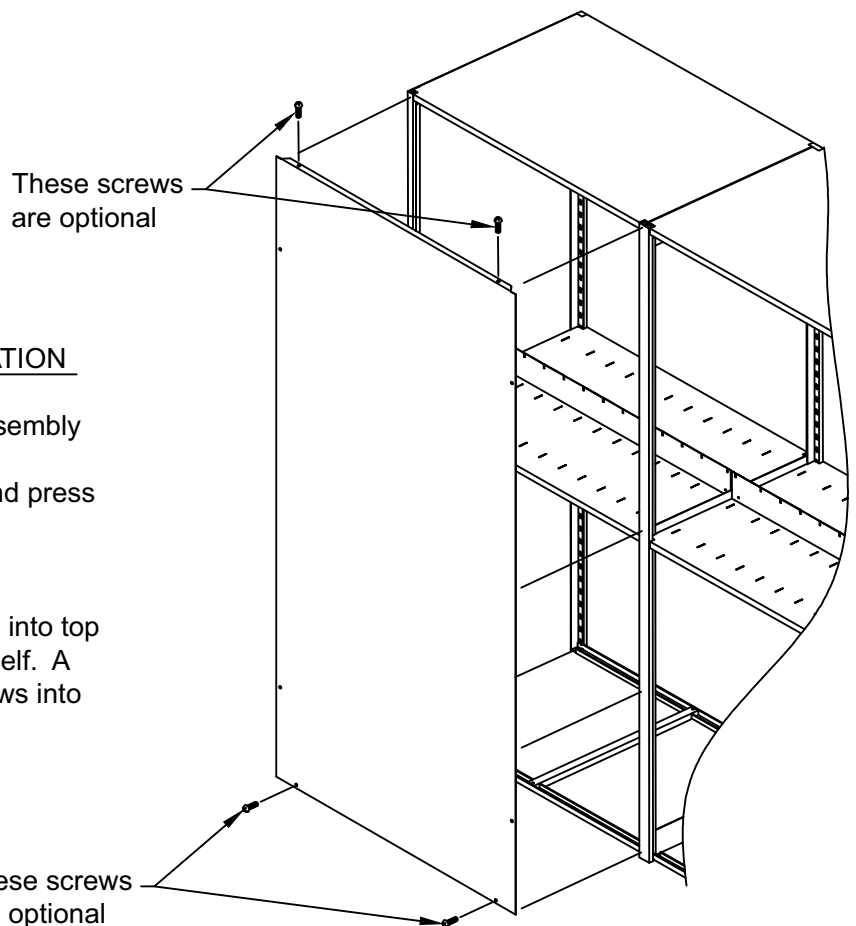
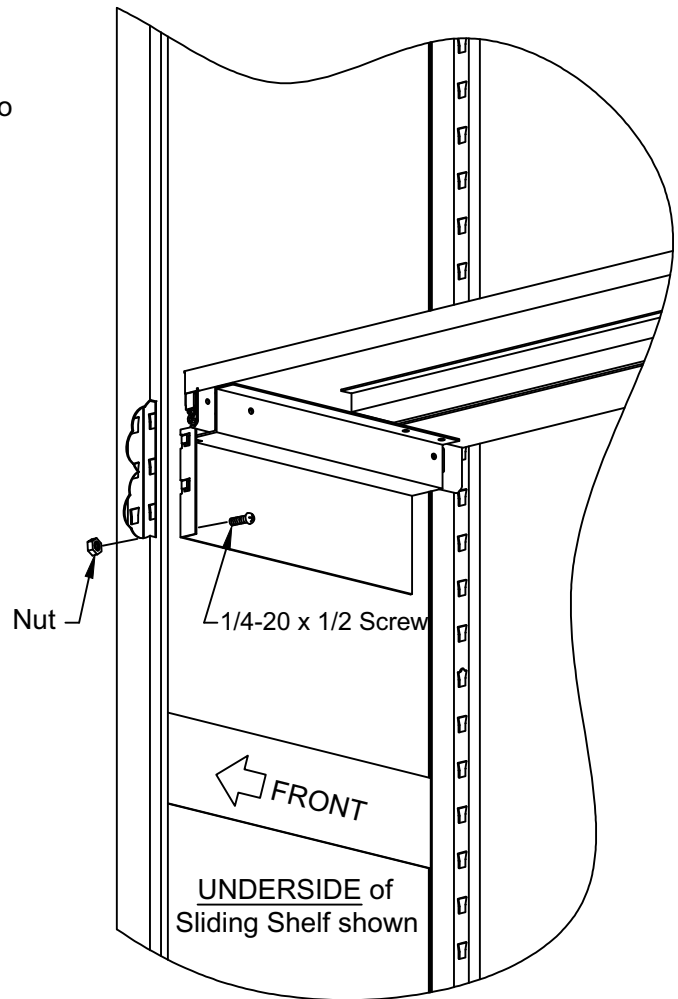
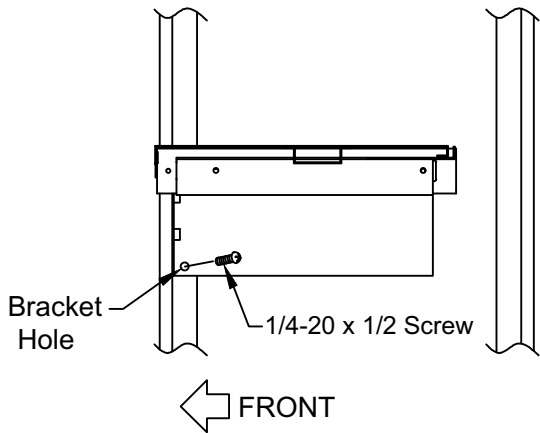

BACK PANEL or CENTER PANEL INSTALLATION

Rest the panel flange on top of the 4-Post assembly and center the panel side to side. Peel away protective film from tape on inside of panel and press firmly into position.

Optional: Attach the panel using (4) #10 TEK self-drilling screws. Located at the top flange into top shelf and along the bottom into the bottom shelf. A power driver must be used to thread the screws into the uprights.

Heavy Duty Specifications:

86" tall uprights provide for (3) 15.125" openings and (2) 16.625" openings.

Shelving to hold 8 pounds per linear filing inch.
 48"x18" shelf = 384 pounds per shelf
 48"x36" shelf = 768 pounds per shelf

The components of the basic Heavy Duty Shelving System are:

1. VERTICAL UPRIGHTS: Three styles are used:

- A.) Open 'T'
- B.) Closed 'T'
- C.) Closed 'L'

Closed 'L' uprights are located at either end of a 4-Post range. Open and Closed 'T' are located internally in a 4-Post range. Each style contains tapered slots vertically along the uprights to accept the shelf supports which are positioned horizontally. The narrow portion of the tapered slots must face downward. Tapered slots are at 1-1/2" vertical spacing.

Crowned Tapered Slots in each upright are identification marks that will aid in the even spacing of shelves and accessories.

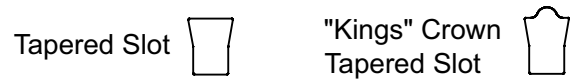

2 & 3. SHELF SUPPORTS: Two styles are used:

- A.) Heavy Duty shelf supports
- B.) Bottom shelf supports

The supports are inserted into the slots of the vertical upright to form the horizontal support for the shelf. The bottom shelf supports are used only at the bottom of the unit. Supports should be secured into place with a rubber mallet.

NOTE: Heavy Duty shelf supports are 1/2" deeper than the bottom Heavy Duty shelf supports.

4. SHELF REINFORCEMENT BARS: Two styles are used:

- A.) Heavy Duty shelf reinforcement (deep channel)
- B.) Bottom shelf reinforcement (shallow channel)

Reinforcements are used on all Heavy Duty shelves with the exception of the canopy top. These bars are positioned across the shelf supports to add strength to the shelf. Shelf reinforcement quantities are illustrated in the matrix at the right. 

Adjust the reinforcement position if it interferes with shelf slots.

NOTE: Heavy Duty shelf reinforcements are 1/2" deeper than the Heavy Duty bottom shelf reinforcements.

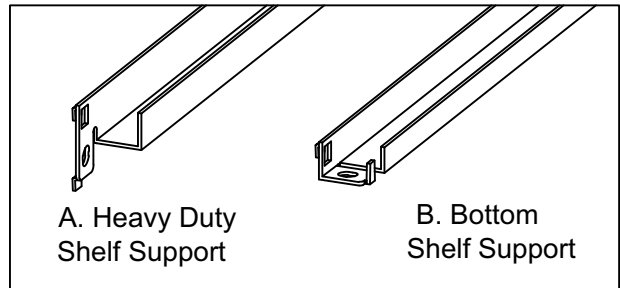
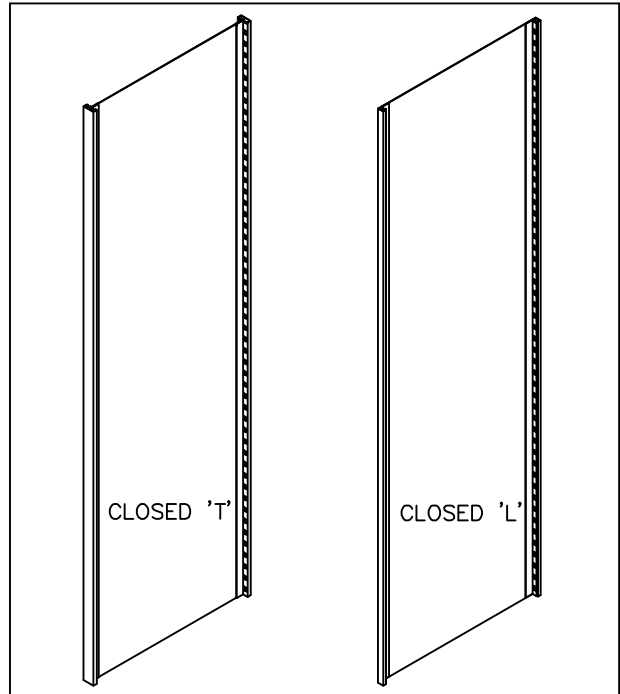

		Shelf Width				
		24"	30"	36"	42"	48"
Shelf Depth	18"	2	2	2	2	2
	36"	3	3	3	3	3

5 & 6. **SHELVES:** Two styles are used:
 A.) Single Face Slotted
 Depth is 18". Two rows of slots exist for divider installation. Three slots are also located in the back of the shelf for the center/back stop installation.
 B.) Double Face Slotted
 Depth is 36". Four rows of slots exist for the divider installation. Three slots are also located in the middle of the shelf for the center/back stop installation.
 C.) Single & Double Face Non-slotted
 Shelves are positioned on the shelf supports and also used as the canopy top which is typically a non-slotted shelf.

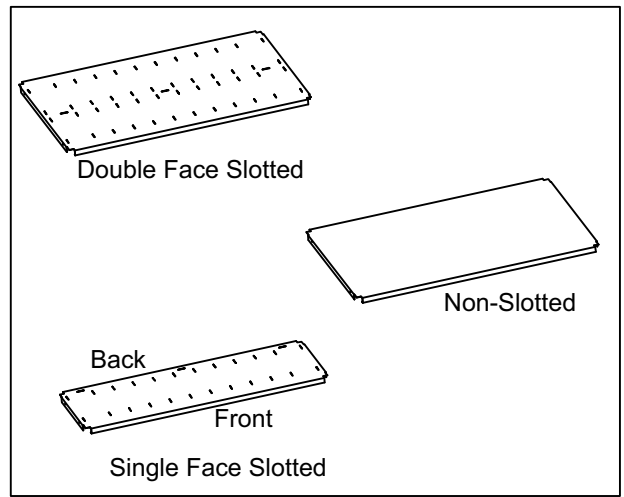

7. **COMMON STOPS:**
 Placed in the back of single face and middle of double face shelves. Held in place by dividers.

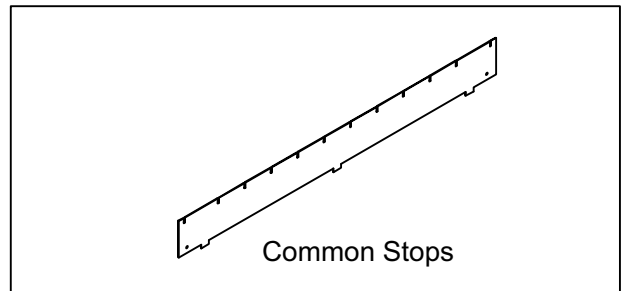

Back / Center Panel Assembly Instructions (Optional Item)

Back Panel (indicated by offsets running the long length of the panel) & Center Panel (no offsets) installation

Rest the panel flange on the top of the 4-Post assembly and center the panel side to side. Peel away protective film from tape on inside of panel and firmly press into position.

Optional: Attach the panel using (4) #10 TEK self-drilling screws located at the top flange into top shelf and along the bottom into the bottom shelf (hardware bag of 30 screws is provided). A power driver must be used to thread the screws into the uprights. Verify with end user if they would like the screws installed into the panel.

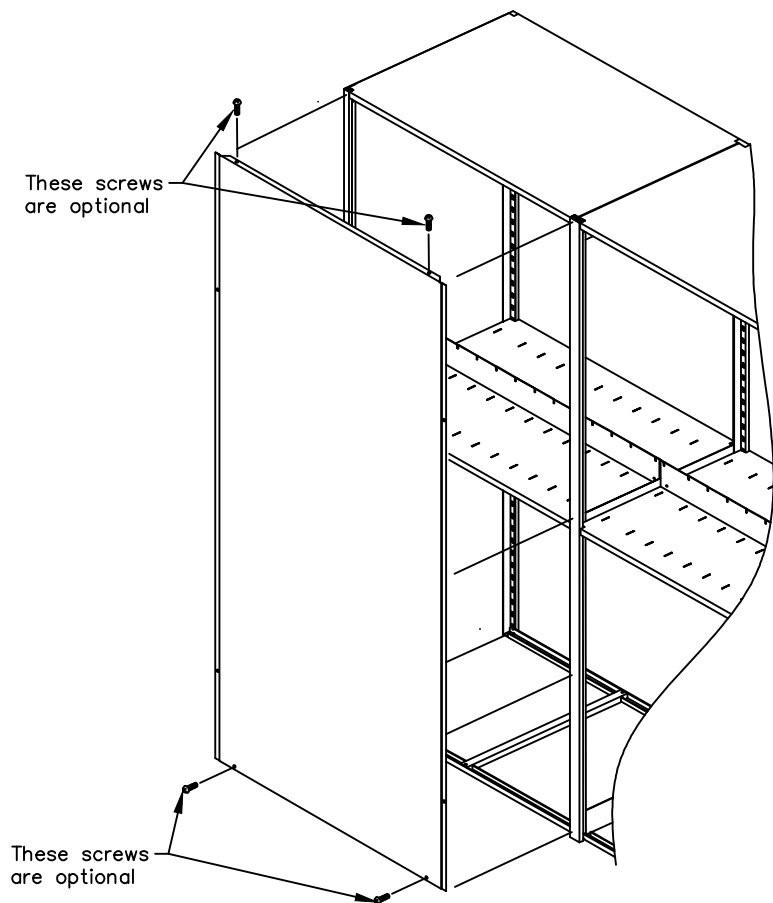

Rollout Drawer Assembly / Installation

UPPER AND LOWER SPREADERS: When specifying roll out drawers you will use two lower spreaders and two upper spreaders for each 4-Post unit. The lower spreader will replace the lower shelf support, its additional height will help to stabilize the unit. The upper spreader would replace a shelf support in the area above the top drawer, again the additional height will help to stabilize the unit. Both upper and lower spreaders are installed the same as our standard shelf support. Place the tabs in the holes in uprights and use a rubber mallet to seat in place.

Domed slots will assist with horizontal placement of components and are spaced approximately 10-1/2" apart.

When attaching shelving to the floor use (4) 1/4" masonry wedge anchors for concrete or (4) 1/4" wood screws when going into another material.

Not recommended for mounting on a carpeted floor.

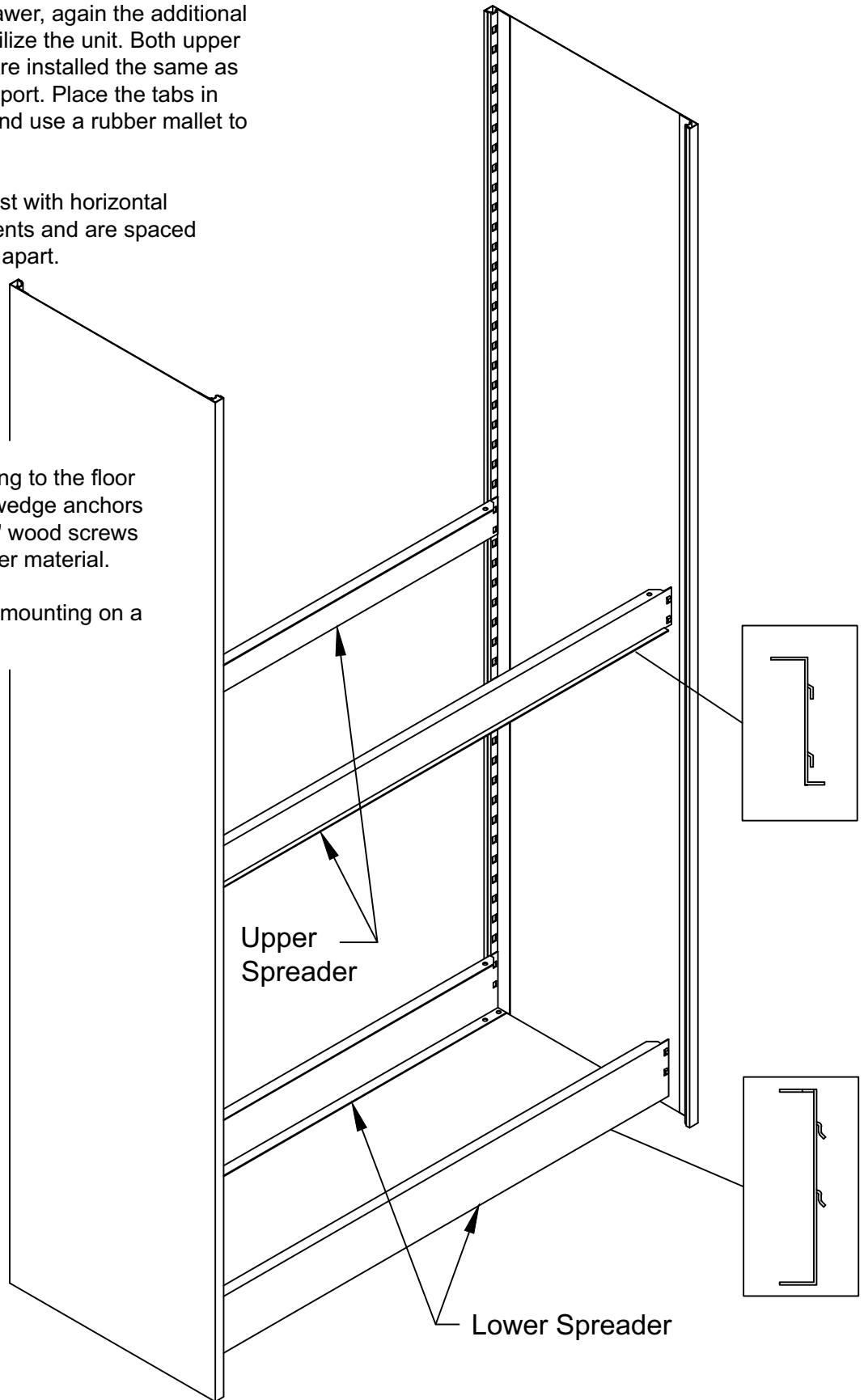

UPPER SPREADER	
30"	- 859301
36"	- 859302
42"	- 859303
48"	- 859304

LOWER SPREADER	
30"	- 859201
36"	- 859202
42"	- 859203
48"	- 859204

SHELF REINFORCEMENTS: A special shelf reinforcement is used above the upper spreader, all other shelves will use the Heavy Duty bottom shelf reinforcements (F18SRA, F36SRA)
 Shelf reinforcement quantities are illustrated in the matrix below.

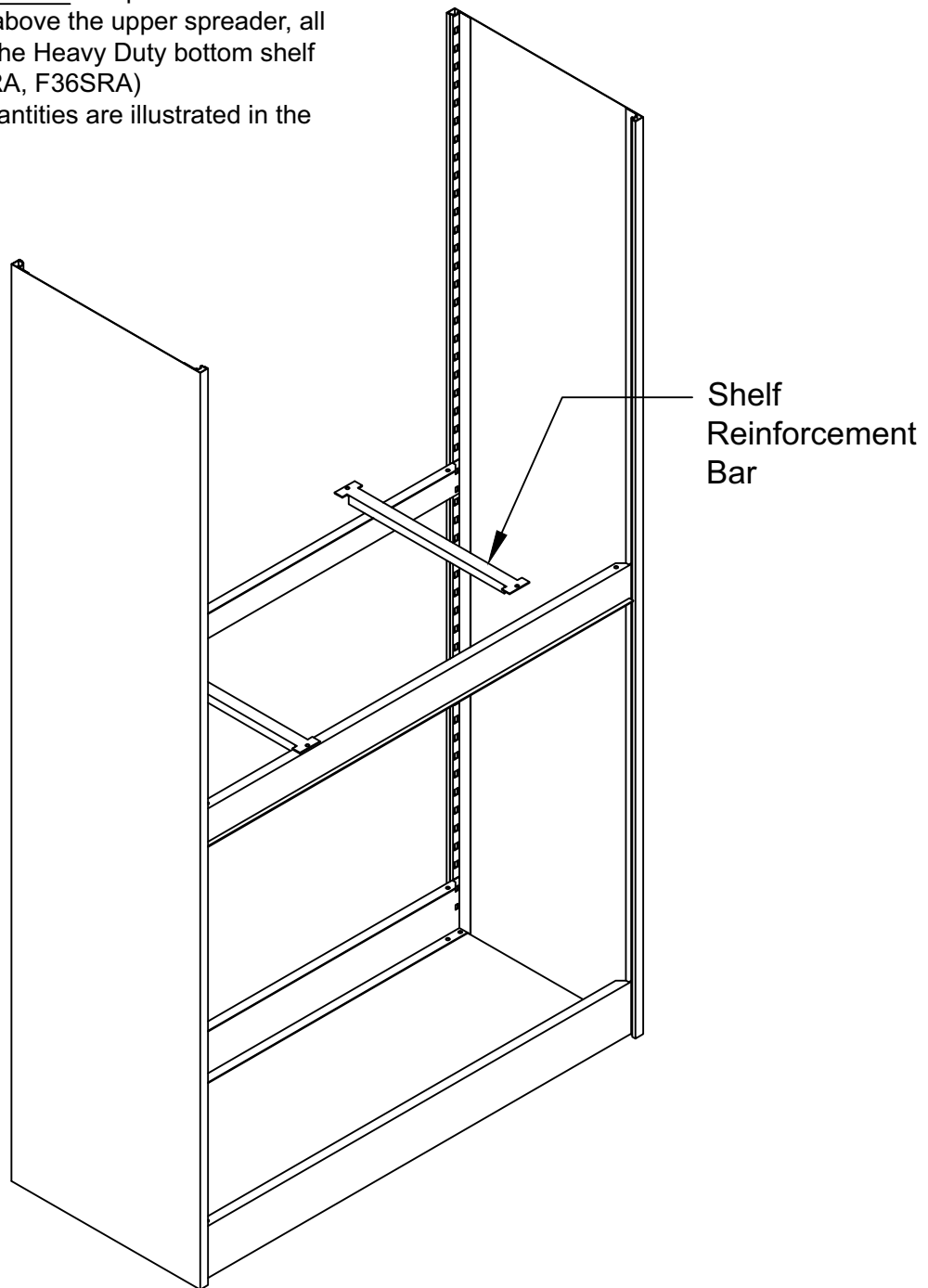

		Shelf Width				
		24"	30"	36"	42"	48"
Shelf Depth	18"	2	2	2	2	2
	36"	3	3	3	3	3

18" Bracket / Slide Installation

SLIDE ATTACHMENT BRACKET KITS :

These kits include four brackets for both the 18" and 36" 4-Post. The 18" bracket kit will include two slides. The 36" bracket kit will include four slides.

The brackets are attached much like the shelf supports. The two pieces are slid together and the tabs get located into the slots in the vertical uprights and are seated in place with a rubber mallet. After they are seated four screws get added to each bracket, two for bracket stops and the other two to complete bracket assembly.

A hardware kit (707900) with eight screws and six brackets stops is included to complete each bracket kit.

INSTALLATION OF BRACKETS FOR ROLLOUT DRAWERS: See page 10

Replacement Parts:

- 860200R - BRACKET ASM. 18"/36" LH
- 860300R - BRACKET ASM. 18"/36" RH
- 860400R - BRACKET ASM. 18" LH
- 860500R - BRACKET ASM. 18" RH
- 707900R - HDWR KIT 4 POST ACC

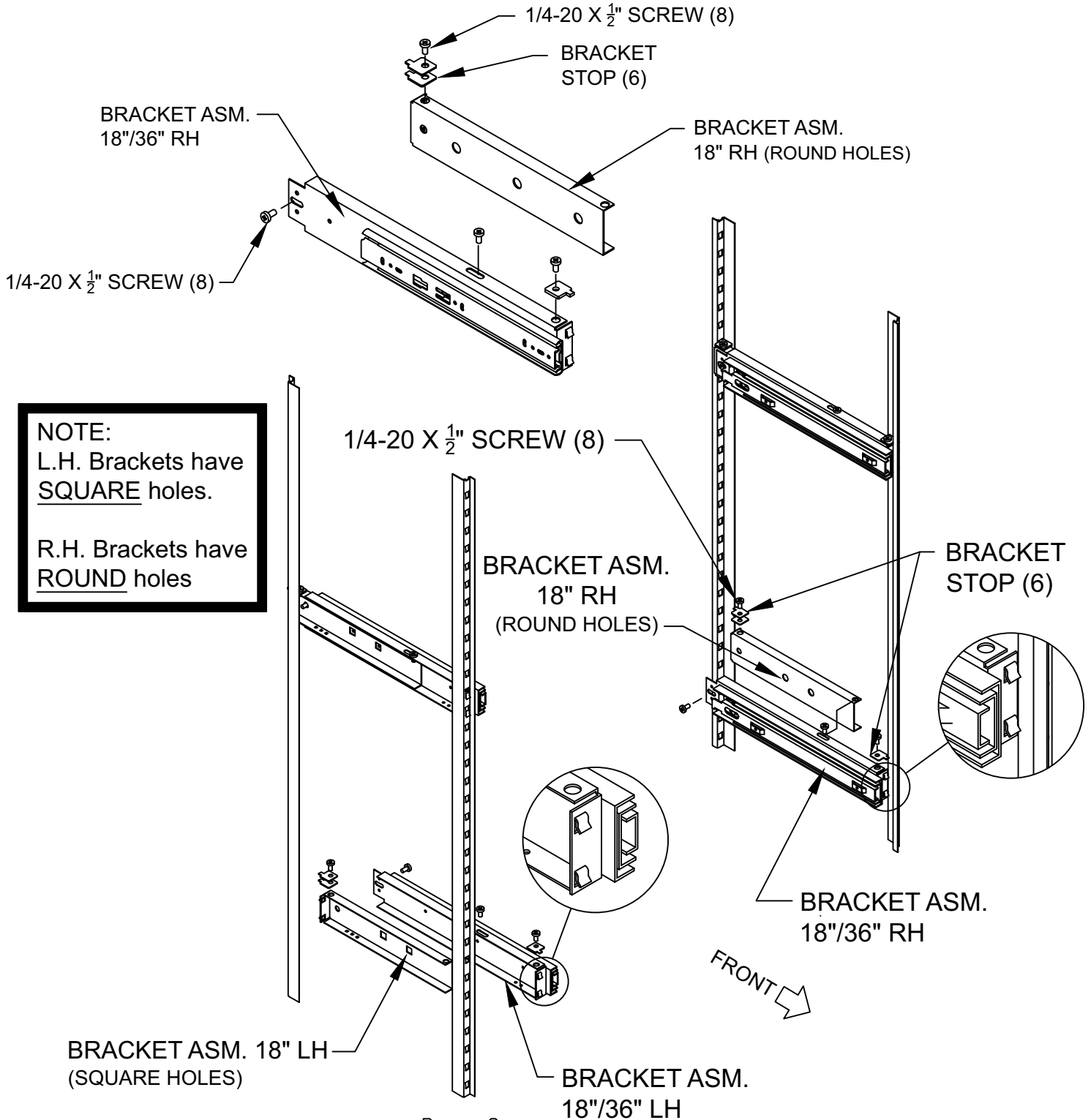

36" Bracket / Slide Installation

INSTALLATION OF BRACKETS FOR ROLLOUT DRAWERS.

For proper spacing and installation of drawers, brackets should be installed from the bottom up. The location of the bottom drawer and remaining brackets will be different depending on the height of the drawer being installed. Each bracket has two tabs on each end of each bracket assembly that get installed into corresponding open slots on the four post upright. Domed slots will assist with horizontal placement of components and are spaced approximately 10-1/2" apart.

Replacement Parts:	
860000R	- BRACKET ASM. 36" LH
860100R	- BRACKET ASM. 36" RH
860200R	- BRACKET ASM. 18"/36" LH
860300R	- BRACKET ASM. 18"/36" RH
707900R	- HDWR KIT 4 POST ACC

BOTTOM DRAWER BRACKET INSTALLATION :

- 10.5" drawer (use 3rd & 4th slots above lower spreader)
- 6" drawer (use 2nd & 3rd slots above lower spreader)
- 4.5" drawer (use 1st & 2nd slots above lower spreader)

REMAINING DRAWER BRACKET INSTALLATION:

- 10.5" drawer (use 3rd & 4th slots above drawer front)
- 6" drawer (use 2nd & 3rd slots above drawer front)
- 4.5" drawer (use 1st & 2nd slots above drawer front)

NOTE:
L.H. Brackets have SQUARE holes.
R.H. Brackets have ROUND holes

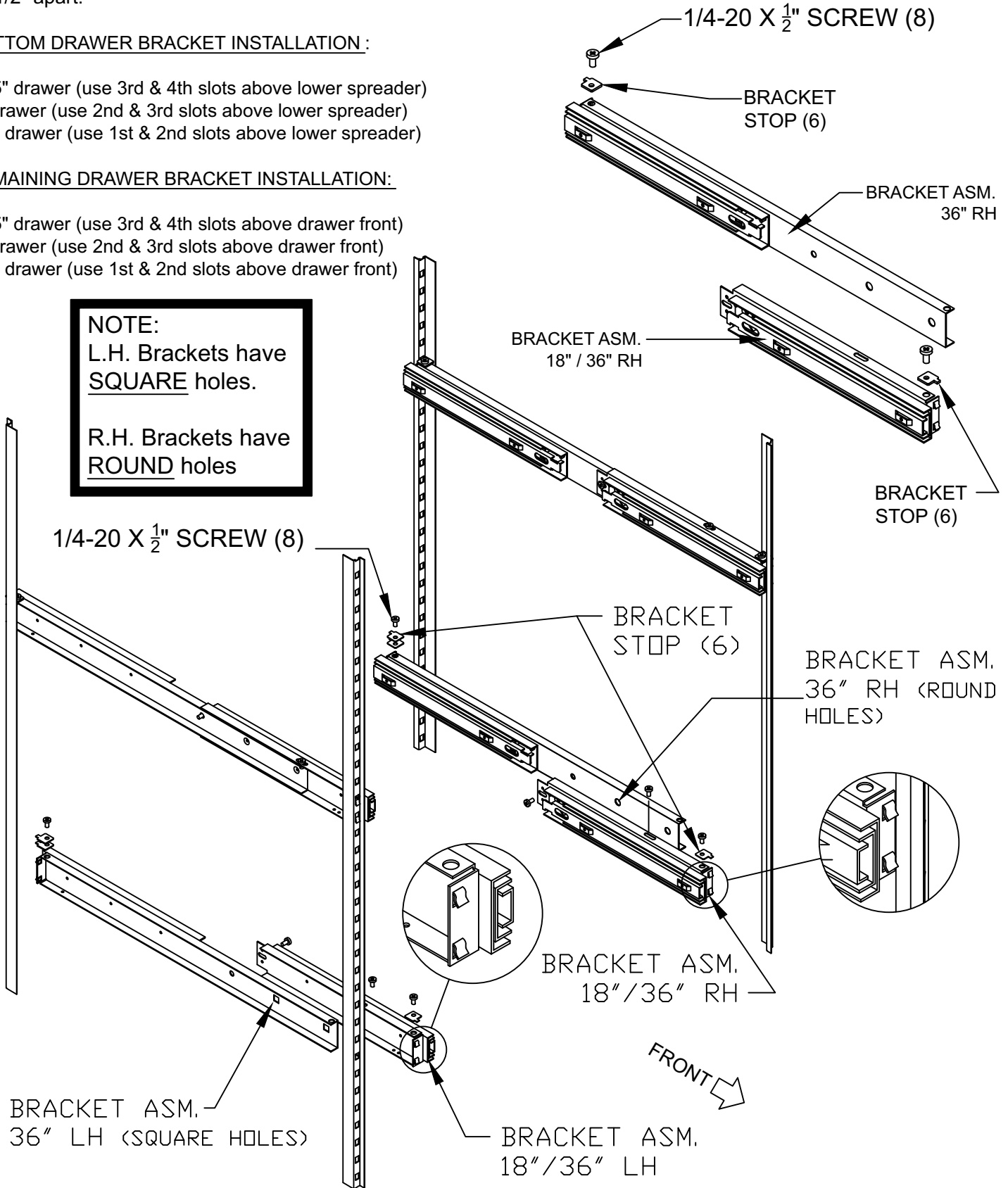

DRAWERS: Drawers are available in three heights: 4.5", 6", and 10.5" and in four widths, 30", 36", 42" and 48" and depths of all are 15.738".

The drawers are available only for the 18" and 36" deep 4-Post units.

4-Post drawers can be configured using any of the different drawer heights in each of the different cabinet widths.

To install drawers place tabs in drawers into slots on the slides. (see picture)

4.5 Height Roll-out Drawers:

- EF2415RD45 – EFA DRAWER 24" X 15" X 4.5"
- EF3015RD45 – EFA DRAWER 30" X 15" X 4.5"
- EF3615RD45 – EFA DRAWER 36" X 15" X 4.5"
- EF4215RD45 – EFA DRAWER 42" X 15" X 4.5"
- EF4815RD45 – EFA DRAWER 48" X 15" X 4.5"

6.0 Height Roll-out Drawers:

- EF2415RD6 – EFA DRAWER 24" X 15" X 6"
- EF3015RD6 – EFA DRAWER 30" X 15" X 6"
- EF3615RD6 – EFA DRAWER 36" X 15" X 6"
- EF4215RD6 – EFA DRAWER 42" X 15" X 6"
- EF4815RD6 – EFA DRAWER 48" X 15" X 6"

10.5 Height Roll-out Drawers:

- EF2415RD105 – EFA DRAWER 24" X 15" X 10.5"
- EF3015RD105 – EFA DRAWER 30" X 15" X 10.5"
- EF3615RD105 – EFA DRAWER 36" X 15" X 10.5"
- EF4215RD105 – EFA DRAWER 42" X 15" X 10.5"
- EF4815RD105 – EFA DRAWER 48" X 15" X 10.5"

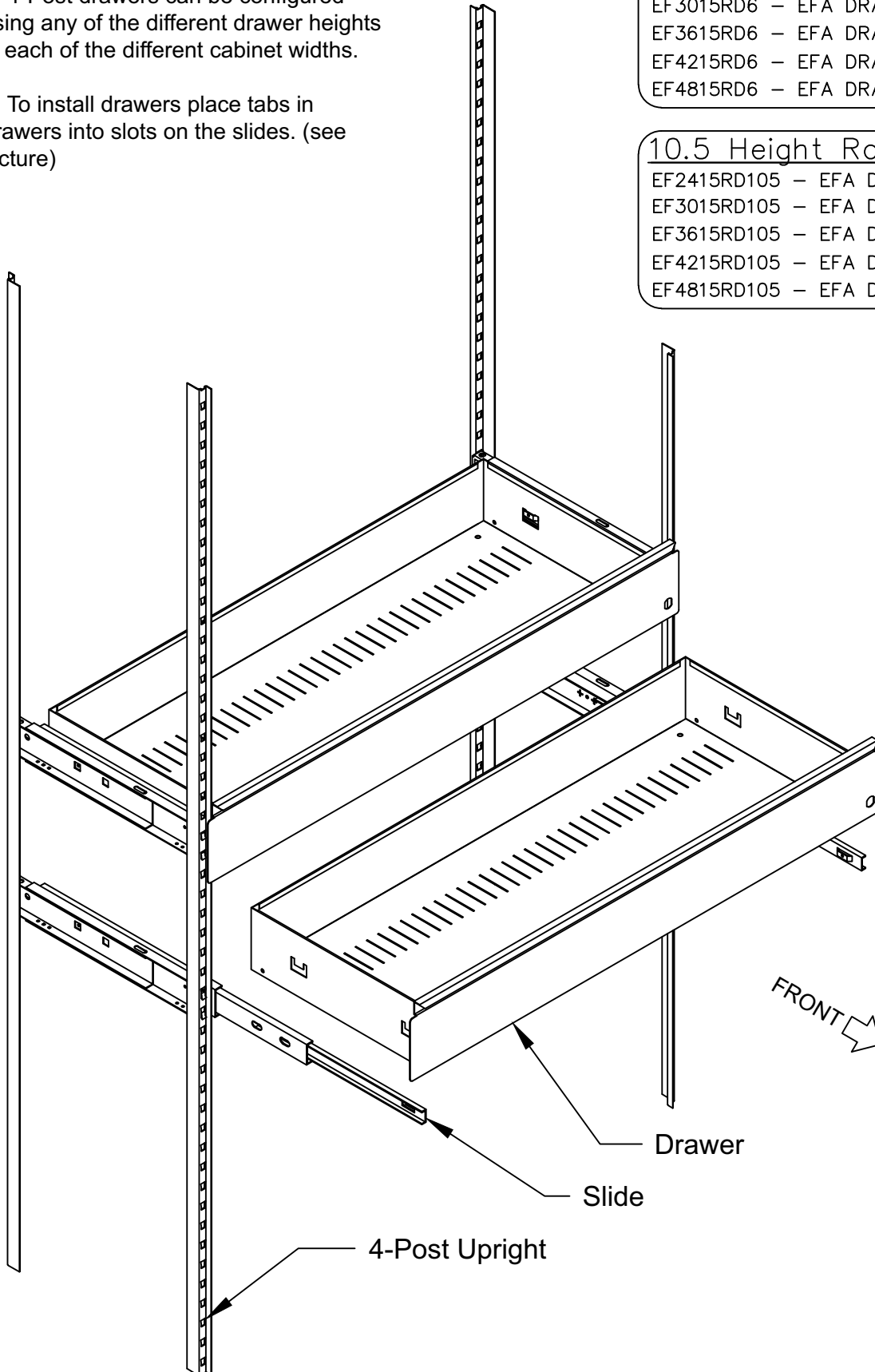

DRAWER LOCK: There is a cam lock for the 6" and 10.5" drawers. To install you must carefully remove the knockout on the lower right hand side of drawer face. Using a hammer and a screw driver, tap on the areas not retained going back and forth till knockout drops out.

Remove nut from lock, add rotation stop washer, cam and screw to the lock and feed through hole in drawer, replace the nut and tighten. Lock cam should be in the down position and turn 90 degrees to the lock position. The lock should catch on the inside of the upright but may require a slight adjustment.

Replacement Parts:
FPALOCKREPL - Lock Assembly FPA

NOTE:
4-Post drawers are
keyed alike from factory

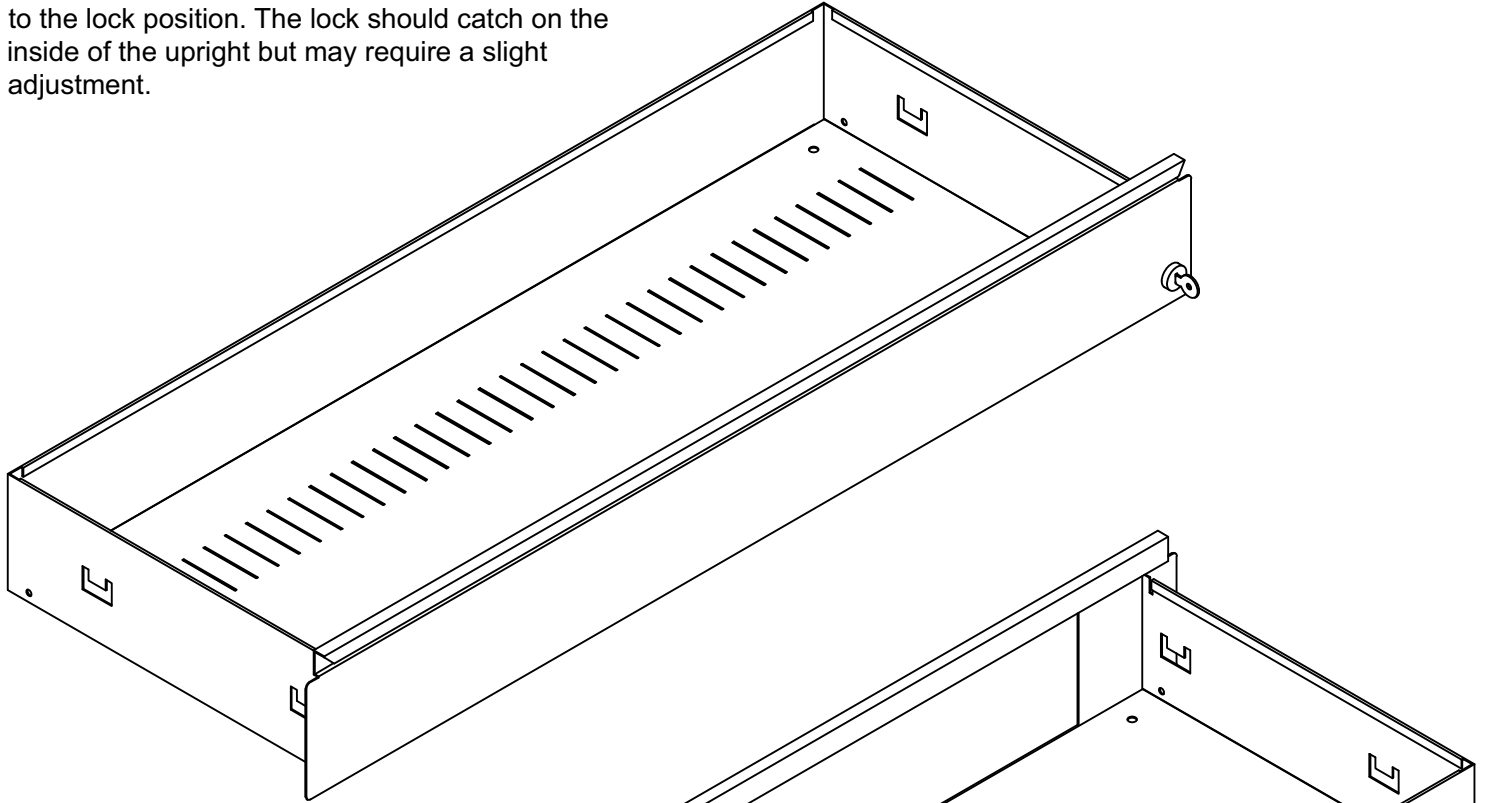

Lock assembly shown
Locked and Unlocked

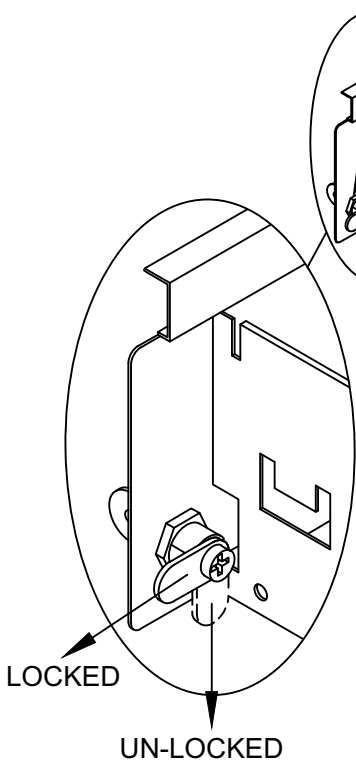

PARTITION SUPPORTS: If partitions are going to be used, a partition support will be required at the front of each drawer. This option is available only on the 4.5" and 6" drawers, it is not an option on the 10.5" drawer.

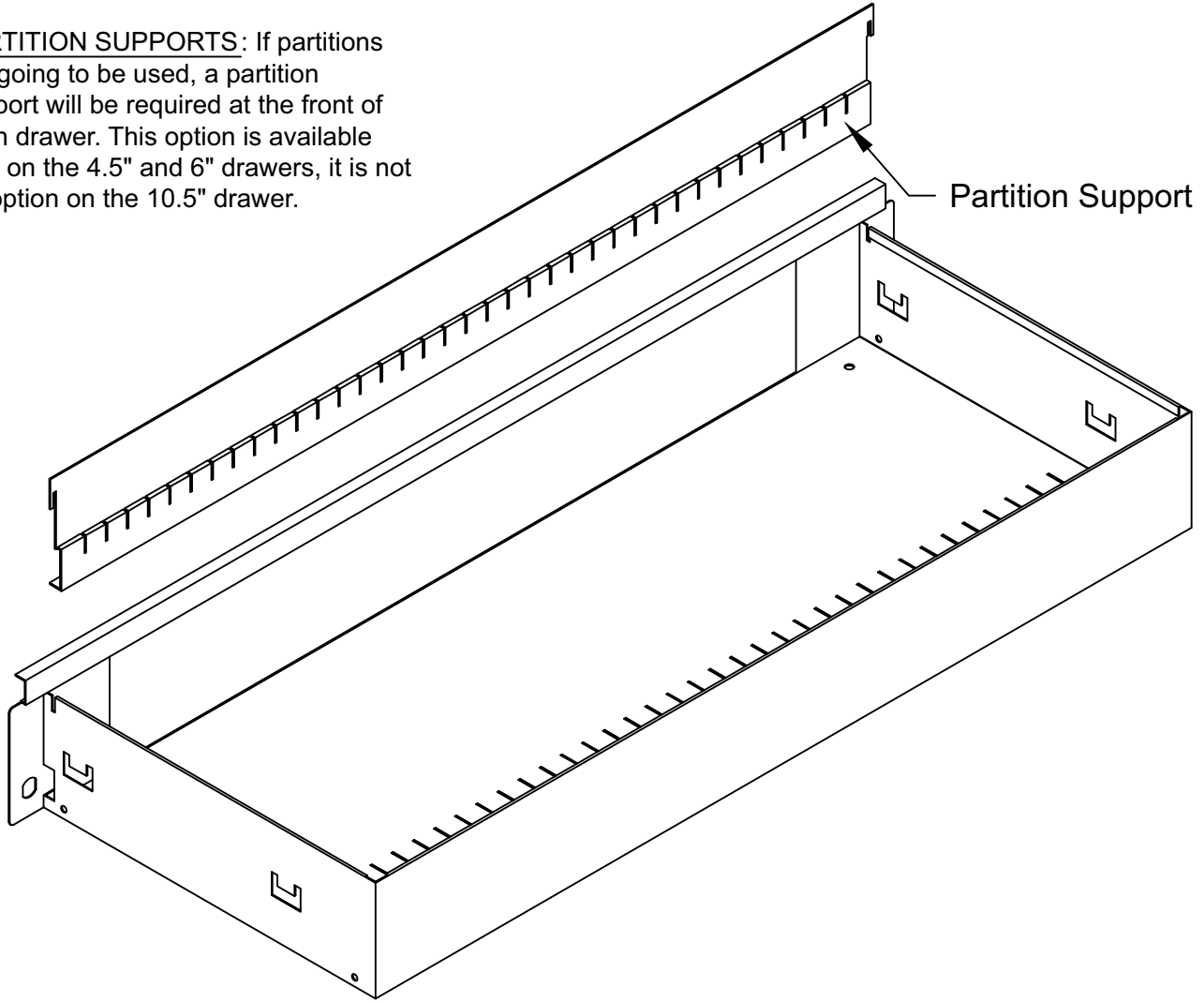

PARTITIONS: There are two different heights used, the 4.5" and the 6". They are used along with the partition supports for the separation of media. They will hook into slots in the partition support at the front and into the slots in the drawer bottom.

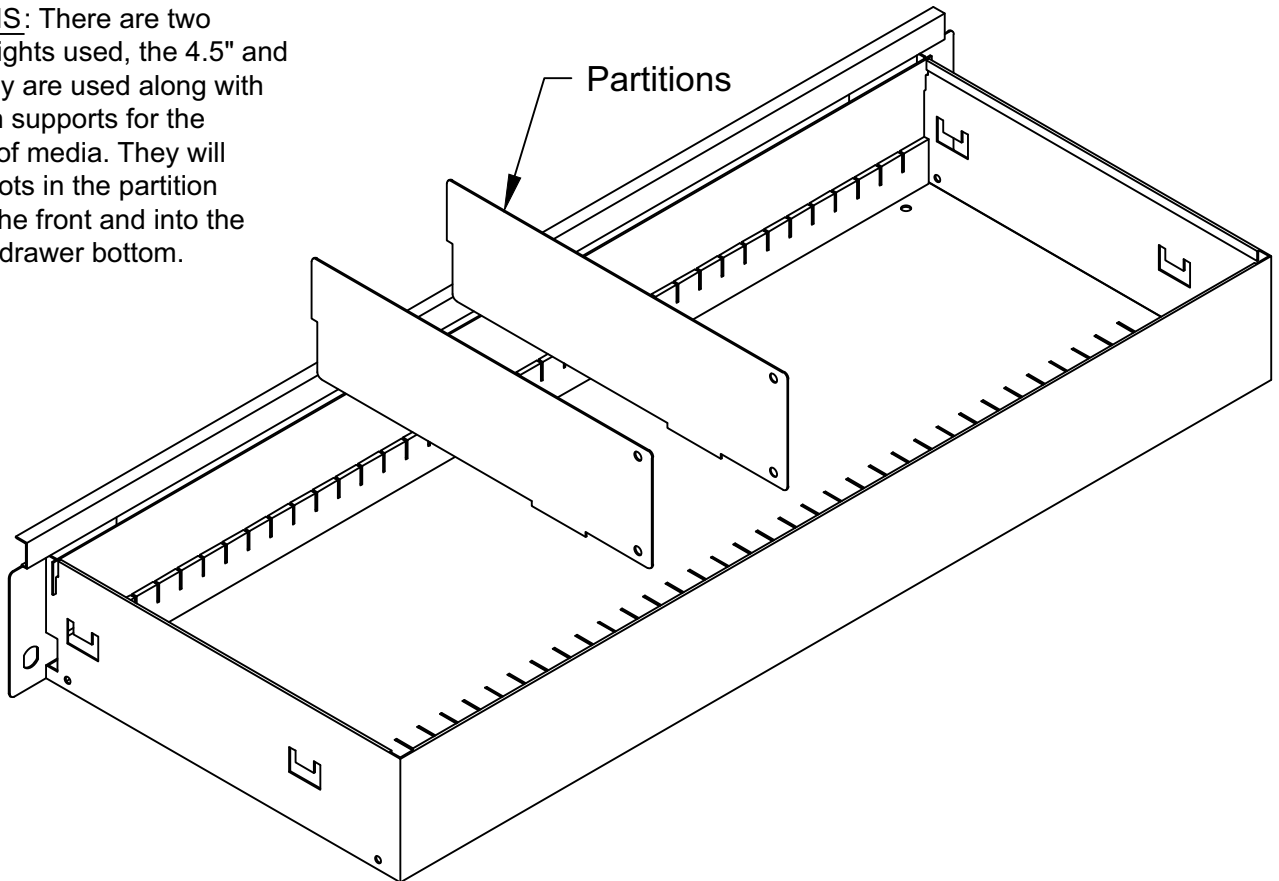

SUPPORT BAR: A support bar is required at the front of the 10.5" drawer when hanging files are going to be used. It hooks into the slots at the top front of the drawer.

SUPPORT BAR:

- 86605801 – SUPPORT BAR 24"
- 86605802 – SUPPORT BAR 30"
- 86605803 – SUPPORT BAR 36"
- 86605804 – SUPPORT BAR 42"
- 86605805 – SUPPORT BAR 48"

FELT PADS: The hardware kit includes 4 felt pads which may be added to the back of the drawer fronts. The pads should be placed near the edge of the drawer approximately 1" up from the bottom or 1" above the lock if lock is used and 1" down from the top (as shown).

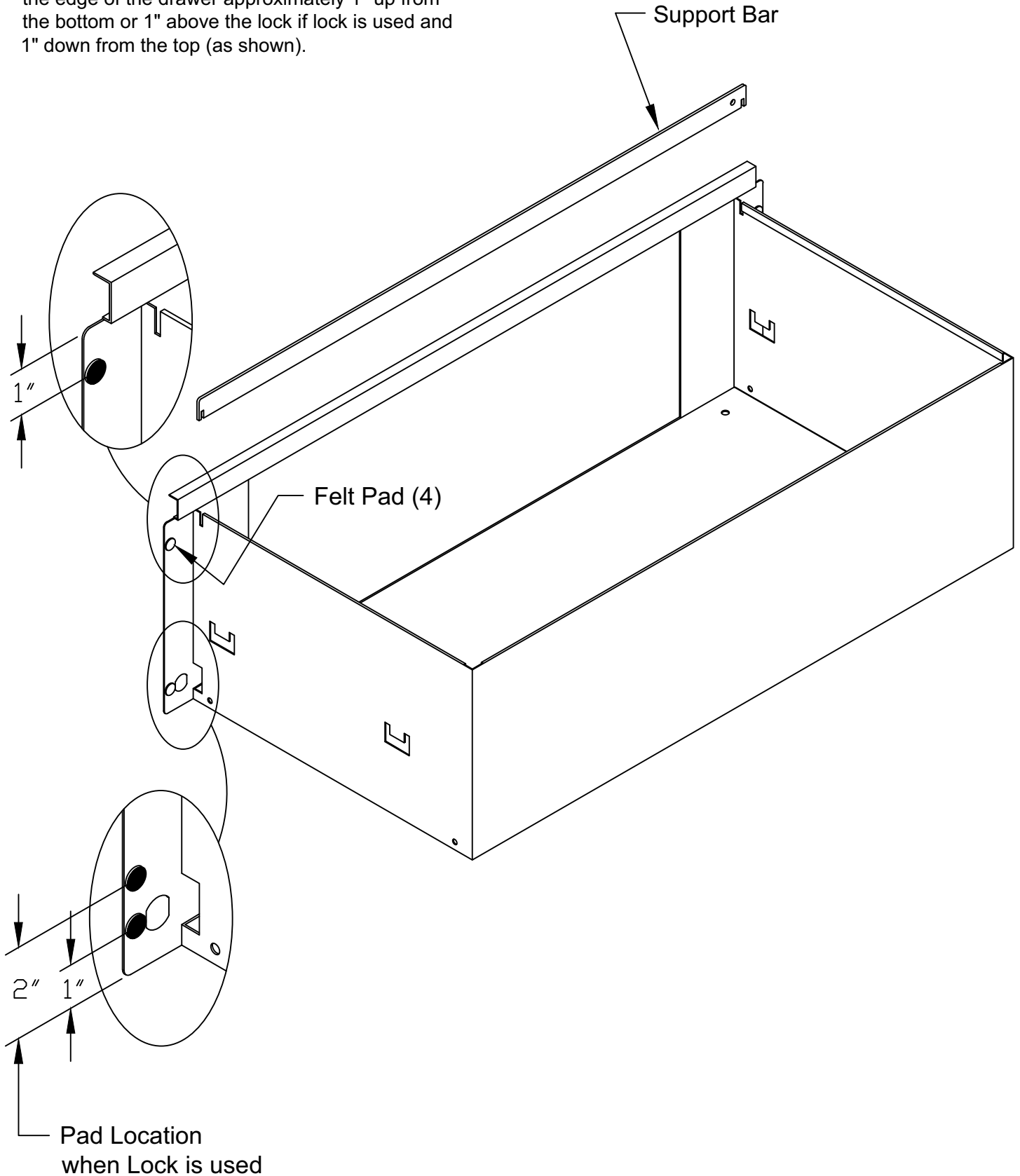

18" SHELVES: The four post units with drawers will use a shelf that has slots for the back stop and dividers arranged for both letter and legal media. The top canopy will not be slotted.

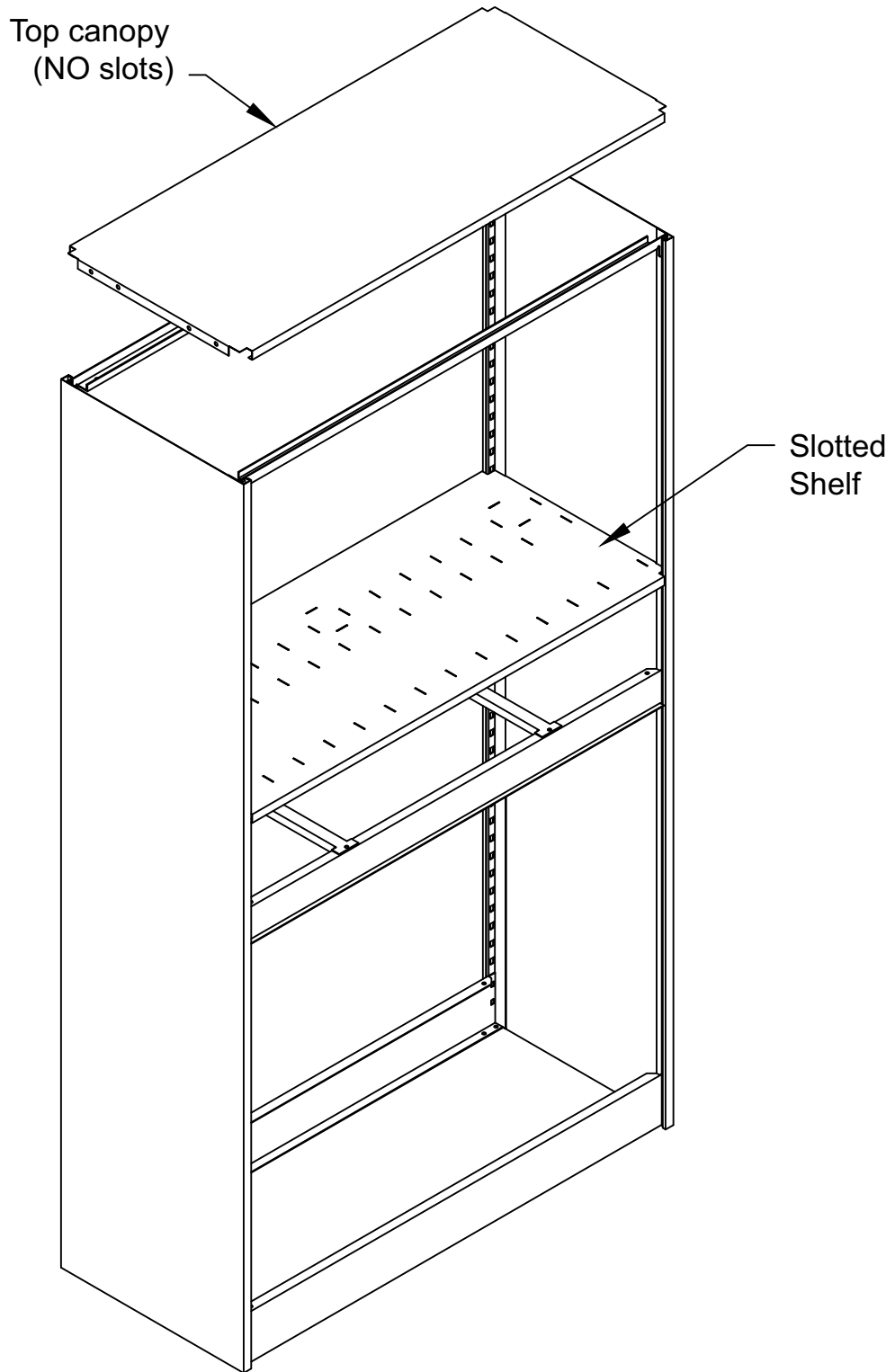

36" SHELVES: The four post units with drawers will use a shelf that has slots for the back stop and dividers arranged for both letter and legal media. The top canopy will not be slotted.

