

ASSEMBLY INSTRUCTIONS

FLIP-N-GO TABLES

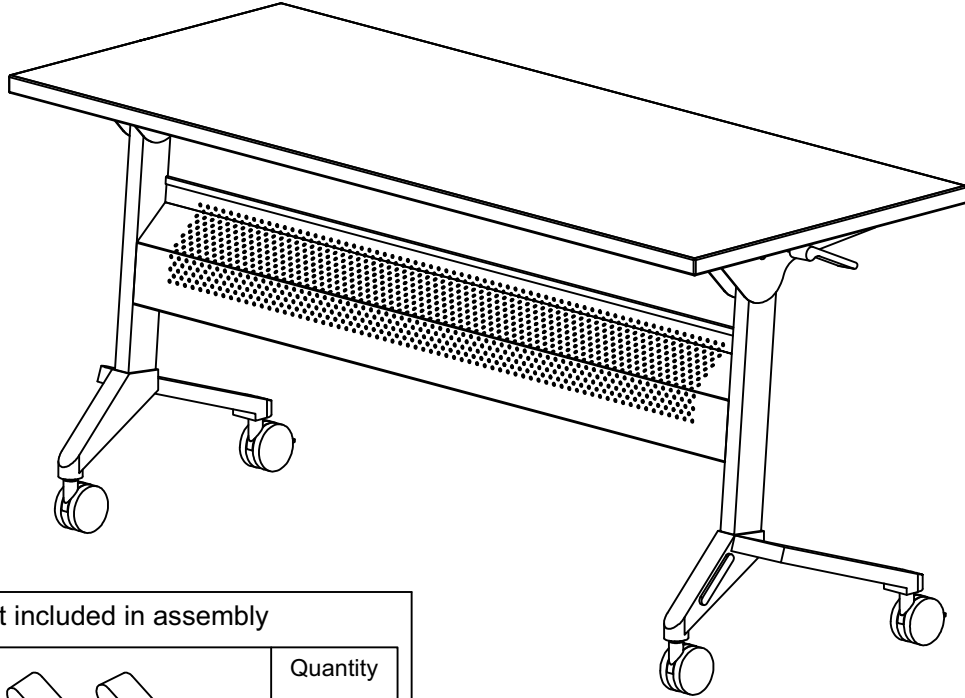
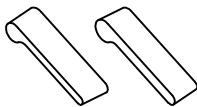
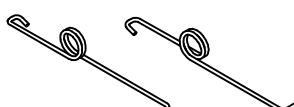
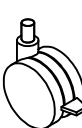
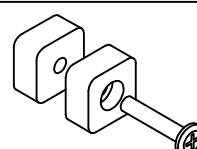
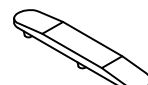

Replacement Parts not included in assembly

LF102*		Quantity 1
Handles (Pair) left & right		
LF103*		Quantity 1
Springs (Pair) left & right		
LF104*		Quantity 1
Caster (single)		
LF105*		Quantity 1
Table Bumpers (2) with Screw		
LF106*		Quantity 1
Foot Bumper (single)		

Replacement Parts not included in assembly

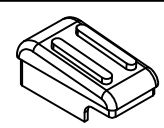
LF129*		Quantity 1
Frame Cap Top (Single)		

Leveling Tool upon Request.

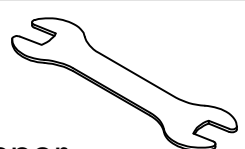
Q642*		Quantity 1
Wrench, Spanner		

PARTS LIST FLIP-N-GO TABLES

When ordering components, specific color and/or size information may be required.
Contact a Saeco Customer Service Representative. 1-888-971-6225



**Individual Items, Order by part number.*

*** Denotes Color Code*

~~Denotes Size

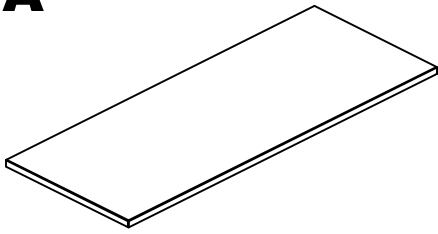
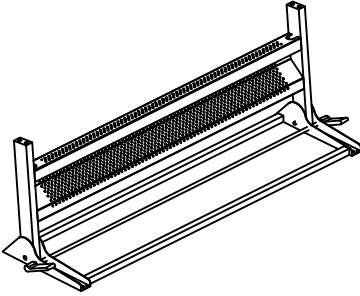
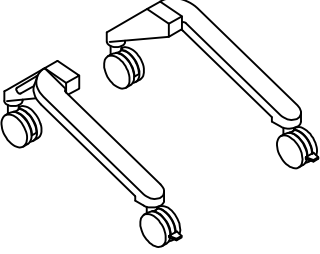
NOTE: Please count and inspect all pieces before disposing of any carton or packing materials.

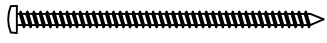
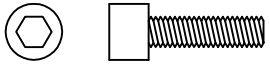
Reference Letter <div style="text-align: center; font-size: 2em; font-weight: bold;">A</div>  Part Number Top CALL ~~**	Quantity <div style="font-size: 2em; font-weight: bold;">1</div>
Reference Letter <div style="text-align: center; font-size: 2em; font-weight: bold;">B</div>  Frame CALL ~~ **	Quantity <div style="font-size: 2em; font-weight: bold;">1</div>
Reference Letter <div style="text-align: center; font-size: 2em; font-weight: bold;">C</div>  LF101** Feet (pair) with casters	Quantity <div style="font-size: 2em; font-weight: bold;">1</div>

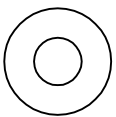
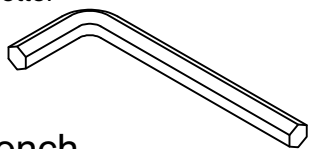
Part Number LF100* Hardware Bag			
Reference Letter <div style="text-align: center; font-size: 2em; font-weight: bold;">D</div>  Screw ST4 x 16mm	Quantity <div style="font-size: 2em; font-weight: bold;">8</div>	Extra <div style="font-size: 2em; font-weight: bold;">1</div>	
Reference Letter <div style="text-align: center; font-size: 2em; font-weight: bold;">E</div>  Screw ST4 x 40mm	Quantity <div style="font-size: 2em; font-weight: bold;">6</div>	Extra <div style="font-size: 2em; font-weight: bold;">1</div>	
Reference Letter <div style="text-align: center; font-size: 2em; font-weight: bold;">F</div>  Screw M10 x 30mm	Quantity <div style="font-size: 2em; font-weight: bold;">4</div>		
Reference Letter <div style="text-align: center; font-size: 2em; font-weight: bold;">G</div>  Lock Washer	Quantity <div style="font-size: 2em; font-weight: bold;">4</div>		
Reference Letter <div style="text-align: center; font-size: 2em; font-weight: bold;">H</div>  Washer	Quantity <div style="font-size: 2em; font-weight: bold;">4</div>		
Reference Letter <div style="text-align: center; font-size: 2em; font-weight: bold;">J</div>  Allen Wrench	Quantity <div style="font-size: 2em; font-weight: bold;">1</div>		

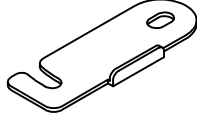
Part Number 10GA* Ganging Kit			
Reference Letter <div style="text-align: center; font-size: 2em; font-weight: bold;">K</div> Knob		Quantity <div style="font-size: 2em; font-weight: bold;">4</div>	Reference Letter <div style="text-align: center; font-size: 2em; font-weight: bold;">L</div> Bracket
		Quantity <div style="font-size: 2em; font-weight: bold;">2</div>	

1. Place Top (A) face down on a clean flat surface. Locate guide hole in top and place the Frame as shown in Fig. #1. Center the obround hole in the top mounting bracket of the Frame with the guide hole in the Top. See Fig. #2.

2. Attach Frame (B) onto Top using 8 Screws (D) for the mounting brackets & 6 Screws (E) for cross bars. See Fig. #1

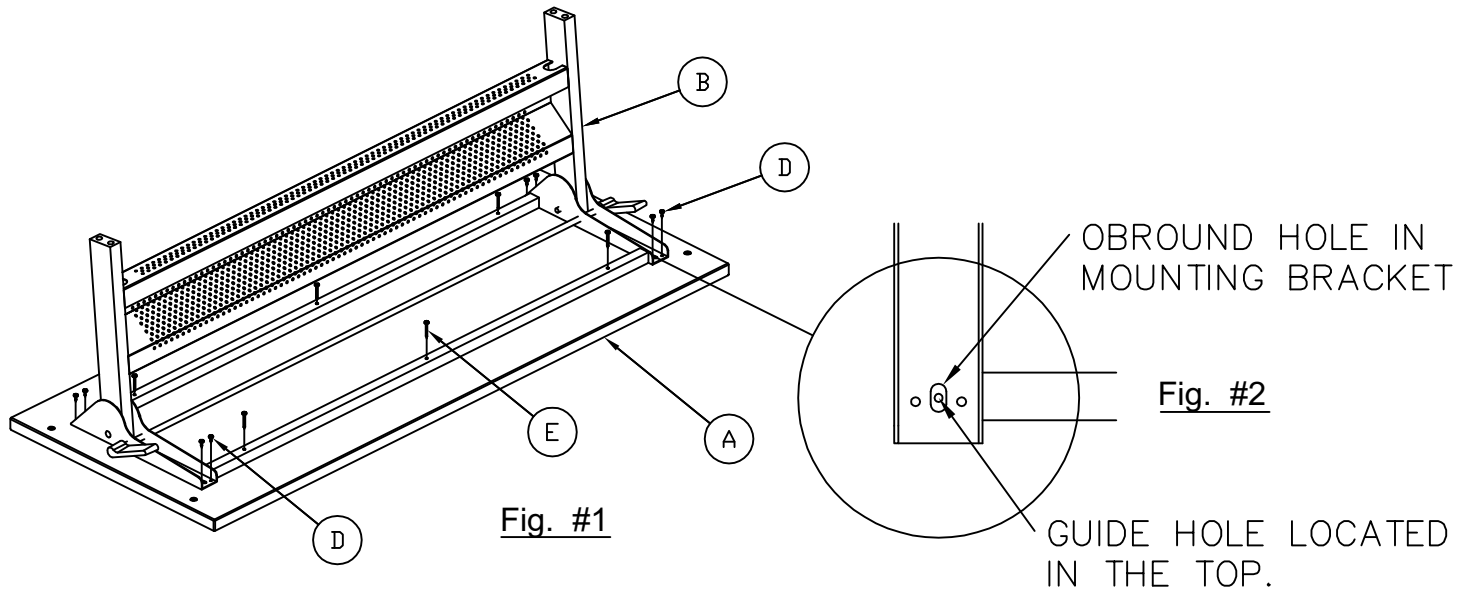

3. Attach Feet (C) to Frame (B) using 2 Screws (F), 2 Lock washers (G) & 2 Washers (H) per Leg as shown in Fig. #3. Be sure to pay attention to the "L" (Left) and the "R" (Right) on the bottom of the feet.

Tip: When tightening the leg, line up the leg with the side of the table.

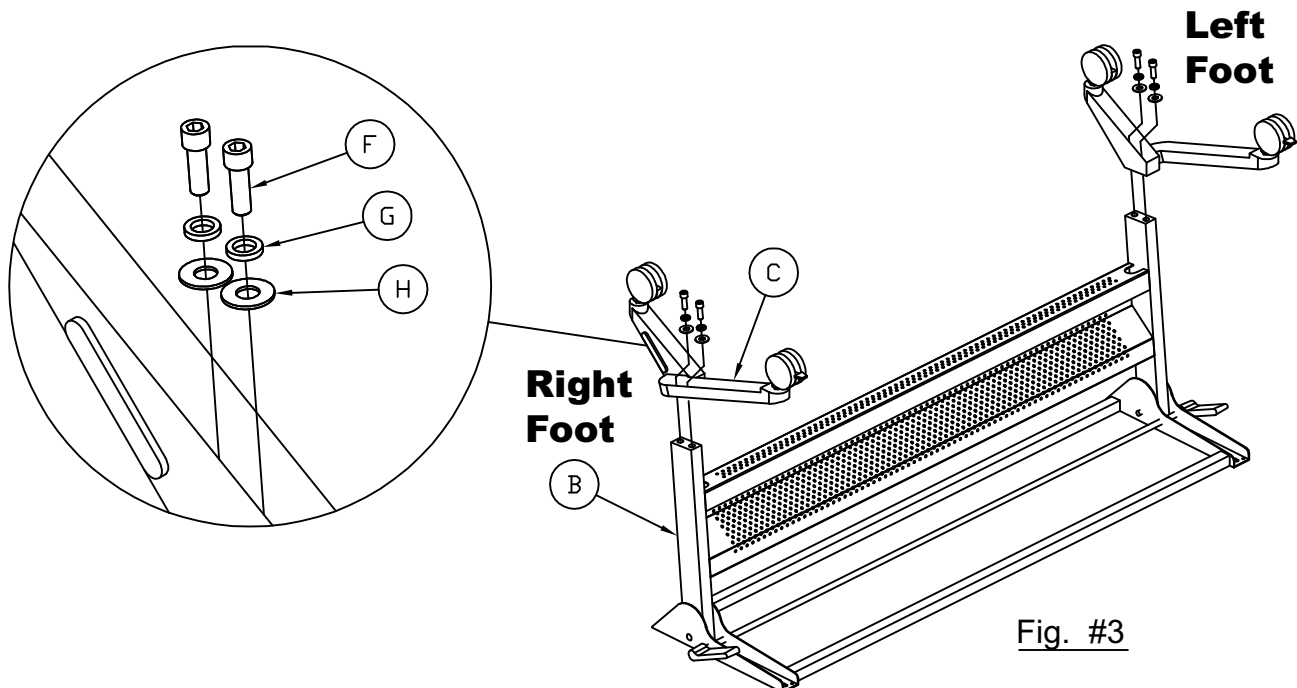

Transition Table Assembly Only (Conference vs. Stadium)

Note: Modesty Panel location has two options for assembly.

1.Begin Assembly by determining if the table will be used as Conference or Stadium position. See Fig. #4

2.Follow Instructions on page 3, Steps 1 - 3

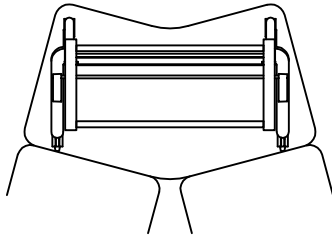

Conference position

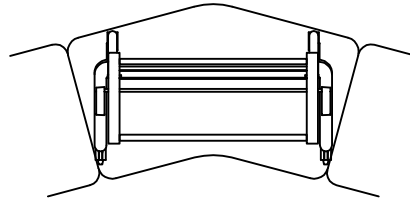

Stadium position

Fig. #4

FOLDING OPERATION

Flip top up.

Rotate handle towards top to release locking mechanism and rotate top up.

Flip top down.

Rotate handle towards top to release locking mechanism and rotate top down.

LIFT HANDLE
TOWARDS TOP

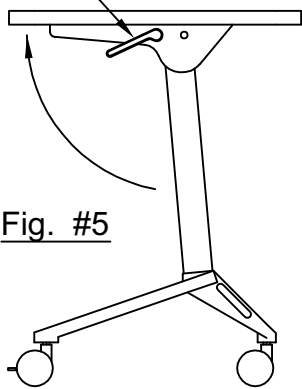

Fig. #5

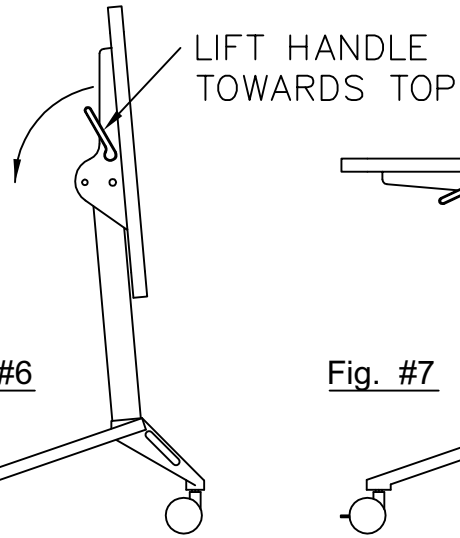

Fig. #6

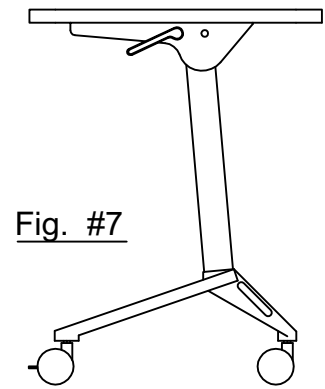

Fig. #7

NESTING OPERATION

Place tables as shown in Fig. #7 with one side nested. Rotate other side into nested position.

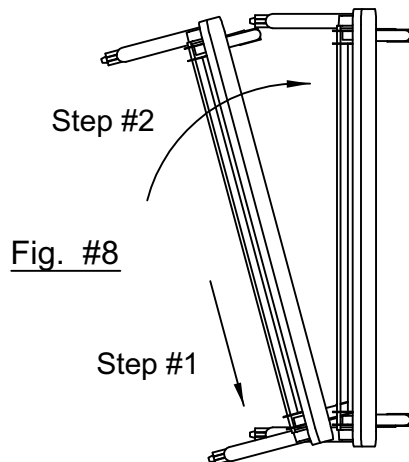

Fig. #8

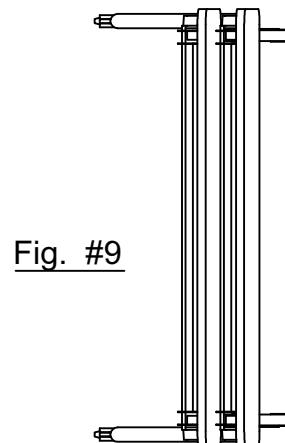

Fig. #9

5. Attach Ganging Brackets with tables in upright & approximate position. Insert Knobs (K) through the Ganging Brackets (L) into the metal inserts in the Top and tighten as shown in Fig #10 & #11. Ganging Brackets allow tables to be joined either side to side and/or back to back.

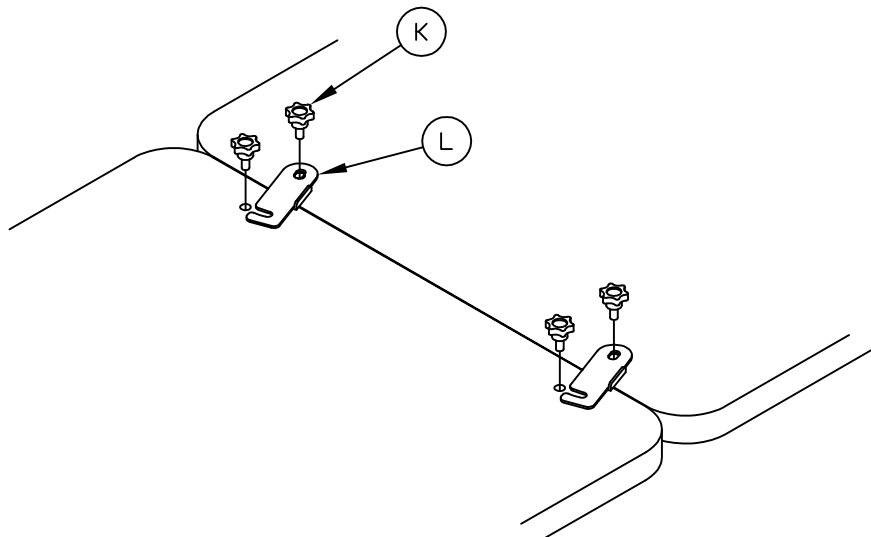

Fig. #10

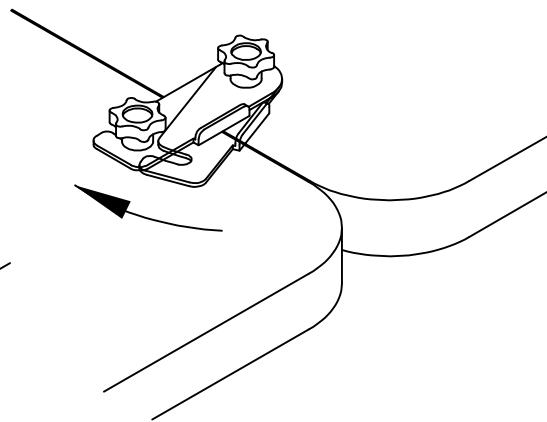

Fig. #11